

SECTION 43 BURN MIZER CREMATORS

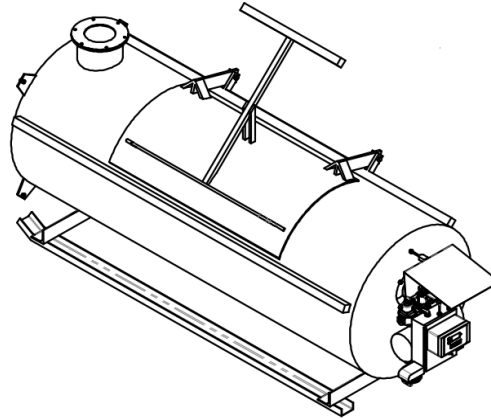

IN THIS CATALOG SECTION

PAGE NUMBER	CONTENTS
43-02	How To Order a Cremator & Determine Capacity Needed
43-03	Model 4820 Cremators
43-04	Model 4830 Cremators
43-05	Model 7230 Cremators
43-06	Model 8430 Cremators
43-07	Model 8436 Cremators
43-08	Model 9642 Cremators
43-09	Model 10852 Cremators
43-10	Model 12 - Model 20 Secondary Burners
43-11 thru 43-13	Cremator Tank Repairs

REPAIRS

SEE REPAIR LISTING & REFERENCE MATERIAL IN SEPARATE CATALOG



HOW TO ORDER A BURN MIZER CREMATOR

1. Determine cremator capacity needed (see below).
2. Select exact catalog number of cremator model needed depending on type of fuel and electric to be used and door size required.
3. If wanted, select optional Secondary Burner
4. Select Exhaust Stack, Manufacture's recommendations of 3' minimum length, not needed with Secondary Burner when exhaust not under cover.
5. If needed, order Optional Winched Door.
6. If wanted, select optional grate kit for cremator.

HOW TO DETERMINE CREMATOR CAPACITY NEEDED

- Info Needed:
- A. Total number of animals at site
 - B. Sell weight of individual animal
 - C. Number of days animals will be on site
 - D. Mortality Rate

Formula to determine daily cremator capacity needed:

$$A \times B \div C \times D = \text{Daily Capacity Required}$$

EXAMPLE: Poultry

3 broiler houses with 23,000 birds per house, 4.5 pounds per bird, on the farm for 44 days with 4% mortality:

Number on farm	69,000
Weight	x 4.5
	= 310,500
Number of days	÷ 44
	= 7057
Mortality	x .04
Pounds per day	282

Select Model 7230 Cremator with 400 pound capacity.

EXAMPLE: Swine

3 finishing houses with 1,100 pigs per house, 220 pounds per pig, 152 days on site, 3% mortality:

Number on farm	3,300
Weight	x 220
	= 726,000
Number of days	÷ 152
	= 4776
Mortality	x .03
Pounds per day	143

Select Model 7230 Cremator with 400 pound capacity. Be sure to select model with proper size door large enough for swine.

Capacities shown for cremators are based on practical usage. Actual capacity is affected by cremator size, animal size, use of grate, timely clean-out and other factors.

Note: All cremators with doors larger than 19" deep are shipped with winched loading doors. This includes some models of 8430, 8436, 9642 & 10852.

MODEL 4820 BURN MIZER CREMATORS
4' Long x 20" Diameter - NOT Block Lined
3/8" - 1/2" Steel Construction Reinforced With 1" x 2" Solid Bar
6 Hour Mechanical Timer

MODEL 4820 CREMATORS - NO STACK

CATALOG NUMBER	CAPACITY			FUEL TYPE	NO. OF DOORS DOOR OPENING	ELECTRIC		SHIPPING WEIGHT		LIST PRICE
	FT ³	LBS.	KG.			Volts	Hertz	LBS.	KG.	
475400	8	100	45	Oil	1 -24" x 12"	120v	60 HZ	563.0	255.4	
475401	8	100	45	LP	1 -24" x 12"	120v	60 HZ	563.0	255.4	
475402	8	100	45	NG	1 -24" x 12"	120v	60 HZ	563.0	255.4	
475406	8	100	45	Oil	1 -24" x 12"	230v	60 HZ	563.0	255.4	
475407	8	100	45	LP	1 -24" x 12"	230v	60 HZ	563.0	255.4	
475408	8	100	45	NG	1 -24" x 12"	230v	60 HZ	563.0	255.4	
475403	8	100	45	Oil	1 -24" x 12"	230v	50 HZ	563.0	255.4	
475404	8	100	45	LP	1 -24" x 12"	230v	50 HZ	563.0	255.4	
475405	8	100	45	NG	1 -24" x 12"	230v	50 HZ	563.0	255.4	

OPTIONS - MODEL 4820 CREMATORS

	DESCRIPTION & ORDERING INSTRUCTIONS	SHIPPING WEIGHT		LIST PRICE
		LBS.	KG.	
475065F-01	6" x 1' Stack Pipe with Welded Flange Ring	21.0	9.5	
475065F-02	6" x 2' Stack Pipe with Welded Flange Ring	40.0	18.1	
475065F-03	6" x 3' Stack Pipe with Welded Flange Ring	59.0	26.8	
475065F-04	6" x 4' Stack Pipe with Welded Flange Ring	78.0	35.4	
475065F-05	6" x 5' Stack Pipe with Welded Flange Ring	97.0	44.0	
475065F-06	6" x 6' Stack Pipe with Welded Flange Ring	116.0	52.6	
475065F-07	6" x 7' Stack Pipe with Welded Flange Ring	135.0	61.2	
475065F-08	6" x 8' Stack Pipe with Welded Flange Ring	154.0	69.9	

NOTE: Optional ash door & grate kit are not available on Model 4820 Cremators.

MODEL 4830 BURN MIZER CREMATORS

4' Long x 30" Diameter - Block Lined
 3/8" - 1/2" Steel Construction Reinforced With 1" x 2" Solid Bar
 12 Hour Solid State Timer & Heat Control, Ash Removal Door

MODEL 4830 CREMATORS - NO STACK

CATALOG NUMBER	CAPACITY			FUEL TYPE	NO. OF DOORS DOOR OPENING	ELECTRIC		SHIPPING WEIGHT		LIST PRICE
	FT ³	LBS.	KG.			Volts	Hertz	LBS.	KG.	
475409	13	200	90	Oil	1 - 28" X 18"	120v		1,400.0		
475410	13	200	90	LP	1 - 28" X 18"	120v		1,400.0		
475411	13	200	90	NG	1 - 28" X 18"	120v		1,400.0		
475415	13	200	90	Oil	1 - 28" X 18"	230v		1,400.0		
475416	13	200	90	LP	1 - 28" X 18"	230v		1,400.0		
475417	13	200	90	NG	1 - 28" X 18"	230v		1,400.0		
475412	13	200	90	Oil	1 - 28" X 18"	230v	50 HZ	1,400.0		
475413	13	200	90	LP	1 - 28" X 18"	230v	50 HZ	1,400.0		
475414	13	200	90	NG	1 - 28" X 18"	230v	50 HZ	1,400.0		

OPTIONS - MODEL 4830 CREMATORS

CATALOG NUMBER	ITEM DESCRIPTION	SHIPPING WEIGHT		LIST PRICE
		LBS.	KG.	
475090	Optional Grate Kit for Model 4830 Cremators	160.0		
475070	Optional Winched Loading Door If this option is chosen for a two door model cremator, the two doors will be automatically be changed to a single door.	95.0		
4753812	Optional Winch Load System	200.0		
475065F-01	6" x 1' Stack Pipe with Welded Flange Ring	21.0		
475065F-02	6" x 2' Stack Pipe with Welded Flange Ring	40.0		
475065F-03	6" x 3' Stack Pipe with Welded Flange Ring	59.0		
475065F-04	6" x 4' Stack Pipe with Welded Flange Ring	78.0		
475065F-05	6" x 5' Stack Pipe with Welded Flange Ring	97.0		
475065F-06	6" x 6' Stack Pipe with Welded Flange Ring	116.0		
475065F-07	6" x 7' Stack Pipe with Welded Flange Ring	135.0	61.2	
475065F-08	6" x 8' Stack Pipe with Welded Flange Ring	154.0	69.9	



MODEL 7230 BURN MIZER CREMATORS

6' Long x 30" Diameter - Block Lined
 3/8" - 1/2" Steel Construction Reinforced With 1" x 2" Solid Bar
 12 Hour Solid State Timer & Heater Control, Ash Removal Door

MODEL 7230 CREMATORS - NO STACK

CATALOG NUMBER	CAPACITY			FUEL TYPE	NO. OF DOORS DOOR OPENING	ELECTRIC		SHIPPING WEIGHT		LIST PRICE
	FT ³	LBS.	KG.			Volts	Hertz	LBS.	KG.	
475418	20	400	181	Oil	1 - 42" x 18"	120v	60 HZ	1,650.0	748.4	
475419	20	400	181	LP	1 - 42" x 18"	120v	60 HZ	1,650.0	748.4	
475420	20	400	181	NG	1 - 42" x 18"	120v	60 HZ	1,650.0	748.4	
475424	20	400	181	Oil	1 - 42" x 18"	230v	60 HZ	1,650.0	748.4	
475425	20	400	181	LP	1 - 42" x 18"	230v	60 HZ	1,650.0	748.4	
475426	20	400	181	NG	1 - 42" x 18"	230v	60 HZ	1,650.0	748.4	
475421	20	400	181	Oil	1 - 42" x 18"	230v	50 HZ	1,650.0	748.4	
475422	20	400	181	LP	1 - 42" x 18"	230v	50 HZ	1,650.0	748.4	
475423	20	400	181	NG	1 - 42" x 18"	230v	50 HZ	1,650.0	748.4	

OPTIONS - MODEL 7230 CREMATORS

CATALOG NUMBER	ITEM DESCRIPTION	SHIPPING WEIGHT		LIST PRICE
		LBS.	KG.	
475091	Optional Grate Kit for Model 7230/8430 Cremators	216.0	113.4	
475070	Optional Winched Loading Door If this option is chosen for a two door model cremator, the two doors will be automatically be changed to a single door.	95.0	43.1	
4753812	Optional Winch Load System	200.0	90.7	
475065F-01	6" x 1' Stack Pipe with Welded Flange Ring	21.0	9.5	
475065F-02	6" x 2' Stack Pipe with Welded Flange Ring	40.0	18.1	
475065F-03	6" x 3' Stack Pipe with Welded Flange Ring	59.0	26.8	
475065F-04	6" x 4' Stack Pipe with Welded Flange Ring	78.0	35.4	
475065F-05	6" x 5' Stack Pipe with Welded Flange Ring	97.0	44.0	
475065F-06	6" x 6' Stack Pipe with Welded Flange Ring	116.0	52.6	
475065F-07	6" x 7' Stack Pipe with Welded Flange Ring	135.0	61.2	
475065F-08	6" x 8' Stack Pipe with Welded Flange Ring	154.0	69.9	

MODEL 8430 BURN MIZER CREMATORS

7' Long x 30" Diameter - Block Lined; 3/8" - 1/2" Steel Construction Reinforced With 1" x 2" Solid Bar
 12 Hour Solid State Timer & Heater Control, Ash Removal Door

MODEL 8430 CREMATORS - NO STACK

CATALOG NUMBER	CAPACITY			FUEL TYPE	NO. OF DOORS DOOR SIZE	ELECTRIC		SHIPPING WEIGHT		LIST PRICE
	FT ³	LBS.	KG.			Volts	Hertz	LBS.	KG.	
475427	25	500	226	Oil	1 - 42" x 18"	120v	60 HZ	1,925.0	873.2	
475428	25	500	226	LP	1 - 42" x 18"	120v	60 HZ	1,925.0	873.2	
475429	25	500	226	NG	1 - 42" x 18"	120v	60 HZ	1,925.0	873.2	
475433	25	500	226	Oil	1 - 42" x 18"	230v	60 HZ	1,925.0	873.2	
475434	25	500	226	LP	1 - 42" x 18"	230v	60 HZ	1,925.0	873.2	
475435	25	500	226	NG	1 - 42" x 18"	230v	60 HZ	1,925.0	873.2	
475430	25	500	226	Oil	1 - 42" x 18"	230v	50 HZ	1,925.0	873.2	
475431	25	500	226	LP	1 - 42" x 18"	230v	50 HZ	1,925.0	873.2	
475432	25	500	226	NG	1 - 42" x 18"	230v	50 HZ	1,925.0	873.2	

MODEL 8430 CREMATORS - NO STACK (with Raised Burner for Hatchery Waste)

475508	25	500	226	LP	1 - 42" x 18"	230v	50 HZ	1,925.0	873.2	
--------	----	-----	-----	----	---------------	------	-------	---------	-------	--

OPTIONS - MODEL 8430 CREMATORS

CATALOG NUMBER	ITEM DESCRIPTION	SHIPPING WEIGHT		LIST PRICE
		LBS.	KG.	
475091	Optional Grate Kit for Model 8430 Cremators	216.0	98.0	
475070	Optional Winched Loading Door If this option is chosen for a two door model cremator, the two doors will be automatically be changed to a single door.	95.0	43.1	
4753812	Optional Winch Load System	200.0	90.7	
475065F-01	6" x 1' Stack Pipe with Welded Flange Ring	21.0	9.5	
475065F-02	6" x 2' Stack Pipe with Welded Flange Ring	40.0	18.1	
475065F-03	6" x 3' Stack Pipe with Welded Flange Ring	59.0	26.8	
475065F-04	6" x 4' Stack Pipe with Welded Flange Ring	78.0	35.4	
475065F-05	6" x 5' Stack Pipe with Welded Flange Ring	97.0	44.0	
475065F-06	6" x 6' Stack Pipe with Welded Flange Ring	116.0	52.6	
475065F-07	6" x 7' Stack Pipe with Welded Flange Ring	135.0	61.2	
475065F-08	6" x 8' Stack Pipe with Welded Flange Ring	154.0	69.9	



MODEL 8436 BURN MIZER CREMATORS

7' Long x 36" Diameter - Block Lined; 3/8" - 1/2" Steel Construction Reinforced With 1" x 2" Solid Bar
 12 Hour Solid State Timer & Heat Control, Ash Removal Door

Note: All cremators with doors larger than 19" deep are shipped with winched loading doors. This includes some 8436 models .

MODEL 8436 CREMATORS - NO STACK

CATALOG NUMBER	CAPACITY			FUEL TYPE	NO. OF DOORS DOOR OPENING	ELECTRIC		SHIPPING WEIGHT		LIST PRICE
	FT ³	LBS.	KG.			Volts	Hertz	LBS.	KG.	
475436	35	600	272	Oil	1 - 36" x 18"	120v	60 HZ	2,550.0	1,156.7	
475437	35	600	272	LP	1 - 36" x 18"	120v	60 HZ	2,550.0	1,156.7	
475438	35	600	272	NG	1 - 36" x 18"	120v	60 HZ	2,550.0	1,156.7	
475439	35	600	272	Oil	1 - 42" x 18"	120v	60 HZ	2,550.0	1,156.7	
475440	35	600	272	LP	1 - 42" x 18"	120v	60 HZ	2,550.0	1,156.7	
475441	35	600	272	NG	1 - 42" x 18"	120v	60 HZ	2,550.0	1,156.7	
475442	35	600	272	Oil	1 - 54" x 23" Winch	120v	60 HZ	2,550.0	1,156.7	
475443	35	600	272	LP	1 - 54" x 23" Winch	120v	60 HZ	2,550.0	1,156.7	
475444	35	600	272	NG	1 - 54" x 23" Winch	120v	60 HZ	2,550.0	1,156.7	
475454	35	600	272	Oil	1 - 36" x 18"	230v	60 HZ	2,550.0	1,156.7	
475455	35	600	272	LP	1 - 36" x 18"	230v	60 HZ	2,550.0	1,156.7	
475456	35	600	272	NG	1 - 36" x 18"	230v	60 HZ	2,550.0	1,156.7	
475457	35	600	272	Oil	1 - 42" x 18"	230v	60 HZ	2,550.0	1,156.7	
475458	35	600	272	LP	1 - 42" x 18"	230v	60 HZ	2,550.0	1,156.7	
475459	35	600	272	NG	1 - 42" x 18"	230v	60 HZ	2,550.0	1,156.7	
475460	35	600	272	Oil	1 - 54" x 23" Winch	230v	60 HZ	2,550.0	1,156.7	
475461	35	600	272	LP	1 - 54" x 23" Winch	230v	60 HZ	2,550.0	1,156.7	
475462	35	600	272	NG	1 - 54" x 23" Winch	230v	60 HZ	2,550.0	1,156.7	
475445	35	600	272	Oil	1 - 36" x 18"	230v	50 HZ	2,550.0	1,156.7	
475446	35	600	272	LP	1 - 36" x 18"	230v	50 HZ	2,550.0	1,156.7	
475447	35	600	272	NG	1 - 36" x 18"	230v	50 HZ	2,550.0	1,156.7	
475448	35	600	272	Oil	1 - 42" x 18"	230v	50 HZ	2,550.0	1,156.7	
475449	35	600	272	LP	1 - 42" x 18"	230v	50 HZ	2,550.0	1,156.7	
475450	35	600	272	NG	1 - 42" x 18"	230v	50 HZ	2,550.0	1,156.7	
475451	35	600	272	Oil	1 - 54" x 23" Winch	230v	50 HZ	2,550.0	1,156.7	
475452	35	600	272	LP	1 - 54" x 23" Winch	230v	50 HZ	2,550.0	1,156.7	
475453	35	600	272	NG	1 - 54" x 23" Winch	230v	50 HZ	2,550.0	1,156.7	

OPTIONS - MODEL 8436 CREMATORS

CATALOG NUMBER	ITEM DESCRIPTION	SHIPPING WEIGHT		LIST PRICE
		LBS.	KG.	
475092	Optional Grate Kit for Model 8436 Cremators	268.0	121.6	
475070	Optional Winched Loading Door	95.0	43.1	
4753812	Optional Winch Load System	200.0	90.7	
475065F-01	6" x 1' Stack Pipe with Welded Flange Ring	21.0	9.5	
475065F-02	6" x 2' Stack Pipe with Welded Flange Ring	40.0	18.1	
475065F-03	6" x 3' Stack Pipe with Welded Flange Ring	59.0	26.8	
475065F-04	6" x 4' Stack Pipe with Welded Flange Ring	78.0	35.4	
475065F-05	6" x 5' Stack Pipe with Welded Flange Ring	97.0	44.0	
475065F-06	6" x 6' Stack Pipe with Welded Flange Ring	116.0	52.6	
475065F-07	6" x 7' Stack Pipe with Welded Flange Ring	135.0	61.2	
475065F-08	6" x 8' Stack Pipe with Welded Flange Ring	154.0	69.9	



MODEL 9642 BURN MIZER CREMATORS

8' Long x 42" Diameter - Block Lined; 3/8" - 1/2" Steel Construction Reinforced With 1" x 2" Solid Bar
 Winched Door Included As Standard on All Model 9642 Units
 12 Hour Solid State Timer & Heat Control, Ash Removal Door

MODEL 9642 CREMATORS - NO STACK

CATALOG NUMBER	CAPACITY			FUEL TYPE	NO. OF DOORS DOOR OPENING	ELECTRIC		SHIPPING WEIGHT		LIST PRICE
	FT ³	LBS.	KG.			Volts	Hertz	LBS.	KG.	
475463	58	1200	544	Oil	1 - 66" X 31" Winch	120v	60 HZ	3,450.0	1,564.9	
475464	58	1200	544	LP	1 - 66" X 31" Winch	120v	60 HZ	3,450.0	1,564.9	
475465	58	1200	544	NG	1 - 66" X 31" Winch	120v	60 HZ	3,450.0	1,564.9	
475469	58	1200	544	Oil	1 - 66" X 31" Winch	230v	60 HZ	3,450.0	1,564.9	
475470	58	1200	544	LP	1 - 66" X 31" Winch	230v	60 HZ	3,450.0	1,564.9	
475471	58	1200	544	NG	1 - 66" X 31" Winch	230v	60 HZ	3,450.0	1,564.9	
475466	58	1200	544	Oil	1 - 66" X 31" Winch	230v	50 HZ	3,450.0	1,564.9	
475467	58	1200	544	LP	1 - 66" X 31" Winch	230v	50 HZ	3,450.0	1,564.9	
475468	58	1200	544	NG	1 - 66" X 31" Winch	230v	50 HZ	3,450.0	1,564.9	

OPTIONS - MODEL 9642 CREMATORS

CATALOG NUMBER	ITEM DESCRIPTION	SHIPPING WEIGHT		LIST PRICE
		LBS.	KG.	
475093	Optional Grate Kit for Model 9642 Cremators	336.0	152.4	
4753812	Optional Winch Load System	200.0	90.7	
475065F-01	6" x 1' Stack Pipe with Welded Flange Ring	21.0	9.5	
475065F-02	6" x 2' Stack Pipe with Welded Flange Ring	40.0	18.1	
475065F-03	6" x 3' Stack Pipe with Welded Flange Ring	59.0	26.8	
475065F-04	6" x 4' Stack Pipe with Welded Flange Ring	78.0	35.4	
475065F-05	6" x 5' Stack Pipe with Welded Flange Ring	97.0	44.0	
475065F-06	6" x 6' Stack Pipe with Welded Flange Ring	116.0	52.6	
475065F-07	6" x 7' Stack Pipe with Welded Flange Ring	135.0	61.2	
475065F-08	6" x 8' Stack Pipe with Welded Flange Ring	154.0	69.9	

WINCHED DOOR IS STANDARD ON ALL MODEL 9642 CREMATORS



MODEL 10852 BURN MIZER CREMATORS

9' Long x 52" Diameter - Block Lined
 3/8" - 1/2" Steel Construction Reinforced With 1" x 2" Solid Bar
Winched Door Included As Standard on All Model 10852 Units
 12 Hour Solid State Timer & Heat Control, Ash Removal Door

MODEL 10852 CREMATORS - NO STACK

CATALOG NUMBER	CAPACITY			FUEL TYPE	NO. OF DOORS DOOR OPENING	ELECTRIC		SHIPPING WEIGHT		LIST PRICE
	FT ³	LBS.	KG.			Volts	Hertz	LBS.	KG.	
475472	106	2000	907	Oil	1 - 77" X 45" Winch	120v	60 HZ	5,645.0	2,560.5	
475473	106	2000	907	LP	1 - 77" X 45" Winch	120v	60 HZ	5,645.0	2,560.5	
475474	106	2000	907	NG	1 - 77" X 45" Winch	120v	60 HZ	5,645.0	2,560.5	
475478	106	2000	907	Oil	1 - 77" X 45" Winch	230v	60 HZ	5,645.0	2,560.5	
475479	106	2000	907	LP	1 - 77" X 45" Winch	230v	60 HZ	5,645.0	2,560.5	
475480	106	2000	907	NG	1 - 77" X 45" Winch	230v	60 HZ	5,645.0	2,560.5	
475475	106	2000	907	Oil	1 - 77" X 45" Winch	230v	50 HZ	5,645.0	2,560.5	
475476	106	2000	907	LP	1 - 77" X 45" Winch	230v	50 HZ	4,826.0	2,189.0	
475477	106	2000	907	NG	1 - 77" X 45" Winch	230v	50 HZ	5,645.0	2,560.5	

OPTIONS - MODEL 10852 CREMATORS

CATALOG NUMBER	ITEM DESCRIPTION	SHIPPING WEIGHT		LIST PRICE
		LBS.	KG.	
475095	Optional Grate Kit for Model 10852 Cremators	423.0	191.9	
4753812	Optional Winch Load System	200.0	90.7	
475066F-01	8" x 1' Stack Pipe with Welded Flange Ring	31.0	14.1	
475066F-02	8" x 2' Stack Pipe with Welded Flange Ring	60.0	27.2	
475066F-03	8" x 3' Stack Pipe with Welded Flange Ring	89.0	40.4	
475066F-04	8" x 4' Stack Pipe with Welded Flange Ring	118.0	53.5	
475066F-05	8" x 5' Stack Pipe with Welded Flange Ring	147.0	66.7	
475066F-06	8" x 6' Stack Pipe with Welded Flange Ring	176.0	79.8	
475066F-07	8" x 7' Stack Pipe with Welded Flange Ring	205.0	93.0	
475066F-08	8" x 8' Stack Pipe with Welded Flange Ring	234.0	106.1	

WINCHED DOOR IS STANDARD ON ALL MODEL 10852 CREMATORS

MODEL 20 BURN MIZER SECONDARY BURNERS

Model 20: 48" Long x 20" Diameter
 1/4" Steel Construction
 6 Hour Mechanical Timer

Highly recommended to order (1) 475521 Shipping Stand per Secondary Burner

MODEL 20 SECONDARY BURNERS (EPA approved)

CATALOG NUMBER	STACK		FUEL TYPE	ELECTRIC TYPE		SHIPPING WEIGHT		LIST PRICE
	IN	OUT		Volts	Hertz	LBS.	KG.	
475490	6"	8"	Oil	120v	60 HZ	145.0	65.8	
475491	6"	8"	LP	120v	60 HZ	635.0	288.0	
475492	6"	8"	NG	120v	60 HZ	635.0	288.0	
475496	0	8"	Oil	230v	60 HZ	635.0	288.0	
475497	6"	8"	LP	230v	60 HZ	750.0	340.2	
475498	6"	8"	NG	230v	60 HZ	635.0	288.0	
475493	6"	8"	Oil	230v	50 HZ	635.0	288.0	
475494	6"	8"	LP	230v	50 HZ	635.0	288.0	
475495	6"	8"	NG	230v	50 HZ	635.0	288.0	
475521	Shipping Frame for Secondary Burner					60.0	27.2	

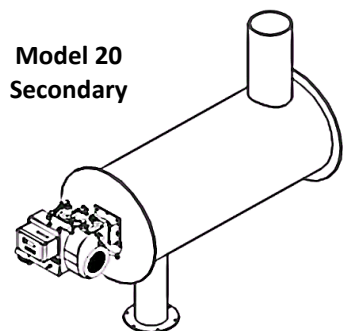

Model 20
Secondary

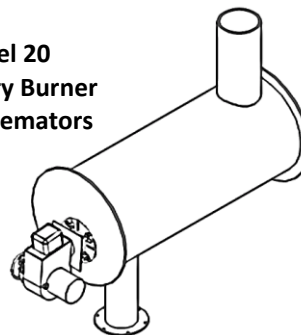

Model 20
Secondary Burner
10852 Cremators

MODEL 20 SECONDARY BURNERS for 10852 CREMATORS (EPA approved)

CATALOG NUMBER	STACK		FUEL TYPE	ELECTRIC TYPE		SHIPPING WEIGHT		LIST PRICE
	IN	OUT		Volts	Hertz	LBS.	KG.	
475499	8"	10"	Oil	120v	60 HZ	650.0	294.8	
475500	8"	10"	LP	120v	60 HZ	650.0	294.8	
475501	8"	10"	NG	120v	60 HZ	650.0	294.8	
475505	8"	10"	Oil	230v	60 HZ	650.0	294.8	
475506	8"	10"	LP	230v	60 HZ	650.0	294.8	
475507	8"	10"	NG	230v	60 HZ	650.0	294.8	
475502	8"	10"	Oil	230v	50 HZ	650.0	294.8	
475503	8"	10"	LP	230v	50 HZ	693.0	314.3	
475504	8"	10"	NG	230v	50 HZ	650.0	294.8	

BURN MIZER CREMATOR TANK REPAIRS

BLOCK LINER REPLACEMENT KITS

CATALOG NUMBER	ITEM DESCRIPTION	FOR MODEL	SHIPPING WEIGHT		LIST PRICE
			LBS.	KG.	
475175	Replacement Block Liner Kit	4830	420.0	190.5	
475176	Replacement Block Liner Kit	7230	580.0	263.1	
475177	Replacement Block Liner Kit	8436	620.0	281.2	
475178	Replacement Block Liner Kit	9642	925.0	419.6	
475174	Replacement Block Liner Kit	10852	925.0	419.6	

Kits include liner blocks, mortar & door insulation repair items (insulation, straps, & hardware).

REPLACEMENT LINER BLOCK ONLY

CATALOG NUMBER	ITEM DESCRIPTION	FOR MODEL	SHIPPING WEIGHT		LIST PRICE
			LBS.	KG.	
475180	Repair Block Only - 30" Diameters	4830 - 7230 - 8430	10.0	4.5	
475181	Repair Block Only - 36" Diameters	8436	13.5	6.1	
475182	Repair Block Only - 42" Diameter	9642	20.0	9.1	
475183	Repair Block Only - 52" Diameter	10852	20.0	9.1	
4753510	Refractory Mortar - 15 lb. Pail		15.0	6.8	
4753511	Refractory Mortar - 55 lb. Pail		0.0	0.0	

REPAIR DOORS ONLY (NO INSULATION, STRAPS, ANGLES, OR HARDWARE)

CATALOG NUMBER	ITEM DESCRIPTION	FOR MODEL	SHIPPING WEIGHT		LIST PRICE
			LBS.	KG.	
475220	Repair Door Only - 1 Door - 28" x 19"	4830	24.0	10.9	
475221	Repair Door Only - 1 Door - 36" x 19"	8436	24.0	10.9	
475222	Repair Door Only - 1 Door - 42" x 19"	7230 - 8430 - 8436	24.0	10.9	
475225	Repair Door Only - 1 Door - 52" x 22"	8436	24.0	10.9	
475227	Repair Door Only - 1 Door - 66" x 33"	9642	24.0	10.9	
475228	Repair Door Only - 1 Door - 78" x 51"	10852	24.0	10.9	

BURN MIZER CREMATOR TANK REPAIRS

DOOR INSULATION REPAIR KITS

CATALOG NUMBER	ITEM DESCRIPTION	FOR MODEL	SHIPPING WEIGHT		LIST PRICE
			LBS.	KG.	
475150	Door Insulation Repair Kit for Door - 28" x 19"	4830	24.0	10.9	
475151	Door Insulation Repair Kit for Door - 36" x 19"	8436	25.0	11.3	
475152	Door Insulation Repair Kit for Door - 42" x 19"	7230 - 8430 - 8436	25.0	11.3	
475155	Door Insulation Repair Kit for Door - 52" x 22"	8436	35.0	15.9	
475156	Door Insulation Repair Kit for Door - 66" x 33"	9642	68.0	30.8	
475157	Door Insulation Repair Kit for Door - 78" x 51"	10852	45.0	20.4	

Kits include repair insulation, straps, door angles, and hardware for installation.

REPAIR INSULATION ONLY FOR DOORS

CATALOG NUMBER	ITEM DESCRIPTION	FOR MODEL	SHIPPING WEIGHT		LIST PRICE
			LBS.	KG.	
475160	Repair Insulation Only for 1 Door - 28" x 19"	4830	0.0	0.0	
475161	Repair Insulation Only for 1 Door - 36" x 19"	8436	0.0	0.0	
475162	Repair Insulation Only for 1 Door - 42" x 19"	7230 - 8430 - 8436	0.0	0.0	
475165	Repair Insulation Only for 1 Door - 52" x 22"	8436	0.0	0.0	
475166	Repair Insulation Only for 1 Door - 66" x 33"	9642	0.0	0.0	
475167	Repair Insulation Only for 1 Door - 78" x 51"	10852	0.0	0.0	
475170	Repair Insulation - Full Roll - 34" Wide x 25' Len. - (70.8 ft ² - 6.58 m ²)		0.0	0.0	
475171	Repair Insulation - Full Roll - 36" Wide x 25' Len. - (75 ft ² - 6.97 m ²)		0.0	0.0	
475172	Repair Insulation - Full Roll - 48" Wide x 25' Len. - (100 ft ² - 9.29 m ²)		0.0	0.0	

INSULATION HARDWARE ONLY

CATALOG NUMBER	ITEM DESCRIPTION	SHIPPING WEIGHT		LIST PRICE
		LBS.	KG.	
475145	5" x 16" Strap for 1 Door Insulation (2 bolts & nuts req'd) Used on all 1 Door Cremators EXCEPT Models 7230 2-Door, 8436 2-Door, & 8436 52" 1-Door	2.4	1.1	
475146	5" x 10" Strap for 2 Door Insulation (1 bolt & nut req'd) Used on Models 7230 2-Door, 8436 2-Door, & 8436 52" 1-Door	1.5	0.7	
475147	3/8" SS Nut & Bolt for Insulation Straps	0.0	0.0	

BURN MIZER CREMATOR STACK PIPE

Stack Pipe Without Flange Ring

ITEM	6" STACK DIAMETER			8" STACK DIAMETER			10" STACK DIAMETER					
	CATALOG NUMBER	SHIP WGT		LIST PRICE	CATALOG NUMBER	SHIP WGT		LIST PRICE	CATALOG NUMBER	SHIP WGT		LIST PRICE
		LBS.	KG.			LBS.	KG.			LBS.	KG.	
1'	475065-01	19.0	8.6		475066-01	29.0	13.2		475068-01	40.5	18.4	
2'	475065-02	38.0	17.2		475066-02	58.0	26.3		475068-02	81.0	36.7	
3'	475065-03	57.0	25.9		475066-03	87.0	39.5		475068-03	121.5	55.1	
4'	475065-04	76.0	34.5		475066-04	116.0	52.6		475068-04	161.9	73.4	
5'	475065-05	95.0	43.1		475066-05	145.0	65.8		475068-05	145.0	65.8	
6'	475065-06	114.0	51.7		475066-06	174.0	78.9		475068-06	243.0	110.2	
7'	475065-07	133.0	60.3		475066-07	203.0	92.1		475068-07	283.0	128.4	
8'	475065-08	152.0	68.9		475066-08	232.0	105.2		475068-08	324.0	147.0	

Stack Pipe With Welded Flange Ring

ITEM	6" STACK DIAMETER			8" STACK DIAMETER			10" STACK DIAMETER					
	CATALOG NUMBER	SHIP WGT		LIST PRICE	CATALOG NUMBER	SHIP WGT		LIST PRICE	CATALOG NUMBER	SHIP WGT		LIST PRICE
		LBS.	KG.			LBS.	KG.			LBS.	KG.	
1'	475065F-01	21.0	9.5		475066F-01	31.0	14.1		475068F-01	46.0	20.9	
2'	475065F-02	40.0	18.1		475066F-02	60.0	27.2		475068F-02	87.0	39.5	
3'	475065F-03	59.0	26.8		475066F-03	89.0	40.4		475068F-03	127.0	57.6	
4'	475065F-04	78.0	35.4		475066F-04	118.0	53.5		475068F-04	168.0	76.2	
5'	475065F-05	97.0	44.0		475066F-05	147.0	66.7		475068F-05	208.0	94.3	
6'	475065F-06	116.0	52.6		475066F-06	176.0	79.8		475068F-06	249.0	112.9	
7'	475065F-07	135.0	61.2		475066F-07	205.0	93.0		475068F-07	289.0	131.1	
8'	475065F-08	154.0	69.9		475066F-08	234.0	106.1		475068F-08	330.0	149.7	

FLANGE RINGS

CATALOG NUMBER	ITEM DESCRIPTION	SHIP WGT		LIST PRICE
		LBS.	KG.	
4751530	Flange Only for 6" Stack Pipe	5.0	2.3	
4751532	Flange Only for 8" Stack Pipe	55.0	24.9	
4751531	7" Flange Only - for Repair Directly on Cremator Body Only	0.0	0.0	

STACK NOTES:

- ▶ 6" Stack used on all cremators except Model 10852
- ▶ 8" Stack used on Model 10852 cremator & secondary burners
- ▶ 10" stacks used for model 20 secondary burners only used on 10852 cremators.



This page left intentionally blank