



---

## SECTION 31 LIGHT TRAP

### IN THIS CATALOG SECTION

PAGE NUMBER	CONTENTS
31-02	Light Trap 1" & 1.5" Air Flow Data
31-03	Nightair (Black Out) (Black Out) 1" - Framed Cartridge Pricing (18", 24" & 36" Width)
31-04	Nightair (Black Out) 1" - Framed Cartridge Pricing (48", 52" & 54" Width)
31-05	Nightair (Black Out) 1" - Framed Cartridge Pricing (60", 72", & 84" Width)
31-06	Eclipse (Brown Out) 1.5" - Framed Cartridge Pricing (48" Width)
31-07	Eclipse (Brown Out) 1.5" - Parts
31-08	Nightair (Black Out) 1" - Rod Cartridge Pricing (18", 24" & 36" Width)
31-09	Nightair (Black Out) 1" - Rod Cartridge Pricing (48", 52" & 54" Width)
31-10	Nightair (Black Out) 1" - Rod Cartridge Pricing (60", 72", & 84" Width)
31-11	Components for Nightair (Black Out) Trap
31-12	9" Deep Mounting Bracket Kits & Flush Mount Night Air Transitions

# LIGHT TRAP Airflow Data

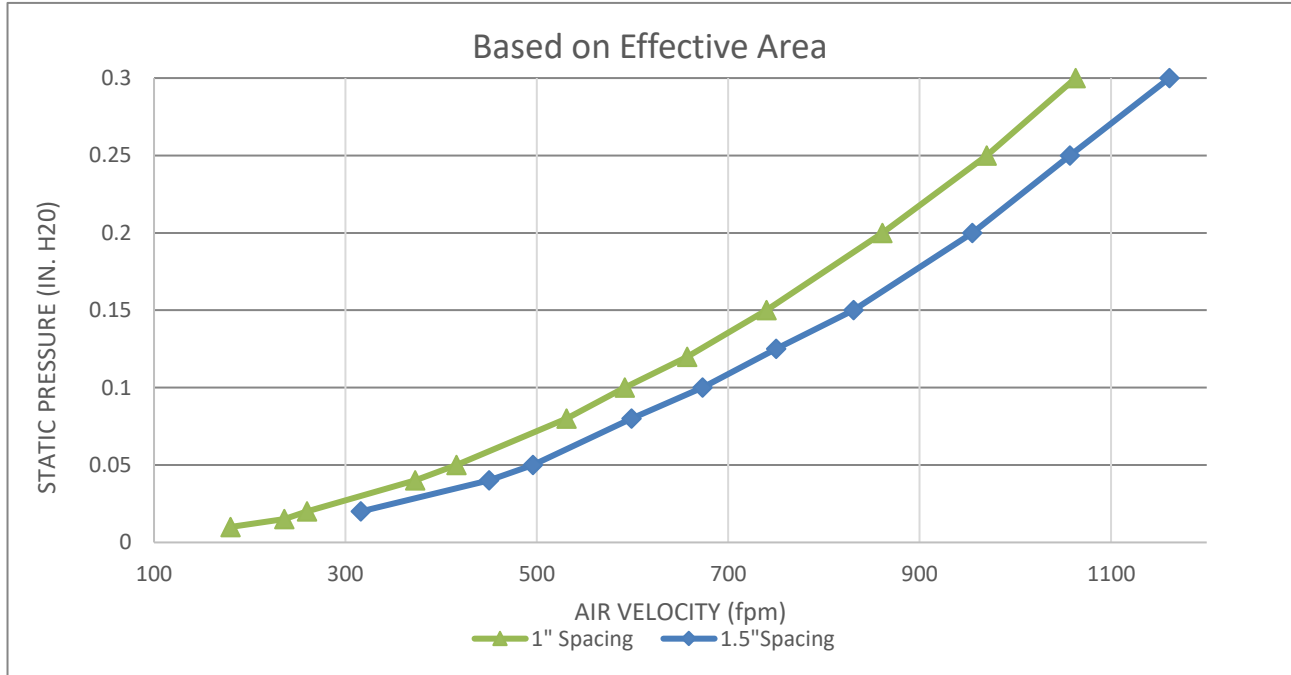

LIGHT REDUCTION FACTOR		
Outside/Inside		
1" Spacing	3,100,000:1	BESS # 04073
1.5" Spacing	2,000:1	BESS # 24095L

## Nightair (Black Out) - 1" FRAMED CARTRIDGE

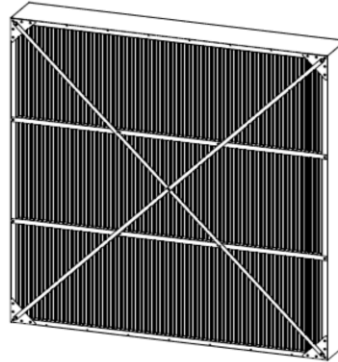

### NIGHTAIR - FRAMED CARTRIDGE

ALL DIMENSIONS ARE +/- 1/8"

WIDTH IN	HEIGHT IN	AREA FT <sup>2</sup>	SHIP WEIGHT		ASSEMBLED FRAMED		UNASSEMBLED FRAMED	
			Lbs.	Kgs	1" SPACING		1" SPACING	
					PART NO.	LIST PRICE	PART NO.	LIST PRICE
18	18	2.25	8.2	3.7	NAK18B18F		NAK18B18FU	
18	24	3.00	19.6	8.9	NAK18B24F		NAK18B24FU	
18	36	4.50	26.6	12.1	NAK18B36F		NAK18B36FU	
18	48	6.00	33.5	15.2	NAK18B48F		NAK18B48FU	
18	52	6.50	35.7	16.2	NAK18B52F		NAK18B52FU	
18	54	6.75	36.1	16.4	NAK18B54F		NAK18B54FU	
18	60	7.50	43.0	19.5	NAK18B60F		NAK18B60FU	
18	72	9.00	50.2	22.8	NAK18B72F		NAK18B72FU	
18	84	10.50	58.4	26.5	NAK18B84F		NAK18B84FU	
24	18	3.00	9.3	4.2	NAK24B18F		NAK24B18FU	
24	24	4.00	24.3	11.0	NAK24B24F		NAK24B24FU	
24	36	6.00	33.4	15.1	NAK24B36F		NAK24B36FU	
24	48	8.00	42.2	19.1	NAK24B48F		NAK24B48FU	
24	52	8.67	44.4	20.1	NAK24B52F		NAK24B52FU	
24	54	9.00	44.8	20.3	NAK24B54F		NAK24B54FU	
24	60	10.00	53.7	24.4	NAK24B60F		NAK24B60FU	
24	72	12.00	62.7	28.4	NAK24B72F		NAK24B72FU	
24	84	14.00	62.7	28.4	NAK24B84F		NAK24B84FU	
36	18	4.50	11.5	5.2	NAK36B18F		NAK36B18FU	
36	24	6.00	33.8	15.3	NAK36B24F		NAK36B24FU	
36	36	9.00	46.9	21.3	NAK36B36F		NAK36B36FU	
36	48	12.00	47.1	21.4	NAK36B48F		NAK36B48FU	
36	52	13.00	63.5	28.8	NAK36B52F		NAK36B52FU	
36	54	13.50	64.0	29.0	NAK36B54F		NAK36B54FU	
36	60	15.00	77.3	35.1	NAK36B60F		NAK36B60FU	
36	72	18.00	90.2	40.9	NAK36B72F		NAK36B72FU	
36	84	21.00	105.0	47.6	NAK36B84F		NAK36B84FU	

SEE COMPONENTS ON PAGE 31-10

## Nightair (Black Out) - 1" FRAMED CARTRIDGE

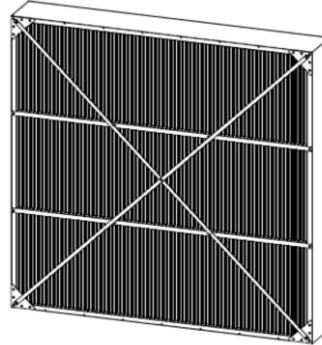

### NIGHTAIR - FRAMED CARTRIDGE

ALL DIMENSIONS ARE +/- 1/8"

WIDTH IN	HEIGHT IN	AREA FT <sup>2</sup>	SHIP WEIGHT		ASSEMBLED FRAMED		UNASSEMBLED FRAMED	
			Lbs.	Kgs	1" SPACING		1" SPACING	
					PART NO.	LIST PRICE	PART NO.	LIST PRICE
48	18	6.00	13.8	6.3	NAK48B18F		NAK48B18FU	
48	24	8.00	43.2	19.6	NAK48B24F		NAK48B24FU	
48	36	12.00	62.3	28.3	NAK48B36F		NAK48B36FU	
48	48	16.00	102.5	46.5	NAK48B48F		NAK48B48FU	
48	52	17.33	79.5	36.1	NAK48B52F		NAK48B52FU	
48	54	18.00	80.0	36.3	NAK48B54F		NAK48B54FU	
48	60	20.00	100.0	45.4	NAK48B60F		NAK48B60FU	
48	72	24.00	171.3	77.7	NAK48B72F		NAK48B72FU	
48	84	28.00	129.7	58.8	NAK48B84F		NAK48B84FU	
52	18	6.50	16.8	7.6	NAK52B18F		NAK52B18FU	
52	24	8.67	48.7	22.1	NAK52B24F		NAK52B24FU	
52	36	13.00	69.6	31.6	NAK52B36F		NAK52B36FU	
52	48	17.33	87.1	39.5	NAK52B48F		NAK52B48FU	
52	52	18.78	92.3	41.9	NAK52B52F		NAK52B52FU	
52	54	19.50	88.4	40.1	NAK52B54F		NAK52B54FU	
52	60	21.67	107.5	48.8	NAK52B60F		NAK52B60FU	
52	72	26.00	125.1	56.7	NAK52B72F		NAK52B72FU	
52	84	30.33	145.6	66.0	NAK52B84F		NAK52B84FU	
54	18	6.75	17.3	7.8	NAK54B18F		NAK54B18FU	
54	24	9.00	50.4	22.9	NAK54B24F		NAK54B24FU	
54	36	13.50	72.0	32.7	NAK54B36F		NAK54B36FU	
54	48	18.00	90.1	40.9	NAK54B48F		NAK54B48FU	
54	52	19.50	90.9	41.2	NAK54B52F		NAK54B52FU	
54	54	20.25	91.3	41.4	NAK54B54F		NAK54B54FU	
54	60	22.50	111.0	50.3	NAK54B60F		NAK54B60FU	
54	72	27.00	129.0	58.5	NAK54B72F		NAK54B72FU	
54	84	31.50	150.0	68.0	NAK54B84F		NAK54B84FU	

SEE COMPONENTS ON PAGE 31-10

## Nightair (Black Out) - 1" FRAMED CARTRIDGE

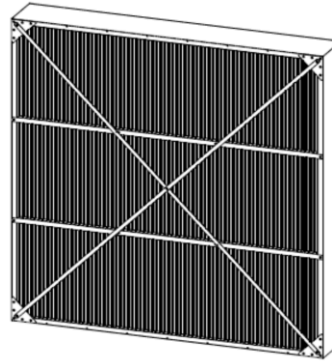

### NIGHTAIR - FRAMED CARTRIDGE

ALL DIMENSIONS ARE +/- 1/8"

WIDTH IN	HEIGHT IN	AREA FT <sup>2</sup>	SHIP WEIGHT		ASSEMBLED FRAMED		UNASSEMBLED FRAMED	
			Lbs.	Kgs	1" SPACING		1" SPACING	
					PART NO.	LIST PRICE	PART NO.	LIST PRICE
60	18	7.50	18.6	8.4	NAK60B18F		NAK60B18FU	
60	24	10.00	55.3	25.1	NAK60B24F		NAK60B24FU	
60	36	15.00	79.2	35.9	NAK60B36F		NAK60B36FU	
60	48	20.00	98.4	44.6	NAK60B48F		NAK60B48FU	
60	52	21.67	100.0	45.4	NAK60B52F		NAK60B52FU	
60	54	22.50	100.0	45.4	NAK60B54F		NAK60B54FU	
60	60	25.00	122.2	55.4	NAK60B60F		NAK60B60FU	
60	72	30.00	142.3	64.5	NAK60B72F		NAK60B72FU	
60	84	35.00	165.7	75.2	NAK60B84F		NAK60B84FU	
72	18	9.00	20.2	9.2	NAK72B18F		NAK72B18FU	
72	24	12.00	64.1	29.1	NAK72B24F		NAK72B24FU	
72	36	18.00	92.3	41.9	NAK72B36F		NAK72B36FU	
72	48	24.00	115.8	52.5	NAK72B48F		NAK72B48FU	
72	52	26.00	116.6	52.9	NAK72B52F		NAK72B52FU	
72	54	27.00	117.0	53.1	NAK72B54F		NAK72B54FU	
72	60	30.00	142.9	64.8	NAK72B60F		NAK72B60FU	
72	72	36.00	167.0	75.7	NAK72B72F		NAK72B72FU	
84	18	10.50	24.0	10.9	NAK84B18F		NAK84B18FU	
84	24	14.00	73.3	33.2	NAK84B24F		NAK84B24FU	
84	36	21.00	106.0	48.1	NAK84B36F		NAK84B36FU	
84	48	28.00	132.0	59.9	NAK84B48F		NAK84B48FU	
84	52	30.33	133.0	60.3	NAK84B52F		NAK84B52FU	
84	54	31.50	134.0	60.8	NAK84B54F		NAK84B54FU	
84	60	35.00	164.0	74.4	NAK84B60F		NAK84B60FU	

SEE COMPONENTS ON PAGE 31-10

## ECLIPSE (Brown Out) - 1.5" FRAMED CARTRIDGE

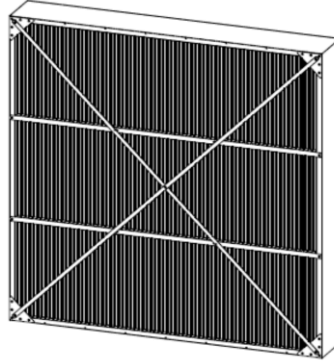

**ECLIPSE - FRAMED CARTRIDGE**

ALL DIMENSIONS ARE +/- 1/8"

WIDTH IN	HEIGHT IN	AREA FT <sup>2</sup>	SHIP WEIGHT		ASSEMBLED FRAMED		UNASSEMBLED FRAMED	
			Lbs.	Kgs	1.5" SPACING		1.5" SPACING	
					PART NO.	LIST PRICE	PART NO.	LIST PRICE
48	48	16.00	#N/A		81948X48F		81948X48FU	
48	72	24.00	#N/A		81948X72F		81948X72FU	

## Nightair (Brown Out) - TRAP

### 1.5" FRAMED COMPONENTS

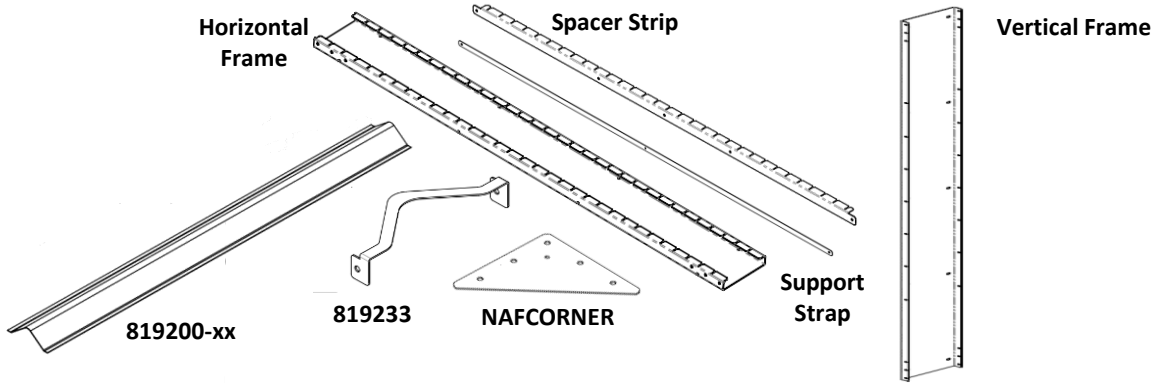

Decription	Part Number									List Price
#12 X 1/2" Screw	690276									
3/16" Rivet	954099									
Wavy Spacer	819233									
Corner Brace	NAFCORNER									
<b>Height</b>	<b>18"</b>	<b>24"</b>	<b>36"</b>	<b>48"</b>	<b>52"</b>	<b>54"</b>	<b>60"</b>	<b>72"</b>	<b>84"</b>	
Black PVC Panel				819200-48				819200-72		CALL
Vertical Frame				819267				819158		CALL
<b>Width</b>	<b>18"</b>	<b>24"</b>	<b>36"</b>	<b>48"</b>	<b>52"</b>	<b>54"</b>	<b>60"</b>	<b>72"</b>	<b>84"</b>	
Horizontal Frame, 1.5"				819246				819246		CALL
Spacer Strip, 1.5"				819248				819248		CALL

## Nightair (Black Out) - & 1" ROD CARTRIDGE

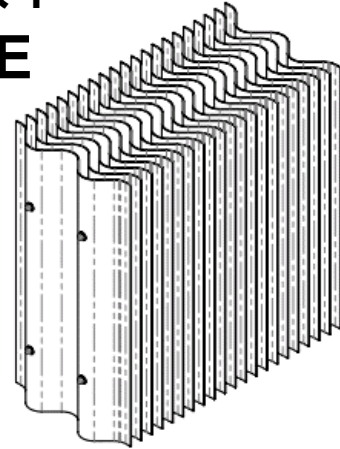

### NIGHTAIR - ROD CARTRIDGE

ALL DIMENSIONS ARE +/- 1/8"

WIDTH IN	HEIGHT IN	AREA FT <sup>2</sup>	SHIP WEIGHT		UNASSEMBLED ROD	
			Lbs.	Kgs	1" SPACING	
					PART NO.	LIST PRICE
18	18	2.25	8.4	3.8	81918B18RU	
18	24	3.00	10.80	4.9	81918B24RU	
18	36	4.50	15.60	7.1	81918B36RU	
18	48	6.00	21.10	9.6	81918B48RU	
18	52	6.50	22.70	10.3	81918B52RU	
18	54	6.75	23.50	10.7	81918B54RU	
18	60	7.50	33.30	15.1	81918B60RU	
18	72	9.00	30.70	13.9	81918B72RU	
18	84	10.50	336.00	152.4	81918B84RU	
24	18	3.00	11.50	5.2	81924B18RU	
24	24	4.00	14.80	6.7	81924B24RU	
24	36	6.00	21.40	9.7	81924B36RU	
24	48	8.00	28.90	13.1	81924B48RU	
24	52	8.67	31.10	14.1	81924B52RU	
24	54	9.00	32.20	14.6	81924B54RU	
24	60	10.00	35.50	16.1	81924B60RU	
24	72	12.00	42.10	19.1	81924B72RU	
24	84	14.00	49.40	22.4	81924B84RU	
36	18	4.50	17.80	8.1	81936B18RU	
36	24	6.00	22.90	10.4	81936B24RU	
36	36	9.00	33.10	15.0	81936B36RU	
36	48	12.00	44.70	20.3	81936B48RU	
36	52	13.00	48.10	21.8	81936B52RU	
36	54	13.50	49.80	22.6	81936B54RU	
36	60	15.00	54.90	24.9	81936B60RU	
36	72	18.00	65.10	29.5	81936B72RU	
36	84	21.00	76.30	34.6	81936B84RU	

SEE COMPONENTS ON PAGE 31-10

# Nightair (Black Out) - 1" ROD CARTRIDGE

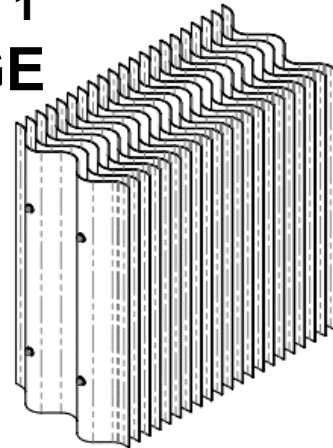

## NIGHTAIR - ROD CARTRIDGE

ALL DIMENSIONS ARE +/- 1/8"

					UNASSEMBLED ROD	
WIDTH IN	HEIGHT IN	AREA FT <sup>2</sup>	SHIP WEIGHT		1" SPACING	
			Lbs.	Kgs	PART NO.	LIST PRICE
48	18	6.0	23.6	10.7	81948B18RU	
48	24	8.0	30.3	13.7	81948B24RU	
48	36	12.0	43.8	19.9	81948B36RU	
48	48	16.0	59.2	26.9	81948B48RU	
48	52	17.3	63.7	28.9	81948B52RU	
48	54	18.0	65.9	29.9	81948B54RU	
48	60	20.0	72.7	33.0	81948B60RU	
48	72	24.0	86.2	39.1	81948B72RU	
48	84	28.0	101.1	45.9	81948B84RU	
52	18	6.5	25.7	11.7	81952B18RU	
52	24	8.7	33.0	15.0	81952B24RU	
52	36	13.0	47.7	21.6	81952B36RU	
52	48	17.3	64.5	29.3	81952B48RU	
52	52	18.8	69.4	31.5	81952B52RU	
52	54	19.5	71.8	32.6	81952B54RU	
52	60	21.7	79.2	35.9	81952B60RU	
52	72	26.0	93.9	42.6	81952B72RU	
52	84	30.3	110.1	49.9	81952B84RU	
54	18	6.8	26.7	12.1	81954B18RU	
54	24	9.0	34.3	15.6	81954B24RU	
54	36	13.5	49.6	22.5	81954B36RU	
54	48	18.0	67.0	30.4	81954B48RU	
54	52	19.5	72.1	32.7	81954B52RU	
54	54	20.3	74.7	33.9	81954B54RU	
54	60	22.5	82.3	37.3	81954B60RU	
54	72	27.0	97.6	44.3	81954B72RU	
54	84	31.5	114.6	52.0	81954B84RU	

SEE COMPONENTS ON PAGE 31-10

# Nightair (Black Out) - 1" ROD CARTRIDGE

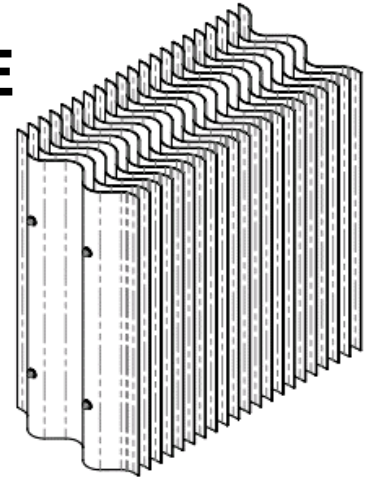

## NIGHTAIR - ROD CARTRIDGE

ALL DIMENSIONS ARE +/- 1/8"

					<b>UNASSEMBLED ROD</b>	
<b>WIDTH IN</b>	<b>HEIGHT IN</b>	<b>AREA FT<sup>2</sup></b>	<b>SHIP WEIGHT</b>		<b>1" SPACING</b>	
			<b>Lbs.</b>	<b>Kgs</b>	<b>PART NO.</b>	<b>LIST PRICE</b>
60	18	7.5	29.4	13.3	81960B18RU	
60	24	10.0	37.8	17.1	81960B24RU	
60	36	15.0	54.6	24.8	81960B36RU	
60	48	20.0	73.7	33.4	81960B48RU	
60	52	21.7	79.3	36.0	81960B52RU	
60	54	22.5	82.1	37.2	81960B54RU	
60	60	25.0	90.5	41.1	81960B60RU	
60	72	30.0	107.3	48.7	81960B72RU	
60	84	35.0	125.9	57.1	81960B84RU	
72	18	9.0	35.6	16.1	81972B18RU	
72	24	12.0	45.8	20.8	81972B24RU	
72	36	18.0	66.2	30.0	81972B36RU	
72	48	24.0	89.4	40.6	81972B48RU	
72	52	26.0	96.2	43.6	81972B52RU	
72	54	27.0	99.6	45.2	81972B54RU	
72	60	30.0	109.8	49.8	81972B60RU	
72	72	36.0	130.2	59.1	81972B72RU	
84	18	10.5	41.4	18.8	81984B18RU	
84	24	14.0	53.2	24.1	81984B24RU	
84	36	21.0	76.9	34.9	81984B36RU	
84	48	28.0	104.0	47.2	81984B48RU	
84	52	30.3	111.9	50.8	81984B52RU	
84	54	31.5	115.8	52.5	81984B54RU	
84	60	35.0	127.7	57.9	81984B60RU	

SEE COMPONENTS ON PAGE 31-10

## Nightair (Black Out) - TRAP

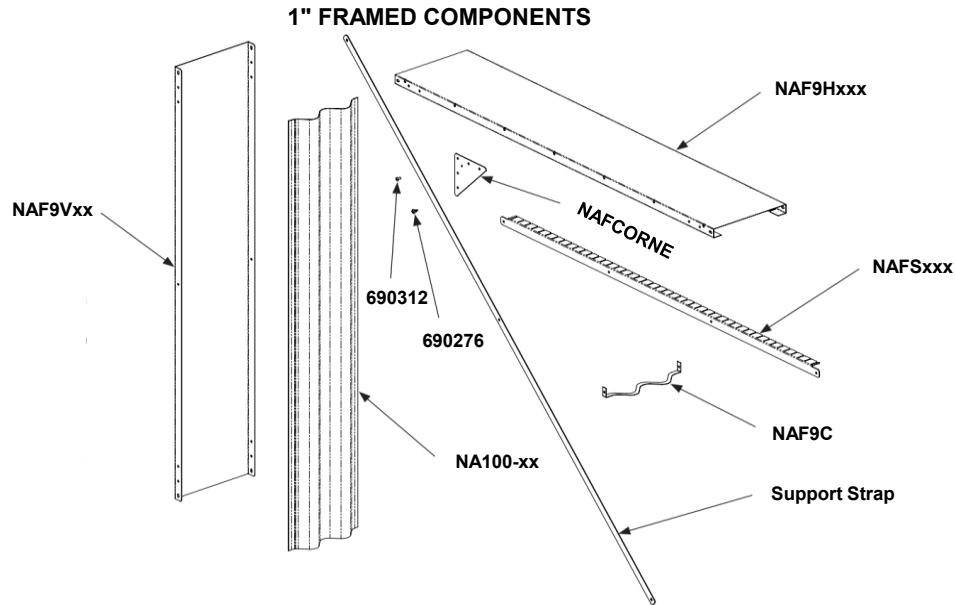

Decription	Part Number										List Price
#12 X 1/2" Screw	690276										
3/16" Rivet	690312										
Wavy Spacer	NAF9C										
Corner Brace	NAFCORNER										
<b>Height</b>	<b>18"</b>	<b>24"</b>	<b>36"</b>	<b>48"</b>	<b>52"</b>	<b>54"</b>	<b>60"</b>	<b>72"</b>	<b>84"</b>		
Black PVC Panel	NA100-18	NA100-24	NA100-36	NA100-48	NA100-52	NA100-54	NA100-60	NA100-72F	NA100-84F	CALL	
Vertical Frame	NAF9V18	NAF9V24	NAF9V36	NAF9V48	NAF9V52	NAF9V54	NAF9V60	NAF9V72	NAF9V84	CALL	
<b>Width</b>	<b>18"</b>	<b>24"</b>	<b>36"</b>	<b>48"</b>	<b>52"</b>	<b>54"</b>	<b>60"</b>	<b>72"</b>	<b>84"</b>		
Horizontal Frame, 1"	NAF9H18B	NAF9H24B	NAF9H36B	NAF9H48B	NAF9H52B	NAF9H54B	NAF9H60B	NAF9H72B	NAF9H84B	CALL	
Spacer Strip, 1"	NAFS18B	NAFS24B	NAFS36B	NAFS48B	NAFS52B	NAFS54B	NAFS60B	NAFS72B	NAFS84B	CALL	

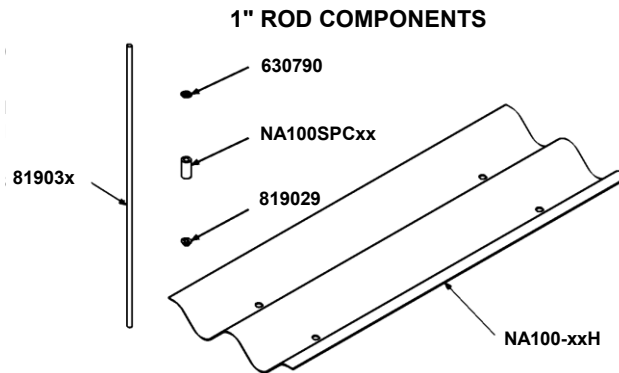

Decription	Part Number										List Price
Push on Retainer	630790										
1/4" Retainer Push Cap	819029										
1" Tall Spacer	NA100SPC1										
<b>Width</b>	<b>18"</b>	<b>24"</b>	<b>36"</b>	<b>48"</b>	<b>52"</b>	<b>54"</b>	<b>60"</b>	<b>72"</b>	<b>84"</b>		
1/4" Galvanized Rod	819030	819031	819032	819033	819034	819035	819036	819037	819038	CALL	
<b>Height</b>	<b>18"</b>	<b>24"</b>	<b>36"</b>	<b>48"</b>	<b>52"</b>	<b>54"</b>	<b>60"</b>	<b>72"</b>	<b>84"</b>		
Black PVC Panel	NA100-18H	NA100-24H	NA100-36H	NA100-48H	NA100-52H	NA100-54H	NA100-60H	NA100-72H	NA100-84H	CALL	



## LIGHT TRAP KITS FOR IN FRONT OF EXHAUST FANS

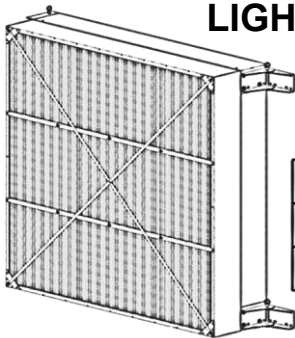

	A (Width Clearance)		B (Height Clearance)		C (Clearance in Closed Position)		D (Clearance in Open Position)	
	in	cm	in	cm	in	cm	in	cm
819000 72" x 72"	84	213.4	74.5	189.2	19	48.3	79	200.7
819010 60" x 60"	72	182.9	62.5	158.8	19	48.3	67	170.2
819020 48" x 48"	60	152.4	50.5	128.3	19	48.3	55	139.7

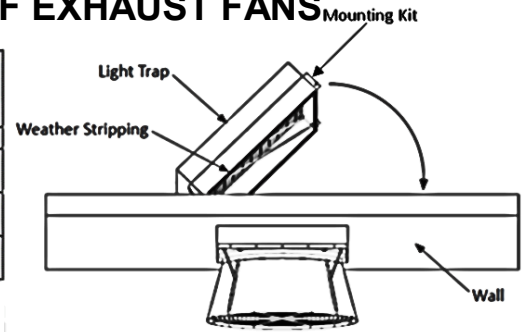

**How to Order:** - Order (1) Mounting Kit and (1) Framed Light Trap. Fan and shutters sold separately.

### MOUNTING KITS - Ships Unassembled - ONLY USED WITH FRAMED LIGHT TRAPS

CATALOG NUMBER	ITEM DESCRIPTION	Typical Size Exhaust Fan	SHIP WEIGHT		LIST PRICE
			LBS.	KGS.	
819020	9" Deep Mounting Kit for 48" x 48" Framed Light Trap	12" - 24"	64.3	30.0	
NAK48B48F	Light Trap 48H x 48W x 1" Spacing Galvanized Frame Assembled		102.5	47.0	
NAK48B48FU	Light Trap 48H x 48W x 1" Spacing Galvanized Frame Unassembled		78.6	36.0	
819010	9" Deep Mounting Kit for 60" x 60" Framed Light Trap	36" - 48"	82.2	38.0	
NAK60B60F	Light Trap 60H x 60W x 1" Spacing Galvanized Frame Assembled		122.2	56.0	
NAK60B60FU	Light Trap 60H x 60W x 1" Spacing Galvanized Frame Unassembled		122.2	56.0	
819000	9" Deep Mounting Kit for 72" x 72" Framed Light Trap	50" - 54"	95.6	44.0	
NAK72B72F	Light Trap 72H x 72W x 1" Spacing Galvanized Frame Assembled		167.0	76.0	
NAK72B72FU	Light Trap 72H x 72W x 1" Spacing Galvanized Frame Unassembled		166.7	76.0	

Light Traps in front of Exhaust Fans will increase the static pressure, see page 31-02 for air flow data or contact VAL-CO App. Engineering . Hinged design. Sits into Room 18" when door is closed

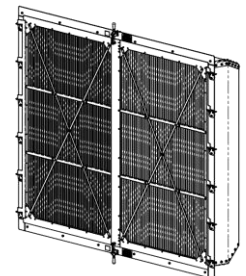

**How to Order:** - Order (1) Flush Mount Framed Light Trap. Fan & Shutters sold separately.

### FLUSH MOUNT NightAir FAN TRANSITIONS (Black-out)- Ships Unassembled

CATALOG NUMBER	ITEM DESCRIPTION	Typical Size Exhaust Fan	SHIP WEIGHT		LIST PRICE
			LBS.	KGS.	
819085	Flush Mount Framed Light Trap 42H x 42W x 1" - unassembled	24" FG Fans	262.0	119.0	
819025	Flush Mount Framed Light Trap 48H x 48W x 1" - unassembled	24" FG Fans	260.0	118.0	
819075	Flush Mount Framed Light Trap 60H x 72W x 1" - unassembled	36" FG Fans	335.0	152.0	
819045	Flush Mount Framed Light Trap 84H x 72W x 1" - unassembled	54" FG Fans	475.0	216.0	

### FLUSH MOUNT ECLIPSE FAN TRANSITIONS (Brown-out) - Ships Unassembled

819225	Flush Mount Framed Light Trap 42H x 42W x 1" - unassembled	24" FG Fans	242.0	110.0	
819215	Flush Mount Framed Light Trap 60H x 72W x 1" - unassembled	36" FG Fans	335.0	152.0	
819245	Flush Mount Framed Light Trap 72H x 72W x 1" - unassembled	54" FG Fans	273.0	124.0	
819255	Flush Mount Framed Light Trap 84H x 72W x 1" - unassembled	54" FG Fans	355.0	162.0	

Light Traps in front of Exhaust Fans will increase the static pressure, see page 31-02 for air flow data or contact VAL-CO App. Engineering . Light Trap is included. Hinged design. **For Fiberglass fans only. Please contact VAL-Co Engineering to use with galvanized fan.**

### ADAPTER KITS

819240	Adapter kit to mount a Mach 57 Fan to either 819045 or 819255	57" FG Fans	25.5	12.0	
819265	Conversion Kit, Flush Eclipse - RO=52.25" W x 51" H	24" FG Fans	81.1	37.0	
819260	Adapter kit to mount a 50" Interior Mount fan to a 819045 / 819255 transition	57" FG Fans	26.4	12.0	