

---

## SECTION 30 INLET ACTUATORS & CURTAIN MACHINES

### IN THIS CATALOG SECTION

PAGE NUMBER	CONTENTS
30-02	Selecting the Correct Curtain Machine/Inlet Actuator
30-03	Selection Chart - ATLAS Ball & ACME Curtain Machines
30-04	ATLAS - Ball Screw Curtain Machines (WEATHER RESISTANT) 1A Control Machines compatible with EDGE house controllers
30-05	ATLAS - Acme Screw Curtain Machines (WEATHER RESISTANT)
30-06	Curtain Machine Options
30-07	Selection Chart - SafeTRAC Gen III ACME Screw Curtain Machines
30-08	SafeTRAC - 220v Acme Screw Curtain Machines (INDOOR ONLY)
30-09	SafeTRAC - 110v Acme Screw Curtain Machines (INDOOR ONLY)
30-10	Linear Actuators - Vent, Chimney, Inlet Actuators Selection Chart - Linear Actuators
30-11 thru 03-12	Curtain Machine Winching Examples

## INLET ACTUATORS & CURTAIN MACHINES

### SELECTING THE CORRECT CURTAIN MACHINE/INLET ACTUATOR

#### **CURTAIN MACHINES**

**Ball Screw:** The ATLAS ball screw based machine is a high quality machine using a ball screw drive for efficient and quiet operation. With regular maintenance, the ball screw will give a long life in any application.

**ACME Screw:** The ATLAS ACME screw based machines are economical machines that will give a long life with minimal maintenance.

#### **SIZING YOUR MACHINE**

Use the table on pages 30-03 & 30-06 to compare the sizes and capacities of the different machines.

- (1) Select the category of machine that meets your requirements from above.
- (2) The table has three columns for Travel Distance. Under the Pulley Ratio that matches your requirements, find the travel distance that you need.
- (3) The column to the left of the travel distance is the travel per minute column. Select the travel per minute that you will need.

#### **IMPORTANT NOTES**

For 1:1 ratio - speed remains 1:1 - capacity remains 1:1 - total travel remains 1:1.

For 1:2 ratio - speed increases 2x - capacity decreases 50% - total travel increases 2x.

For 2:1 ratio - speed decrease 50% - capacity remains 1:1 - total travel decreases 50%.

# ATLAS™ CURTAIN MACHINES

## SELECTING THE CORRECT ATLAS CURTAIN MACHINE

CURTAIN MACHINE SELECTION TABLE						Speed Increases 200%				Speed Decreases 50%			
						Capacity Decreases 50%				Capacity Remains 100%			
		PULLEY RATIO 1:1				PULLEY RATIO 1:2				PULLEY RATIO 2:1			
TYPE	LENGTH	TRAVEL IN/MIN * 60 Hz	TRAVEL IN/MIN * 50 Hz	TRAVEL IN	RATED CAPACITY LBS.	TRAVEL IN/MIN * 60 Hz	TRAVEL IN/MIN * 50 Hz	TRAVEL IN	RATED CAPACITY LBS.	TRAVEL IN/MIN * 60 Hz	TRAVEL IN/MIN * 50 Hz	TRAVEL IN	RATED CAPACITY LBS.
ATLAS - BALL SCREW SERIES	24	6.0	5.0	22	4000	12.0	10.0	44	2000	3.0	2.5	11	4000
	36	6.0	5.0	34	4000	12.0	10.0	68	2000	3.0	2.5	17	4000
	48	6.0	5.0	46	4000	12.0	10.0	92	2000	3.0	2.5	23	4000
	72	6.0	5.0	70	4000	12.0	10.0	140	2000	3.0	2.5	35	4000
ATLAS - ACME SCREW SERIES (220V)	24	4.8	4.0	22	4000	9.6	8.0	44	2000	2.4	2.0	11	4000
	36	4.8	4.0	34	4000	9.6	8.0	68	2000	2.4	2.0	17	4000
	48	4.8	4.0	46	4000	9.6	8.0	92	2000	2.4	2.0	23	4000
	72	4.8	4.0	70	4000	9.6	8.0	140	2000	2.4	2.0	35	4000
ATLAS - ACME SCREW SERIES (110V)	24	5.0	N/A	22	4000	10.0	N/A	44	2000	2.5	N/A	11	4000
	36	5.0	N/A	34	4000	10.0	N/A	68	2000	2.5	N/A	17	4000
	48	5.0	N/A	46	4000	10.0	N/A	92	2000	2.5	N/A	23	4000
	72	5.0	N/A	70	4000	10.0	N/A	140	2000	2.5	N/A	35	4000

\* Travel speeds are calculated based on motor and reducer nameplate ratings at 50/60Hz; travel speeds may vary by up to +20% (travel speeds for 1:2 and 2:1 pulley ratios are based on the calculated speeds of the 1:1 pulley ratio)

## ATLAS™ WEATHER RESISTANT BALL SCREW CURTAIN MACHINES

**NOTES:**

1. All ATLAS Ball Screw Curtain Machines are standard 220V, 50/60Hz, 1 Phase ONLY.
2. All machines standard with Auto/Manual and Open/Close local control switches.
3. Sprocket & chain drive available.
4. WEATHER RESISTANT - ATLAS Curtain Machines use weather resistant limit switches and include a circuit board that is in a weather resistant enclosure.
5. **Optional Clutch** available to allow curtain to slowly drop when power is lost and return to position when power is restored.

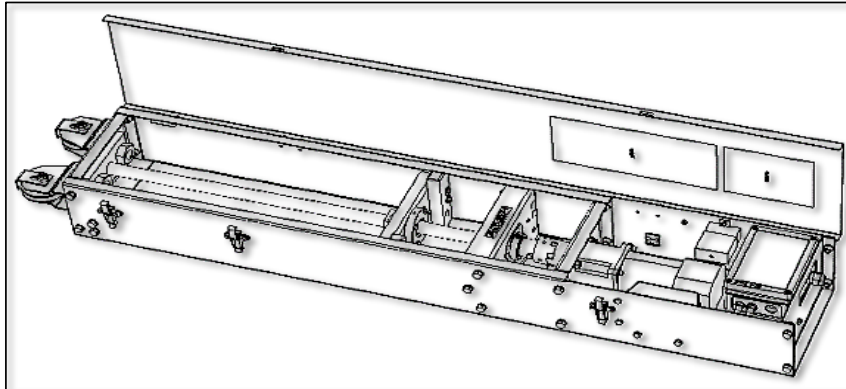

### BALL SCREW CURTAIN MACHINES

CATALOG #	ITEM DESCRIPTION	SHIP WEIGHT		LIST PRICE
		LBS.	KG.	
970508-24	Curtain Machine 24", Ball Screw, 50/60Hz, 5/6 IN/MIN, 25/30 RPM	79.7	36.1	
970512-24	With Optional Sprocket & Chain Drive	79.9	36.2	
970516-24	Curtain Machine 24", Ball Screw w/ <b>Clutch</b> , 50/60Hz, 5/6IN/MIN, 25/30 RPM	83.9	38.1	
970520-24	With Optional Sprocket & Chain Drive	83.8	38.0	
970508-36	Curtain Machine 36", Ball Screw, 50/60Hz, 5/6 IN/MIN, 25/30 RPM	81.4	36.9	
970512-36	With Optional Sprocket & Chain Drive	81.6	37.0	
970516-36	Curtain Machine 36", Ball Screw w/ <b>Clutch</b> , 50/60Hz, 5/6 IN/MIN, 25/30 RPM	107.0	48.5	
970520-36	With Optional Sprocket & Chain Drive	85.2	38.7	
970508-48	Curtain Machine 48", Ball Screw, 50/60Hz, 5/6 IN/MIN, 25/30 RPM	87.6	39.7	
970512-48	With Optional Sprocket & Chain Drive	87.2	39.6	
970516-48	Curtain Machine 48", Ball Screw w/ <b>Clutch</b> , 50/60Hz, 5/6 IN/MIN, 25/30 RPM	91.8	41.7	
970520-48	With Optional Sprocket & Chain Drive	91.8	41.6	
970508-72	Curtain Machine 72", Ball Screw, 50/60Hz, 5/6 IN/MIN, 25/30 RPM	108.3	49.1	
970512-72	With Optional Sprocket & Chain Drive	108.1	49.0	
970516-72	Curtain Machine 72", Ball Screw w/ <b>Clutch</b> , 50/60Hz, 5/6 IN/MIN, , 25/30 RPM	142.0	64.4	
970520-72	With Optional Sprocket & Chain Drive	112.5	51.0	

### BALL SCREW CURTAIN MACHINES

970516-24-1A	Curtain Machine 24", Ball Screw w/ <b>Clutch</b> , 50/60Hz, 5/6IN/MIN, 25/30 RPM 1A Control Machines compatible with EDGE house controllers	87.2	39.6	
970520-24-1A	With Optional Sprocket & Chain Drive	87.2	39.6	
970516-36-1A	Curtain Machine 36", Ball Screw w/ <b>Clutch</b> , 50/60Hz, 5/6IN/MIN, 25/30 RPM 1A Control Machines compatible with EDGE house controllers	97.9	44.4	
970520-36-1A	With Optional Sprocket & Chain Drive	98.1	44.5	

## ATLAS™ WEATHER RESISTANT ACME SCREW CURTAIN MACHINES

**NOTES:**

1. All ATLAS Acme Screw Curtain Machines are standard 110V 60Hz or 220V, 50/60Hz, 1 Phase ONLY.
2. All machines standard with Auto/Manual and Open/Close local control switches.
3. Sprocket & chain drive available.
4. WEATHER RESISTANT - ATLAS Curtain Machines use weather resistant limit switches and include a circuit board that is in a weather resistant enclosure.

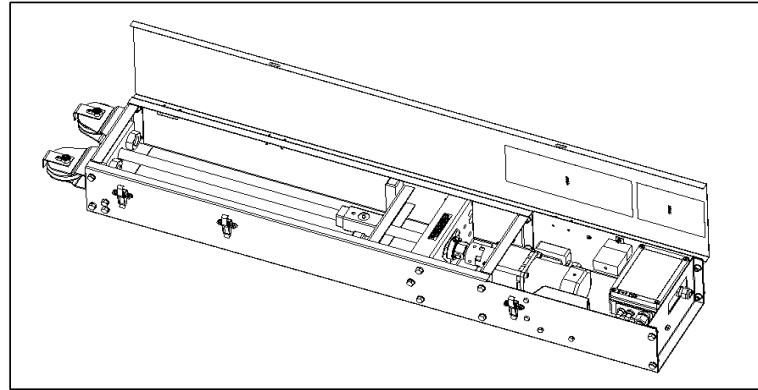

### ACME SCREW CURTAIN MACHINES (220V)

CATALOG #	ITEM DESCRIPTION	SHIP WEIGHT		LIST PRICE
		LBS.	KG.	
970500-24	Curtain Machine 24", Acme Screw, 50/60Hz, 4/4.8 IN/MIN, 25/30 RPM	86.3	39.2	
970504-24	With Optional Sprocket & Chain Drive	86.2	39.1	
970500-36	Curtain Machine 36", Acme Screw, 50/60Hz, 4/4.8 IN/MIN, 25/30 RPM	97.0	44.0	
970504-36	With Optional Sprocket & Chain Drive	96.9	44.0	
970500-48	Curtain Machine 48", Acme Screw, 50/60Hz, 4/4.8 IN/MIN, 25/30 RPM	105.5	47.9	
970504-48	With Optional Sprocket & Chain Drive	105.5	47.8	
970500-72	Curtain Machine 72", Acme Screw, 50/60Hz, 4/4.8 IN/MIN, 25/30 RPM	130.9	59.4	
970504-72	With Optional Sprocket & Chain Drive	130.8	59.3	

### ACME SCREW CURTAIN MACHINES (110V)

CATALOG #	ITEM DESCRIPTION	SHIP WEIGHT		LIST PRICE
		LBS.	KG.	
970501-24	Curtain Machine 24", Acme Screw, 60Hz, 5 IN/MIN, 30 RPM	85.9	39.0	
970505-24	With Optional Sprocket & Chain Drive	85.8	38.9	
970501-36	Curtain Machine 36", Acme Screw, 60Hz, 5 IN/MIN, 30 RPM	96.6	43.8	
970505-36	With Optional Sprocket & Chain Drive	96.5	43.8	
970501-48	Curtain Machine 48", Acme Screw, 60Hz, 5 IN/MIN, 30 RPM	105.1	47.7	
970505-48	With Optional Sprocket & Chain Drive	105.0	47.6	
970501-72	Curtain Machine 72", Acme Screw, 60Hz, 5 IN/MIN, 30 RPM	130.9	59.4	
970505-72	With Optional Sprocket & Chain Drive	130.3	59.1	

## Curtain Machine Options

### OPTIONAL POTENTIOMETER KITS

CATALOG #	ITEM DESCRIPTION	SHIP WEIGHT		LIST PRICE
		LBS.	KG.	
970370	Potentiometer Kit - Spring Loaded for <b>Ball Screw</b> Curtain Machines	1.0	0.5	
970371	Potentiometer Kit - Spring Loaded for <b>ACME Screw</b> Curtain Machines	1.0	0.3	
970156	Potentiometer Only, no Bracket or Gear for ACME and Ball Screw Curtain Machines 24" - 72"	0.0	0.0	

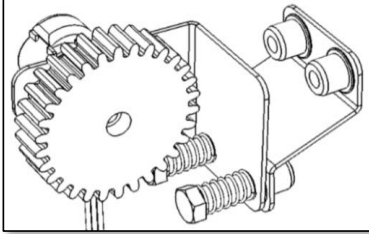

970370

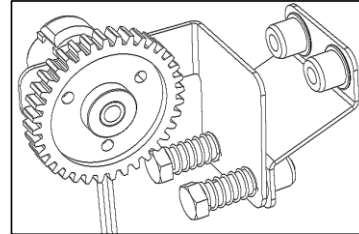

970371 #REF!

### AUXILLARY LIMIT SWITCH

CATALOG #	ITEM DESCRIPTION	SHIP WEIGHT		LIST PRICE
		LBS.	KG.	
970200	Whisker Switch, Normally Closed, 240V @ 15 amps	0.2	0.1	

### OPTIONAL WEATHER GUARD

CATALOG #	ITEM DESCRIPTION	SHIP WEIGHT		LIST PRICE
		LBS.	KG.	
970196	Weather Guard Minimize the amount of moisture that can enter the top of the machine	5.0	2.3	

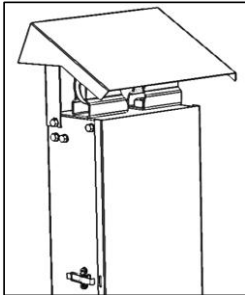

970196

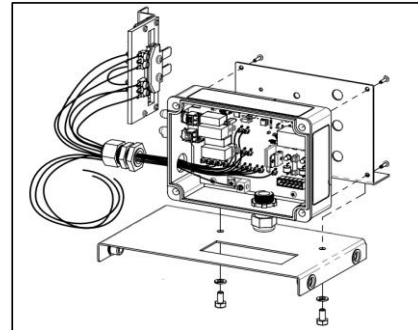

970547 & 970548

### GEN II BOARD CONVERSION KIT TO ATLAS

CATALOG #	ITEM DESCRIPTION	SHIP WEIGHT		LIST PRICE
		LBS.	KG.	
970547	Convert a 220V ACME Gen II board & switch to a single board ATLAS and switch	4.4	2.0	
970548	Convert a 110V ACME Gen II board & switch to a single board ATLAS and switch	4.4	2.0	
970545	Convert a 220V Ball Screw Gen II board & switch to a single board ATLAS and switch	4.4	2.0	

### OPTIONAL SAFETRAC LOCAL CONTROL SWITCH KIT

CATALOG #	ITEM DESCRIPTION	SHIP WEIGHT		LIST PRICE
		LBS.	KG.	
970667	Local Control Switch Kit for ACME Screw Curtain Machines, GEN III INDOOR ONLY	0.3	0.1	

## SAFETRAC GENERATION III INDOOR CURTAIN MACHINES

### SELECTING THE CORRECT SAFETRAC CURTAIN MACHINE

CURTAIN MACHINE SELECTION TABLE					Speed Increases 200% Capacity Decreases 50%				Speed Decreases 50% Capacity Remains 100%				
					Total Travel Increases 200%				Total Travel Decreases 50%				
TYPE	θ	PULLEY RATIO 1:1				PULLEY RATIO 1:2				PULLEY RATIO 2:1			
		TRAVEL IN/MIN * 60 Hz	TRAVEL IN/MIN * 50 Hz	TRAVEL IN	RATED CAPACITY LBS.	TRAVEL IN/MIN * 60 Hz	TRAVEL IN/MIN * 50 Hz	TRAVEL IN	RATED CAPACITY LBS.	TRAVEL IN/MIN * 60 Hz	TRAVEL IN/MIN * 50 Hz	TRAVEL IN	RATED CAPACITY LBS.
SAFETRAC GEN3 - ACME SCREW SERIES (220V)	24	4.8	4.0	22	4000	9.6	8.0	44	2000	2.4	2.0	11	4000
	36	4.8	4.0	34	4000	9.6	8.0	68	2000	2.4	2.0	17	4000
	48	4.8	4.0	46	4000	9.6	8.0	92	2000	2.4	2.0	23	4000
	72	4.8	4.0	70	4000	9.6	8.0	140	2000	2.4	2.0	35	4000
SAFETRAC GEN3 - ACME SCREW SERIES (110V)	24	5.0	N/A	22	4000	10.0	N/A	44	2000	2.5	N/A	11	4000
	36	5.0	N/A	34	4000	10.0	N/A	68	2000	2.5	N/A	17	4000
	48	5.0	N/A	46	4000	10.0	N/A	92	2000	2.5	N/A	23	4000
	72	5.0	N/A	70	4000	10.0	N/A	140	2000	2.5	N/A	35	4000
SAFETRAC GEN3 - ACME SCREW SERIES (110V)	24	10.0	N/A	22	2000	20.0	N/A	44	1000	5.0	N/A	11	2000
	36	10.0	N/A	34	2000	20.0	N/A	68	1000	5.0	N/A	17	2000
	48	10.0	N/A	46	2000	20.0	N/A	92	1000	5.0	N/A	23	2000
	72	10.0	N/A	70	2000	20.0	N/A	140	1000	5.0	N/A	35	2000

\* Travel speeds are calculated based on motor and reducer nameplate ratings at 50/60Hz; travel speeds may vary by up to +20% (travel speeds for 1:2 and 2:1 pulley ratios are based on the calculated speeds of the 1:1 pulley ratio)

## SAFETRAC GEN III - INDOOR ACME CURTAIN MACHINES - 220V

**NOTES:**

1. All GEN III SAFETRAC Acme Screw Curtain Machines are standard 220V, 50/60Hz, 1 Phase ONLY.
2. Auto/Manual, Open/Close, and Override local control switches designated by the part number followed by "-SW".
3. Sprocket & chain drive available.
4. INDOOR ONLY - GEN III SAFETRAC Curtain Machines use standard limit switches and include a terminal strip, the units are NOT weather resistant (NOT INTENDED FOR SWINE APPLICATIONS).

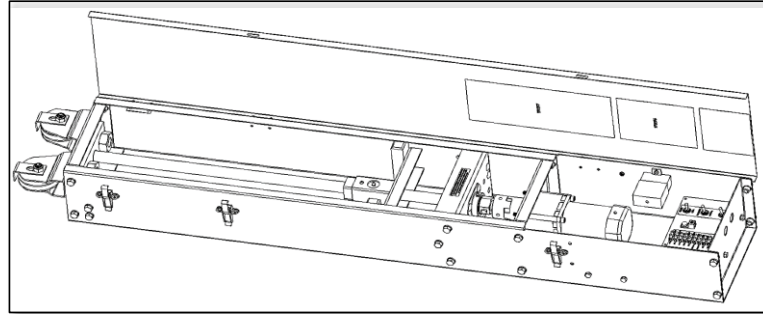

### ACME SCREW CURTAIN MACHINES (220V)

CATALOG #	ITEM DESCRIPTION	SHIP WEIGHT		LIST PRICE
		LBS.	KG.	
970532-24	Curtain Machine 24", Acme Screw, 50/60Hz, 4/4.8 IN/MIN, 25/30 RPM	83.0	37.7	
970532-24-SW	Curtain Machine 24", Acme Screw, 50/60Hz, 4/4.8 IN/MIN, 25/30 RPM with Local Switch	83.0	37.7	
970536-24	With Optional Sprocket & Chain Drive	83.0	37.6	
970536-24-SW	With Optional Sprocket & Chain Drive with Local Switch	83.0	37.6	
970532-36	Curtain Machine 36", Acme Screw, 50/60Hz, 4/4.8 IN/MIN, 25/30 RPM	93.4	42.4	
970532-36-SW	Curtain Machine 36", Acme Screw, 50/60Hz, 4/4.8 IN/MIN, 25/30 RPM with Local Switch	93.4	42.4	
970536-36	With Optional Sprocket & Chain Drive	93.3	42.3	
970536-36-SW	With Optional Sprocket & Chain Drive with Local Switch	93.3	42.3	
970532-48	Curtain Machine 48", Acme Screw, 50/60Hz, 4/4.8 IN/MIN, 25/30 RPM	104.0	47.2	
970532-48-SW	Curtain Machine 48", Acme Screw, 50/60Hz, 4/4.8 IN/MIN, 25/30 RPM with Local Switch	104.0	47.2	
970536-48	With Optional Sprocket & Chain Drive	103.9	47.1	
970536-48-SW	With Optional Sprocket & Chain Drive with Local Switch	103.9	47.1	
970532-72	Curtain Machine 72", Acme Screw, 50/60Hz, 4/4.8 IN/MIN, 25/30 RPM	125.3	56.8	
970532-72-SW	Curtain Machine 72", Acme Screw, 50/60Hz, 4/4.8 IN/MIN, 25/30 RPM with Local Switch	125.3	56.8	
970536-72	With Optional Sprocket & Chain Drive	125.2	56.8	
970536-72-SW	With Optional Sprocket & Chain Drive with Local Switch	125.2	56.8	

## SAFETRAC GEN III - INDOOR ACME CURTAIN MACHINES - 110V

**NOTES:**

1. All GEN III SAFETRAC Acme Screw Curtain Machines are standard 110V 60Hz , 1 Phase ONLY.
2. Auto/Manual, Open/Close, and Override local control switches designated by the part number followed by "-SW".
3. Sprocket & chain drive available.
4. INDOOR ONLY - GEN III SAFETRAC Curtain Machines use standard limit switches and include a terminal strip, the units are NOT weather resistant (NOT INTENDED FOR SWINE APPLICATIONS).

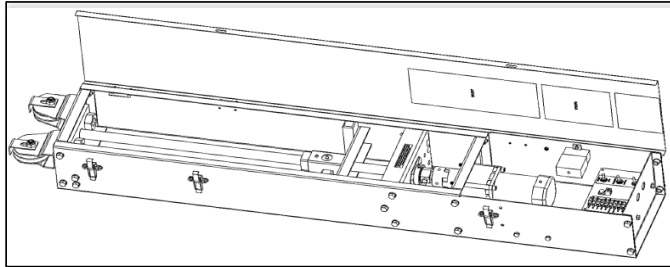

### ACME SCREW CURTAIN MACHINES (110V)

5 inches / minute - 4000 pounds maximum weight		SHIP WEIGHT		
		LBS.	KG.	
CATALOG #	ITEM DESCRIPTION			
970540-24	Curtain Machine 24", Acme Screw, 60Hz, 5 IN/MIN, 30 RPM	83.0	37.7	
970540-24-SW	Curtain Machine 24", Acme Screw, 60Hz, 5 IN/MIN, 30 RPM with Local Switch	83.0	37.7	
970544-24	With Optional Sprocket & Chain Drive	83.0	37.6	
970544-24-SW	With Optional Sprocket & Chain Drive with Local Switch	83.0	37.6	
970540-36	Curtain Machine 36", Acme Screw, 60Hz, 5 IN/MIN, 30 RPM	93.4	42.4	
970540-36-SW	Curtain Machine 36", Acme Screw, 60Hz, 5 IN/MIN, 30 RPM with Local Switch	93.4	42.4	
970544-36	With Optional Sprocket & Chain Drive	93.3	42.3	
970544-36-SW	With Optional Sprocket & Chain Drive with Local Switch	100.0	45.4	
970540-48	Curtain Machine 48", Acme Screw, 60Hz, 5 IN/MIN, 30 RPM	104.0	47.2	
970540-48-SW	Curtain Machine 48", Acme Screw, 60Hz, 5 IN/MIN, 30 RPM with Local Switch	104.0	47.2	
970544-48	With Optional Sprocket & Chain Drive	103.9	47.1	
970544-48-SW	With Optional Sprocket & Chain Drive with Local Switch	103.9	47.1	
970540-72	Curtain Machine 72", Acme Screw, 60Hz, 5 IN/MIN, 30 RPM	125.3	56.8	
970540-72-SW	Curtain Machine 72", Acme Screw, 60Hz, 5 IN/MIN, 30 RPM with Local Switch	125.3	56.8	
970544-72	With Optional Sprocket & Chain Drive	125.2	56.8	
970544-72-SW	With Optional Sprocket & Chain Drive with Local Switch	125.2	56.8	

10 inches / minute - 2000 pounds maximum weight		SHIP WEIGHT		LIST PRICE
		LBS.	KG.	
CATALOG #	ITEM DESCRIPTION			
970561-24	Curtain Machine 24", Acme Screw, 60Hz, 10 IN/MIN, 60 RPM	83.0	37.7	
970561-24-SW	Curtain Machine 24", Acme Screw, 60Hz, 10 IN/MIN, 60 RPM with Local Switch	83.0	37.7	
970562-24	With Optional Sprocket & Chain Drive	83.0	37.6	
970562-24-SW	With Optional Sprocket & Chain Drive with Local Switch	83.0	37.6	
970561-36	Curtain Machine 36", Acme Screw, 60Hz, 10 IN/MIN, 60 RPM	93.4	42.4	
970561-36-SW	Curtain Machine 36", Acme Screw, 60Hz, 10 IN/MIN, 60 RPM with Local Switch	93.4	42.4	
970562-36	With Optional Sprocket & Chain Drive	93.3	42.3	
970562-36-SW	With Optional Sprocket & Chain Drive with Local Switch	93.3	42.3	
970561-48	Curtain Machine 48", Acme Screw, 60Hz, 10 IN/MIN, 60 RPM	104.0	47.2	
970561-48-SW	Curtain Machine 48", Acme Screw, 60Hz, 10 IN/MIN, 60 RPM with Local Switch	104.0	47.2	
970562-48	With Optional Sprocket & Chain Drive	103.9	47.1	
970562-48-SW	With Optional Sprocket & Chain Drive with Local Switch	103.9	47.1	
970561-72	Curtain Machine 72", Acme Screw, 60Hz, 10 IN/MIN, 60 RPM	125.3	56.8	
970561-72-SW	Curtain Machine 72", Acme Screw, 60Hz, 10 IN/MIN, 60 RPM W/Switch	125.3	56.8	
970562-72	With Optional Sprocket & Chain Drive	125.2	56.8	
970562-72-SW	With Optional Sprocket & Chain Drive with Local Switch	125.2	56.8	

## LINEAR ACTUATORS

### VENT, CHIMNEY, INLET ACTUATORS

CATALOG #	ITEM DESCRIPTION	SHIP WEIGHT		LIST PRICE
		LBS.	KG.	
C433	18" Vent Actuator 230VAC 1Ph 50/60Hz 800lb with potentiometer - 14"/min	21.0	9.5	

### ACCESSORIES

CATALOG #	ITEM DESCRIPTION	SHIP WEIGHT		LIST PRICE
		LBS.	KG.	
BE7019	Motor Repair Kit (Actuator) for BE7110	0.0	0.0	
BE7017	Capacitor for BE7110 Motor	0.0	0.0	
ZC427	Potentiometer for C433	0.5	0.2	
750014	Counterweight	10.2	4.6	

## LINEAR ACTUATORS CHART

INLET ACTUATOR SELECTION TABLE			Speed Increases 200% Capacity Decreases 50% Total Travel Increases 200%			Speed Decreases 50% Capacity Remains 100% Total Travel Decreases 50%					
TYPE	CATALOG NUMBER	VAC 1PH	PULLEY RATIO 1:1			PULLEY RATIO 1:2			PULLEY RATIO 2:1		
			TRAVEL IN/MIN	TRAVEL IN	CAPACITY LBS.	TRAVEL IN/MIN	TRAVEL IN	CAPACITY LBS.	TRAVEL IN/MIN	TRAVEL IN	CAPACITY LBS.
INLET ACTUATOR	C433	230	14.0	17	800	28.0	34	400	7.00	9	800

## CURTAIN MACHINE WINCHING

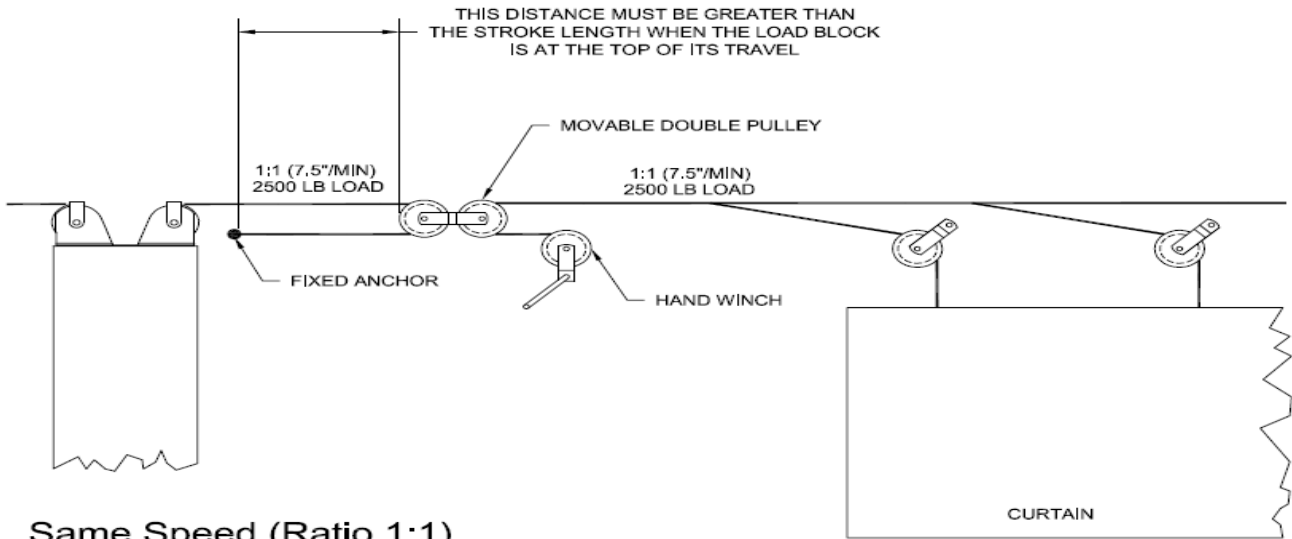

### Same Speed (Ratio 1:1)

12 inches of cable movement at the machine equals 12 inches of cable movement at the curtain

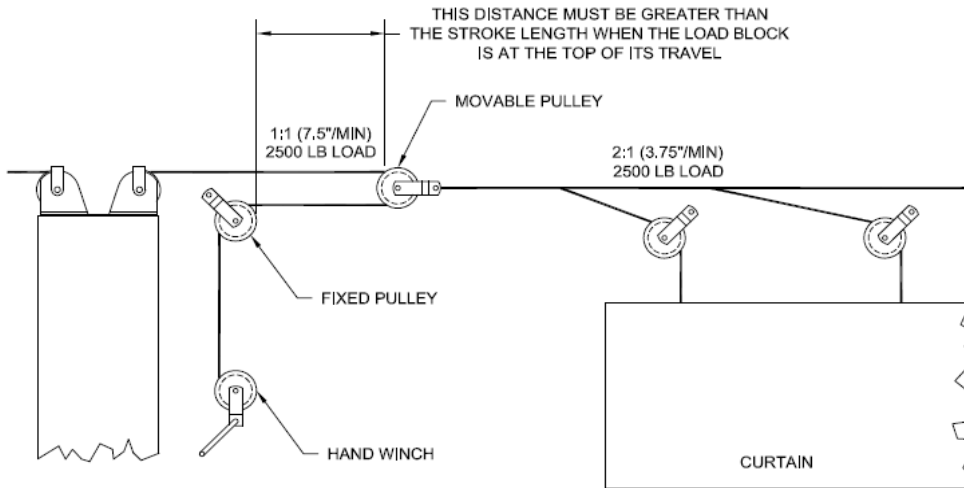

### Speed Down (Ratio 2:1)

12 inches of cable movement at the machine equals 6 inches of cable movement at the curtain

## CURTAIN MACHINE WINCHING

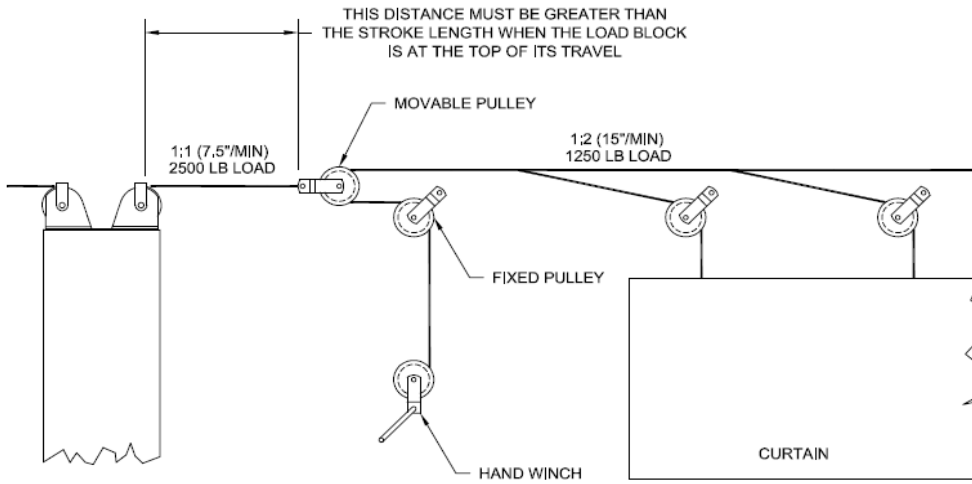

### Speed Up (Ratio 1:2)

12 inches of cable movement at the machine equals 24 inches of cable movement at the curtain

*For more winching accessories please see Section 19 of this catalogue*