

## SECTION 14 FLAT CHAIN FEEDER

### IN THIS CATALOG SECTION

PAGE NUMBER	CONTENTS
14-02	How to Order a Flat Chain Feeder
14-03	Horsepower Recommendations
14-04 thru 14-05	Hoppers & Drive Hoppers - Belt Drive
14-06 thru 14-07	Pulley & Belt Kits
14-08	Motors for V-Belt Drives
14-09	Hoppers & Drives - Direct Drive
14-10	Direct Drive Motors
14-11	Platform Scales - Weigh Hopper
14-12	Corners - Chain - Drop Outlet - Feed Fan Options
14-13	Hen Trough & Accessories
14-14	Pullet Trough & Accessories
14-15	Short Trough Sections
14-16	Wire Grill Profiles & End Caps
14-17 thru 14-18	Regular Profile Grill
14-19	Hi-Pro Profile Grill
14-20	Hi-V Profile Grill
14-21	Straight-line Narrow Loop Chain Feeder
14-22	Manual Feed Troughs

### FLAT CHAIN REPAIRS

SEE REPAIR LISTING & REFERENCE MATERIAL IN SEPARATE CATALOG (Part #: 990232)

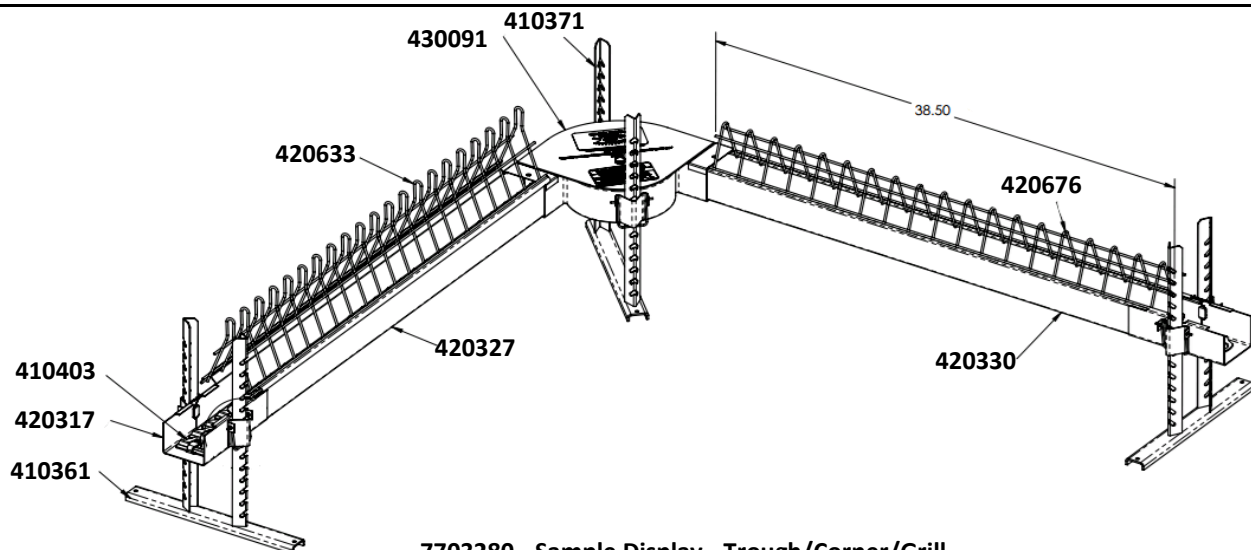

**7703280 - Sample Display - Trough/Corner/Grill**

## HOW TO ORDER A FLAT CHAIN FLOOR FEEDER

After layout of floor chain feeder line or lines are determined, order the following components as needed to complete your flat chain feeder order:

- ▶ Select drive and/or auxillary fill hopper as needed from pages 14-04 & 14-05. Also select extension hoppers if required.
- ▶ **BELT DRIVE:** After checking recommended horsepower requirement on page 14-03, select pulley & belt kit(s) from pages 14-06 & 14-07. Note that 2-way drive hoppers require two motors and two pulley & belt kits.
- ▶ **DIRECT DRIVE:** After checking recommended horsepower requirement on page 14-03, select correct direct drive frame & gearbox unit on page 14-09 and correct motor from page 14-10. If chain feeder is for pullets, also select (1) 421800 per drive.
- ▶ Select farm duty motor(s) from listing on page 14-08.
- ▶ If platform scale & accessories are to be used, select from listing on page 14-11.
- ▶ Select corners from page 14-12. If chain feeder is for pullets, also select 1 corner chick guard per corner.
- ▶ Select proper quantity of chain from page 14-12. Note that chain is only sold in 50' increments. Also select at least one chain breaker tool per house.
- ▶ If required, select number of outlet drops need from page 14-12.
- ▶ Select hen or pullet trough, trough couplers and hangers/stands from listing on pages 14-13 thru 14-14.
- ▶ Select wire grill as needed from listings on pages 14-17 thru 14-20. Note the special production charge for grills on pages 14-17 thru 14-20. Also select grill end caps on page 14-16 (2 per corner + 2 per hopper outlet) when using male exclusion grill.
- ▶ Select wire grill as needed from listings on pages 14-17 thru 14-20. Note the special production charge for grills on pages 14-17 thru 14-20. Also select grill end caps on page 14-16 (2 per corner + 2 per hopper outlet) when using male exclusion grill.
- ▶ Maximum recommended chain speed for cage free layers - 90 fpm
- ▶ Approximate Feed Delivery Rates per minute based on material @ 40 lbs. per cubic foot:

@ 60 fpm	30 - 100 lbs.	13.6 - 45.4 kgs.
@ 90 fpm	45 - 125 lbs.	20.4 - 56.7 kgs.
@ 120 fpm	60 - 150 lbs.	27.2 - 68.0 kgs.

- ▶ Feed delivery rates are approximate only and subject to variables such as feed density and moisture content.

- ▶ Trough space requirement per bird:

Broilers	2 - 3"	(5.1 - 7.6 cm)
Pullets	4.5 - 6"	(11.4 - 15.2 cm)
Broiler Breeders	4.5 - 6"	(11.4 - 15.2 cm)

- ▶ Each linear foot of trough equals 24" (61cm) of trough space.
- ▶ For assistance in figuring flat chain cage feeding, please contact your sales representative.



## HORSEPOWER RECOMMENDATIONS FOR FLAT CHAIN FEEDER

### BELT DRIVE - 1 Drive per Chain Loop

CHAIN SPEED PER MINUTE	TOTAL CHAIN LENGTH (up to but not including)									
	To 400' 122m	500' 152m	600' 183m	700' 213m	800' 244m	900' 274m	1000' 305m	1100' 335m	1200' 366m	
20-40 Feet 6-12 Meters	.75 hp		1.00 hp		1.50 hp					
60 Feet 18 Meters	1.00 hp		1.50 hp			2.00 hp				
80-90 Feet 24-27 Meters	1.00 hp	1.50 hp		2.00 hp						
120 Feet 36 Meters	3.00 hp**									

### BELT DRIVE, 2 Drives per Chain Loop

CHAIN SPEED PER MINUTE	TOTAL CHAIN LENGTH (up to but not including)									
	To 400' 122m	500' 152m	600' 183m	700' 213m	800' 244m	900' 274m	1000' 305m	1100' 335m	1200' 366m	
20-40 Feet 6-12 Meters	.75 hp			1.00 hp			1.50 hp			
60 Feet 18 Meters	.75 hp		1.00 hp			1.50 hp		2.00 hp		
80-90 Feet 24-27 Meters	.75 hp	1.00 hp		1.50 hp			2.00 hp			
120 Feet 36 Meters	3.00 hp**									

**Note: Table lists HP per drive. Space drives equidistant from each other in the loop.**

### DIRECT DRIVE - 1 Drive per Chain Loop

CHAIN SPEED PER MINUTE	TOTAL CHAIN LENGTH (up to but not including)									
	To 400' 122m	500' 152m	600' 183m	700' 213m	800' 244m	900' 274m	1000' 305m	1100' 335m	1200' 366m	
60 Feet 18 Meters	1.00 HP		1.50 hp			2.00 hp				
90 Feet 27 Meters	1.00 hp	1.50 hp		2.00 hp						
120 Feet 36 Meters	2.00 hp									

### DIRECT DRIVE, 2 Drives per Chain Loop

CHAIN SPEED PER MINUTE	TOTAL CHAIN LENGTH (up to but not including)									
	To 400' 122m	500' 152m	600' 183m	700' 213m	800' 244m	900' 274m	1000' 305m	1100' 335m	1200' 366m	
60 Feet 18 Meters	.75 HP		1.00 hp			1.50 hp		2.00 hp		
90 Feet 27 Meters	.75 hp	1.00 hp		1.50 hp			2.00 hp			
120 Feet 36 Meters	1.50 hp			2.00 hp						

**Note: Table lists HP per drive. Space drives equidistant from each other in the loop.**

\*\* 3 HP motor (high rpm) recommended for all 120fpm circuits with belt drive.

## BELT DRIVES

### SUSPENDED MODEL HOPPERS BELT DRIVE LESS MOTOR(S)

CATALOG NUMBER	ITEM DESCRIPTION	SHIP WEIGHT		LIST PRICE
		LBS.	KGS.	
420700	1-LINE SUSPENDED MODEL DRIVE HOPPER - 60 lb. (27kg) hopper capacity - Extension hopper available below - Select pulley & belt kit from Chart A on page 14-06	149.0	67.6	
420820	1-LINE SUSPENDED MODEL AUXILARY FILL HOPPER - 60 lb. (27kg) hopper capacity - Extension hopper available below - Pulley & belt kit not required	59.0	26.8	
410100	2-LINE 1-WAY SUSPENDED MODEL DRIVE HOPPER - 60 lb. (27kg) hopper capacity - Extension hopper available below - Select pulley & belt kit from Chart C on page 14-07	198.0	89.8	
420780	2-LINE SUSPENDED MODEL AUXILARY FILL HOPPER - 60 lb. (27kg) hopper capacity - Extension hopper available below - Pulley & belt kit not required	61.0	27.7	
410150	2-LINE 2-WAY SUSPENDED MODEL DRIVE HOPPER - 60 lb. (27kg) hopper capacity - Extension hopper available below - Select two pulley & belt kits from Chart C on page 14-07 - Select two motors from page 14-08	287.0	130.2	
410600	4-LINE 2-WAY SUSPENDED MODEL DRIVE HOPPER - 100 lb. (45kg) hopper capacity - Extension hopper available below - Select two pulley & belt kits from Chart C on page 14-07 - Select two motors from page 14-08	385.0	174.6	
420950	4-LINE SUSPENDED AUXILLARY HOPPER - No Top Cover - 60 lb. (27kg) hopper capacity - Can be used with I line extention hoppers	53.0	24.0	
420900	Low Profile Extension Hopper with Top Cover for 1-Line Hoppers - 155 lb. (70kg) capacity - Hopper is 18.5" tall	34.0	15.4	
420551	Extension Hopper With Top Cover for 1-Line Hoppers - 220 lb. (100kg) capacity	35.0	15.9	
410624	Extension Hopper With Top Cover for 2-Line Hoppers - 220 lb. (100kg) capacity	33.9	15.4	
410625	Extension Hopper With Top Cover for 4-Line Hoppers - 220 lb. (100kg) capacity	36.1	16.4	
411040	Lid Kit for Suspension Base Hopper	8.6	3.9	
421970	Flat Chain Large Cap Hopper 350 Lb Capacity	61.5	27.9	
420880	Adjustable Hopper Legs - Carton of 4 Legs	21.5	9.7	

**NOTE:** Chain speeds of 60-90-120 fpm are available for the above units - select pulley & belt kit(s) from pages 14-06 & 14-07.

**NOTE:** Place drives 36" from corners to maximize component life.

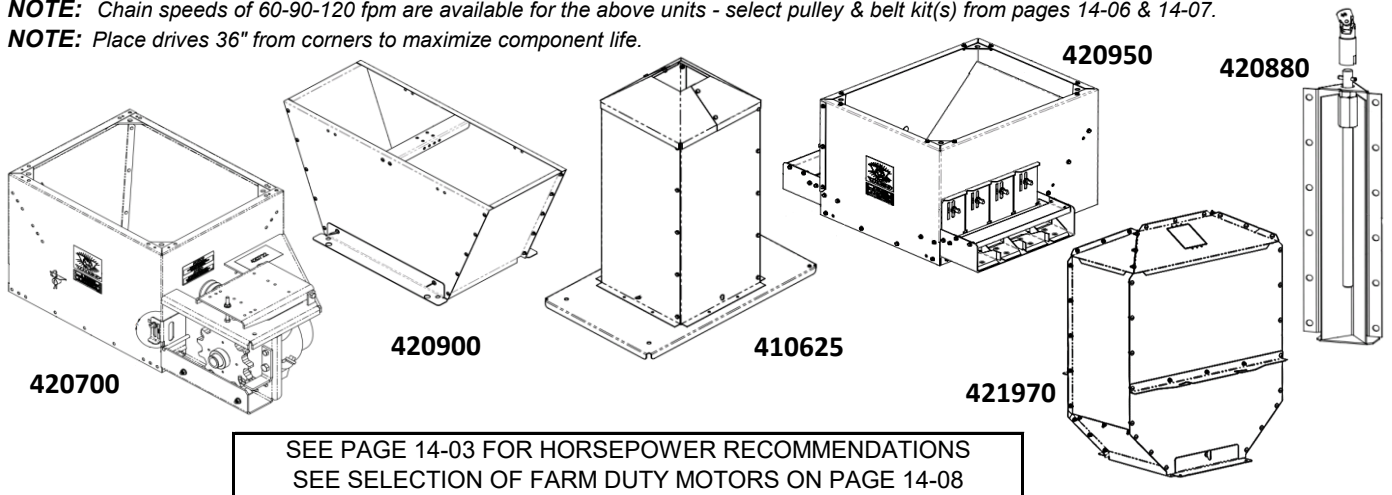

SEE PAGE 14-03 FOR HORSEPOWER RECOMMENDATIONS  
 SEE SELECTION OF FARM DUTY MOTORS ON PAGE 14-08

## BELT DRIVES

<b>CORNER DRIVE HOPPERS BELT DRIVE LESS MOTOR</b>		SHIP WEIGHT		LIST PRICE
		LBS.	KGS.	
CATALOG NUMBER	ITEM DESCRIPTION			
410031	1-LINE CORNER MODEL DRIVE HOPPER - Select pulley & belt kit from Chart D on page 14-07	135.0	61.2	
410030	For chain speed of 20-40 fpm with the appropriate pulley & belt kit(s).	135.0	61.2	

**NOTE:** Chain speeds of 60-90-120 fpm are available for the above units - select pulley & belt kit(s) from pages 14-06 & 14-07.

<b>FLOOR MODEL DRIVE HOPPERS BELT DRIVE LESS MOTOR(S)</b>		SHIP WEIGHT		LIST PRICE
		LBS.	KGS.	
CATALOG NUMBER	ITEM DESCRIPTION			
410270	1-LINE FLOOR MODEL DRIVE HOPPER - 400 lb. (182 kg.) hopper capacity - Select pulley & belt kit from Chart B on page 14-06	214.0	97.1	
420790	1-LINE FLOOR MODEL AUXILARY FILL HOPPER - 400 lb. (182 kg.) hopper capacity - Pulley & belt kit not required	120.0	54.4	
410200	2-LINE 1-WAY FLOOR MODEL DRIVE HOPPER - 400 lb. (182 kg.) hopper capacity - Select pulley & belt kit from Chart C on page 14-07	275.0	124.7	
410250	2-LINE 2-WAY FLOOR MODEL DRIVE HOPPER - 400 lb. (182 kg.) hopper capacity - Select two pulley & belt kits from Chart C on page 14-07 - Select two motors from page 14-08	456.0	206.8	
410650	4-LINE 2-WAY FLOOR MODEL DRIVE HOPPER - 400 lb. (182 kg.) hopper capacity - Select two pulley & belt kits from Chart C on page 14-07 - Select two motors from page 14-08	462.5	209.8	
411027	Cover for 400 pound (182kg) hopper	19.0	8.6	

**NOTE:**

Chain speeds of 60-90-120 fpm are available for the above units - select pulley & belt kit(s) from pages 14-06 & 14-07.

**Note:** Place drives 36" from corners to maximize component life.

SEE PAGE 14-03 FOR HORSEPOWER RECOMMENDATIONS  
 SEE SELECTION OF FARM DUTY MOTORS ON PAGE 14-08

<b>HOPPER LEVEL CONTROL</b>		SHIP WEIGHT		LIST PRICE
		LBS.	KG.	
CATALOG #	ITEM DESCRIPTION			
720097	Adjustable-Mechanical hopper level control. 220V, 20amp, 1-3phase, 50-60hz	4.8	2.2	

## PULLEY & BELT KITS

### CHART A

#### **PULLEY & BELT KITS**

#### **FOR 1-LINE SUSPENDED MODEL DRIVE HOPPERS**

CATALOG NUMBER	CHAIN SPEED		ELECTRIC INFO	MOTOR SHAFT DIAMETER	SHIP WEIGHT		LIST PRICE
	FEET/MINUTE	METERS/MINUTE			LBS.	KGS.	
420740	60	18	60 Hz	5/8"	2.0	0.9	
420748	60	18	60 Hz	7/8"	1.9	0.9	
420741	60	18	50 Hz	5/8"	2.7	1.2	
420749	60	18	50 Hz	7/8"	4.5	2.0	
420742	90	27	60 Hz	5/8"	4.0	1.8	
420759	90	27	60 Hz	7/8"	0.0	0.0	
420743	90	27	50 Hz	5/8"	4.0	1.8	
420765	90	27	50 Hz	7/8"	0.0	0.0	
420744	120	36	60 Hz	5/8"	4.0	1.8	
420748	120	36	60 Hz	7/8"	1.9	0.9	
420745	120	36	50 Hz	5/8"	4.0	1.8	
420749	120	36	50 Hz	7/8"	4.5	2.0	
420746	25-40	7.5-12	60 Hz	5/8"	4.0	1.8	
420747	20-30	6-9	50 Hz	5/8"		0.0	

### CHART B

#### **PULLEY & BELT KITS**

#### **FOR 1-LINE FLOOR MODEL DRIVE HOPPERS**

CATALOG NUMBER	CHAIN SPEED		ELECTRIC INFO	MOTOR SHAFT DIAMETER	SHIP WEIGHT		LIST PRICE
	FEET/MINUTE	METERS/MINUTE			LBS.	KGS.	
415070	60	18	60 Hz	5/8"	3.7	1.7	
415103	60	18	60 Hz	7/8"	3.6	1.6	CALL
415082	60	18	50 Hz	5/8"	6.0	2.7	
415146	60	18	50 Hz	7/8"		0.0	
415097	80	24	60 Hz	5/8"	7.0	3.2	CALL
415113	80	24	60 Hz	7/8"	4.0	1.8	
415147	90	27	60 Hz	5/8"	9.0	4.1	
415134	90	27	60 Hz	7/8"	9.0	4.1	
415084	90	27	50 Hz	5/8"	5.2	2.4	
415153	90	27	50 Hz	7/8"		0.0	
415074	120	36	60 Hz	5/8"	3.3	1.5	
415118	120	36	60 Hz	7/8"	3.2	1.5	
415086	120	36	50 Hz	5/8"	3.9	1.8	
415132	120	36	50 Hz	7/8"	3.7	1.7	
415076	25-40	7.5-12	60 Hz	5/8"	15.0	6.8	
415088	40	12	50 Hz	5/8"	16.0	7.3	
415094	25	7.5	50 Hz	5/8"	17.0	7.7	

REFER TO MOTOR LISTING ON PAGE 14-08 FOR SHAFT SIZE OF SELECTED MOTOR

## PULLEY & BELT KITS

### **CHART C**

#### **PULLEY & BELT KITS**

#### **FOR 2-LINE & 4-LINE SUSPENDED & FLOOR MODEL DRIVE HOPPERS**

CATALOG NUMBER	CHAIN SPEED		ELECTRIC INFO	MOTOR SHAFT DIAMETER	SHIP WEIGHT		LIST PRICE
	FEET/MINUTE	METERS/MINUTE			LBS.	KGS.	
415071	60	18	60 Hz	5/8"	3.7	1.7	
415624	60	18	60 Hz	7/8"	3.2	1.5	
415083	60	18	50 Hz	5/8"	4.0	1.8	
415151	60	18	50 Hz	7/8"			
415107	80	24	60 Hz	5/8"	4.0	1.8	CALL
415114	80	24	60 Hz	7/8"	4.0	1.8	
415073	90	27	60 Hz	5/8"	4.4	2.0	
415126	90	27	60 Hz	7/8"	4.0	1.8	
415085	90	27	50 Hz	5/8"	4.7	2.1	
415161	90	27	50 Hz	7/8"			
415075	120	36	60 Hz	5/8"	3.3	1.5	
415162	120	36	60 Hz	7/8"	3.2	1.4	
415087	120	36	50 Hz	5/8"	4.0	1.8	
415121	120	36	50 Hz	7/8"	4.0	1.8	
415077	25-40	7.5-12	60 Hz	5/8"	4.0	1.8	
415089	40	12	50 Hz	5/8"	4.0	1.8	
415095	25	7.5	50 Hz	5/8"	4.0	1.8	

### **CHART D**

#### **PULLEY & BELT KITS**

#### **FOR INDEPENDENT, STRAIGHT-THRU AND CORNER DRIVES**

CATALOG NUMBER	CHAIN SPEED		ELECTRIC INFO	MOTOR SHAFT DIAMETER	SHIP WEIGHT		LIST PRICE
	FEET/MINUTE	METERS/MINUTE			LBS.	KGS.	
415078	60	18	60 Hz	5/8"	4.0	1.8	
415164	60	18	50 Hz	5/8"			
415079	90	27	60 Hz	5/8"	4.0	1.8	
415091	90	27	50 Hz	5/8"	4.0	1.8	
415080	120	36	60 Hz	5/8"	4.0	1.8	
415092	120	36	50 Hz	5/8"	4.0	1.8	
415081	25-40	7.5-12	60 Hz	5/8"	4.0	1.8	
415093	40	12	50 Hz	5/8"	4.0	1.8	
415096	25	7.5	50 Hz	5/8"	4.0	1.8	

REFER TO MOTOR LISTING ON PAGE 14-08 FOR SHAFT SIZE OF SELECTED MOTOR

## FARM DUTY MOTORS - FOR BELT DRIVE UNITS

### 60HZ - 1 PHASE

CATALOG NUMBER	HORSE-POWER	HZ	1 OR 3 PHASE	MOTOR VOLTAGE	MOTOR RPM	ENCLOSURE	NEMA FRAME	SHAFT SIZE	THERMO PROTECT	SHIP WEIGHT	LIST PRICE
920402	.75	60	1	115/230	1725	TEFC	56	5/8"	Manual	27.0	
920403	1.0	60	1	115/230	1725	TEFC	56	5/8"	Manual	34.0	
920404	1.5	60	1	115/230	1725	TEFC	56H	5/8"	Manual	44.0	
920405	2.0	60	1	115/230	1725	TEFC	56HZ	7/8"	Manual	49.3	
410129	3.0	60	1	230	3450	Drip Proof	56Y	5/8"	Manual	39.6	

### 60HZ - 3 PHASE

CATALOG NUMBER	HORSE-POWER	HZ	1 OR 3 PHASE	MOTOR VOLTAGE	MOTOR RPM	ENCLOSURE	NEMA FRAME	SHAFT SIZE	THERMO PROTECT	SHIP WEIGHT	LIST PRICE
920442	.75	60	3	230/460	1725	TEFC	56	5/8"	Manual	24.0	
920443	1.0	60	3	230/460	1745	TEFC	56	5/8"	Manual	26.0	
920444	1.5	60	3	230/460	1745	TEFC	56H	5/8"	Manual	30.0	
920445	2.0	60	3	230/460	1745	TEFC	145T	7/8"	None	35.0	
920419	3.0	60	3	208-230/460	3450	TEFC	145T	7/8"	None	41.2	

### 50HZ - 1 PHASE

CATALOG NUMBER	HORSE-POWER	HZ	1 OR 3 PHASE	MOTOR VOLTAGE	MOTOR RPM	ENCLOSURE	NEMA FRAME	SHAFT SIZE	THERMO PROTECT	SHIP WEIGHT	LIST PRICE
920552	.75	50	1	110/220	1425	TEFC	56	5/8"	None	23.0	
920553	1.0	50	1	110/220	1425	TEFC	56H	5/8"	None	25.0	
920554	1.5	50	1	110/220	1500	TEFC	56H	5/8"	Manual	30.0	
920555	2.0	50	1	220	1500	TEFC	182T	1-1/8"	Manual	85.0	
410675	3.0	50	1	220	3000	IP22	56H	5/8"	None	47.0	

### 50HZ - 3 PHASE

CATALOG NUMBER	HORSE-POWER	HZ	1 OR 3 PHASE	MOTOR VOLTAGE	MOTOR RPM	ENCLOSURE	NEMA FRAME	SHAFT SIZE	THERMO PROTECT	SHIP WEIGHT	LIST PRICE
920562	.75	50/60	3	208-220/440 or 190/380V	1725/1800	TEFC	56	5/8"	None	24.0	
920563	1.0	50/60	3	208-220/440 or 190/380V	1725/1800	TEFC	56H	5/8"	None	30.0	
920564	1.5	50/60	3	208-220/440 or 190/380V	1725/1800	TEFC	56H	5/8"	None	34.0	
920565	2.0	50/60	3	208-220/440 or 190/380V	1725/1800	TEFC	56C	5/8"	None	30.0	
920419	3.0	50/60	3	208-220/440 or 190/380V	2875	TEFC	145T	7/8"	None	41.2	

SEE CATALOG SECTION 20 FOR A COMPLETE LISTING OF ALL ELECTRIC MOTORS

## INDEPENDENT DIRECT DRIVES

### AUXILIARY FILL HOPPERS FOR USE WITH INDEPENDENT DIRECT DRIVE

CATALOG NUMBER	ITEM DESCRIPTION	SHIP WEIGHT		LIST PRICE
		LBS.	KGS.	
420820	1-LINE SUSPENDED MODEL AUXILIARY FILL HOPPER - 60 lb. (27kg) hopper capacity - Galvanized construction - Extension hopper available below	59.0	26.8	
420790	1-LINE FLOOR MODEL AUXILIARY FILL HOPPER - 400 lb. (182 kg.) hopper capacity - Extension not available	120.0	54.4	
420780	2-LINE SUSPENDED MODEL AUXILIARY FILL HOPPER - 60 lb. (27kg) hopper capacity - Extension hopper available below	61.0	27.7	
420551	Extension Hopper With Top Cover for 1-Line Hoppers - 220 lb. (100kg) capacity	35.0	15.9	
410624	Extension Hopper With Top Cover for 2-Line Fill Hopper - 220 lb. (100kg) capacity - Includes top cover	33.9	15.4	
420900	Low Profile Extension Hopper with Top Cover for 1-Line Hoppers - 155 lb. (70kg) capacity - Hopper is 18.5" tall	34.0	15.4	
411040	Lid Kit for Suspension Base Hopper	8.6	3.9	
420880	Adjustable Hopper Legs - Carton of 4 Legs	21.5	9.7	
421800	Direct Drive Guard kit, for use when using Pullet Trough	1.7	0.8	

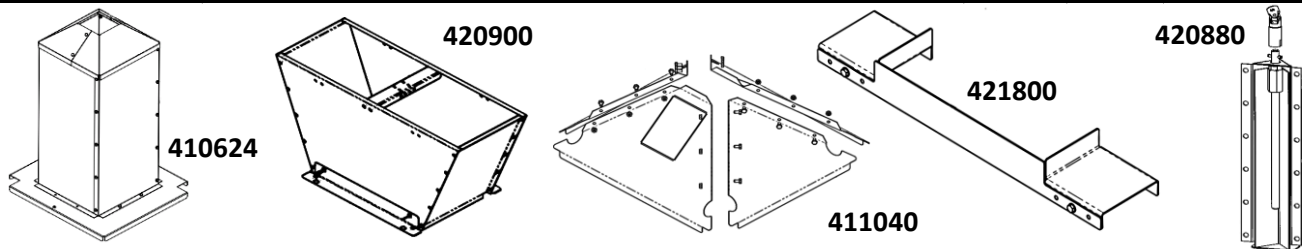

#### TO ORDER A COMPLETE INDEPENDENT DIRECT DRIVE UNIT WITH MOTOR

1. Determine chain speed desired and horsepower requirement (see chart on page 14-03).
2. Order correct frame & gearbox unit from listing below, after determining chain speed & horsepower requirement.
3. Order correct motor from page 14-10.

#### INDEPENDENT DIRECT DRIVE FRAME & GEARBOX UNITS (MOTOR NOT INCLUDED)

CATALOG #	ITEM DESCRIPTION	SHIP WEIGHT		LIST PRICE
		LBS.	KG.	
420250	Frame & Gearbox Assy - 60 or 120fpm - Less Than 1.5	86.8	39.4	
420252	Frame & Gearbox Assy - 60 or 120fpm - 1.5 - 2.0 HP	108.8	49.4	
420251	Frame & Gearbox Assy - 90fpm - Less Than 1.5 HP	91.8	41.6	
420253	Frame & Gearbox Assy - 90fpm - 1.5 - 2.0 HP	108.8	49.4	

*If using Direct Drive frame and gearbox with pullet trough, order (1) 421800.*

#### INDEPENDENT DIRECT DRIVE FRAME & GEARBOX UNITS with Motor

420970	Compact Drive 120fpm, 3HP(2.2kW), 220v, 60Hz,1PH	86.8	39.4	
420971	Compact Drive 120fpm, 3HP(2.2kW), 415-460v, 50Hz,3PH	86.8	39.4	
420972	Compact Drive 120fpm, 3HP(2.2kW), 220v, 50Hz,1PH	86.8	39.4	
420973	Compact Drive 120fpm, 3HP(2.2kW), 208-230/460v, 60Hz,3PH	86.8	39.4	
420974	Compact Drive 120fpm, 3HP(2.2kW), 190-380v, 50Hz,3PH	86.8	39.4	
420940	Compact Direct Drive Floor Stand	8.3	3.8	

## INDEPENDENT DIRECT DRIVES

### MOTORS FOR 60 FPM CHAIN SPEED

CATALOG NUMBER	ITEM DESCRIPTION	SHIP WEIGHT		LIST PRICE
		LBS.	KGS.	
420248	.75 HP - 60 HZ - 115/208-230 -- Single Phase - 1745 RPM	28.8	13.1	
611032	1.0 HP - 60 HZ - 115/208-230v - Single Phase - 1725 RPM	32.0	14.6	
420259	1.5 HP - 60 HZ - 115/208-230v - Single Phase - 1800 RPM	39.0	17.7	
775064	2.0 HP - 60 HZ - 115/208-230v - Single Phase - 1730 RPM	49.6	22.5	
420255	.75 HP - 60 HZ - 208/230v - 3-Phase - 1725 RPM	11.8	5.4	
612146	1.0 HP - 60 HZ - 190/380-230/460v - 3-Phase - 1760 RPM	36.4	16.6	
980109	1.5 HP - 60 HZ - 190/380v - 3-Phase - 1750 RPM	41.1	18.7	
980109	1.5 HP - 50 HZ - 208-230/460v - 3-Phase - 1450 RPM	41.1	18.7	
420285	2.0 HP - 60 HZ - 190-380v - 3-Phase - 1750 RPM	45.6	20.7	
420285	2.0 HP - 50 HZ - 208-230/460v - 3-Phase - 1430 RPM	45.6	20.7	
420263	.75 HP - 50 HZ - 110/220v - Single Phase - 1500 RPM	14.3	6.5	
420264	1.0 HP - 50 HZ - 110/220v - Single Phase - 1500 RPM	14.9	6.8	
420265	1.5 HP - 50 HZ - 110/220v - Single Phase - 1500 RPM	16.9	7.7	
420268	.75 HP - 50 HZ - 220/380v - 3-Phase - 1500 RPM	12.3	5.6	
420269	1.0 HP - 50 HZ - 220/380v - 3-Phase - 1500 RPM	27.7	12.6	

### MOTORS FOR 90 OR 120 FPM CHAIN SPEED

CATALOG NUMBER	ITEM DESCRIPTION	SHIP WEIGHT		LIST PRICE
		LBS.	KGS.	
420246	.75 HP - 60 HZ - 115/208-230v - Single Phase - 3460 RPM	0.0	0.0	
420245	1.0 HP - 60 HZ - 115/208-230v - Single Phase - 3460 RPM	30.1	13.7	
420260	1.5 HP - 60 HZ - 115/208-230v - Single Phase - 3600 RPM	34.5	15.7	
420283	2.0 HP - 60 HZ - 115/208-230v - Single Phase - 3460 RPM	42.0	19.1	
420256	.75 HP - 60 HZ - 208-230/460v - 3-Phase - 3450 RPM	11.8	5.4	
420258	1.0 HP - 60 HZ - 208-230/460v - 3-Phase - 3600 RPM	11.8	5.4	
420262	1.5 HP - 60 HZ - 208-230/460v - 3-Phase - 3600 RPM	32.0	14.6	
420262	1.5 HP - 50 HZ - 190/380v - 3-Phase - 3000 RPM	32.0	14.6	
420284	2.0 HP - 60 HZ - 230/460v - 3-Phase - 3600 RPM	43.0	19.6	
	<b>NOT AVAILABLE</b> - 50HZ Single Phase Motors 2850 RPM USE 60 FPM CHAIN SPEED	NOT AVAILABLE		
420297	.75 HP - 50 HZ - 220/380v - 3-Phase - 3000 RPM	12.0	5.5	
420298	1.0 HP - 50 HZ - 220/380v - 3-Phase - 3000 RPM	12.0	5.5	
420262	1.5 HP - 60 HZ - 208-230/460v - 3-Phase - 3600 RPM	32.0	14.6	
420262	1.5 HP - 50 HZ - 190/380v - 3-Phase - 3000 RPM	32.0	14.6	

## FLAT CHAIN SYSTEM COMPONENTS

### PLATFORM SCALE ACCESSORIES

CATALOG #	ITEM DESCRIPTION	SHIP WEIGHT		LIST PRICE
		LBS.	KG.	
415449	Platform Scale Control With Magnetic Cutoff Controls Fill System - 240v 60/50hz	10.0	4.5	
415488	Platform Scale Control (CC-HR Control Box) Controls Fill System - 440v/50hz/3phase	11.0	5.0	
415526	Set of Extension Legs for Platform Scale Lifts Scale Off Floor for Easy Cleaning	0.0	0.0	
415448	Mount Rail Bridge Kit - for Suspended Model Hoppers	30.0	13.6	
415525	Mount Rail Bridge Kit - for Floor Model Hoppers	14.5	6.6	
421990	Adapter Plate for Flat Chain Hopper and Spinks Scale	9.0	4.1	

### WEIGH HOPPER & EXTENSION

CATALOG #	ITEM DESCRIPTION	SHIP WEIGHT		LIST PRICE
		LBS.	KG.	
410509	1,400 lb. (635 kg.) Galvanized Weigh Hopper Includes Legs and Slide Gate	165.0	74.8	
411033	Weigh Hopper Extension Leg 4 needed for 410509 Weigh Hopper	1.8	0.8	
410510	400 lb. (180 kg.) Galvanized Extension for 410509 Weigh Hopper	30.0	13.6	
415528	Lower Boot / Unloader Adapter Allows for Attachment of a Lower Boot/Unloader Directly to the 410509 Hopper (no plastic upper transition required)	25.0	11.3	

## FLAT CHAIN SYSTEM COMPONENTS

### CORNERS & ACCESSORIES

CATALOG #	ITEM DESCRIPTION	SHIP WEIGHT		LIST PRICE
		LBS.	KG.	
430091	Universal Corner, Suspended or Floor (without Floor Stand)	13.3	6.0	
430091-Q228	Universal Corner, Suspended or Floor (without Floor Stand) - Skid Qty	3,100.0	1,406.2	
480300	Universal Corner with Oiler, Suspended or Floor (without Floor Stand)	13.3	6.0	
610893	Corner Oil Cup	0.1	0.0	
611727	Corner Oil Cup Wick	0.0	0.0	
410028	Floor Corner - with Painted Floor Stand	15.0	6.8	
410371	Floor Stand Only for Corner - Painted	2.2	1.0	
411048	Floor Stand Only for Corner - Stainless Steel	2.4	1.1	
410597	VAL-CO Corner Chick Guard for Pullet Trough*	0.4	0.2	
410598	VAL-CO Corner Chick Guard for Hen Trough*	0.5	0.2	

\* Set corner chick guard height high enough to prevent feed build-up and low enough to not allow a chick to get under.

Helps to minimize the chances of chicks getting entangled in feed corners, but cannot prevent chicks from injury if chain is running while birds have access to the chain feeding system.

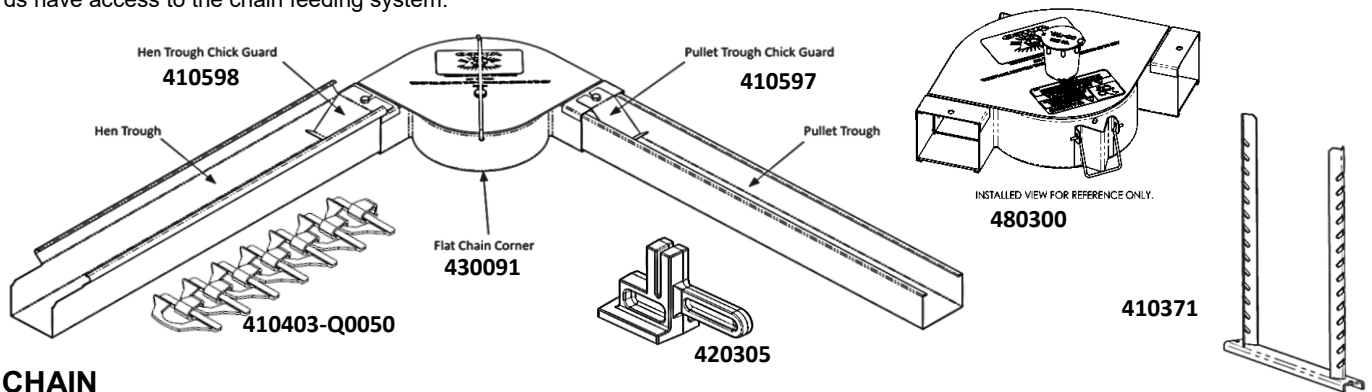

### CHAIN

410403-Q0050	2.75" Flat Chain - (50) Foot	35.9	16.3	
410403-Q5400	2.75" Flat Chain - Skid Quantity of 5400 ft	3,880.0	1,760.0	
410403-Q59400	2.75" Flat Chain - Truckload Quantity of 59,400 ft	42,680.0	19,359.6	
420305	Flat Chain Breaker	3.4	1.5	

### PAN FEEDER OPTIONS FOR ATTACHMENT TO TROUGH

455180	Hen Feeder for Chain Trough attachment. Includes all hardware.	3.8	1.7	
455160	PXR Rooster Feeder - 8 Spoke Wire Grill - 0 to 3 lb. (1.36kg) adjustable capacity; slide shut off; designed to mount on chain feeder with all necessary hardware. <b>Includes 450594 feed restrictor.</b>	4.8	2.2	

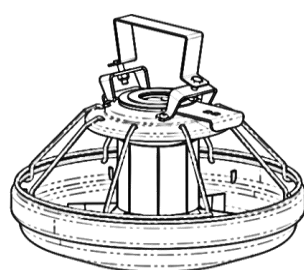

455180

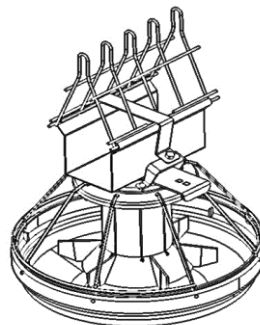

455160

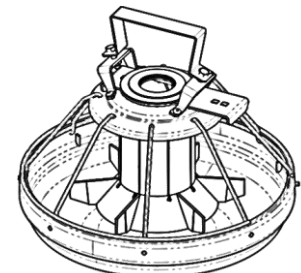

## HEN TROUGH & ACCESSORIES

### HEN TROUGH (MEDIUM WIDE) - COUPLERS - SUPPORT

CATALOG #	ITEM DESCRIPTION	SHIP WEIGHT		LIST PRICE
		LBS.	KG.	
410300	10' Hen Trough	18.0	8.2	
410308	12' Hen Trough	21.3	9.7	
410329	8" Hen Trough Coupler - With Hanger	1.8	0.8	
410328	8" Hen Trough Coupler - Less Hanger	1.5	0.7	
410465	Wire Hanger for Hen Trough Coupler	0.2	0.1	
410488	Hi-Pro Wire Hanger for Hen Trough	0.2	0.1	
630297	1 Piece Hen Trough Hanger Bracket with 3 Perch Tube Holes	3.4	1.6	
630291	2 Piece Hen Trough Hanger Kit with 1.25" Dia. Hole for 1.163" Perch Pipe	0.9	0.4	
630295	Floor Trough Support with 3 Perch Holes (1.375" Holes for Perch Pipe)	5.1	2.31	
630270	Floor Trough Support with 3 Perch Holes - Sloped Floors	6.9	3.13	
411036	Heavy Duty "J" Hanger	0.7	0.3	
410070	Trough Clean-Out Cover - includes 4 Wing Nuts	1.7	0.8	
610544	Trough Clean-Out Cover - includes 2 Wing Nuts	0.7	0.3	

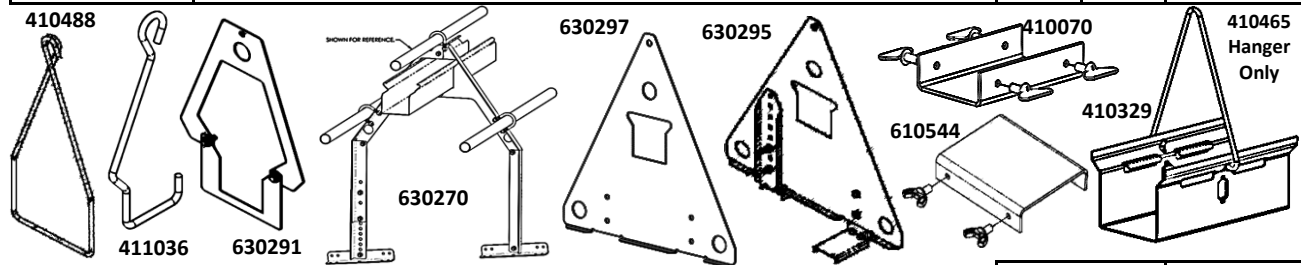

### FLOOR TROUGH COUPLERS

CATALOG #	ITEM DESCRIPTION	SHIP WEIGHT		LIST PRICE
		LBS.	KG.	
420318	8" Floor Trough Coupler with Painted Floor Stand	3.9	1.8	
420320	8" Floor Trough Coupler Less Stand	2.9	1.3	
410361	Floor Stand Only for Floor Trough Coupler - Painted	2.3	1.0	
411048	Floor Stand Only for Floor Trough Coupler - Stainless Steel	2.4	1.1	
410664	Floor Stand Only for Floor Trough Coupler - Plastic*	0.7	0.3	

\* Not for use in Perching Applications

### HEN PERCH SUPPORT ACCESSORIES

CATALOG #	ITEM DESCRIPTION	SHIP WEIGHT		LIST PRICE
		LBS.	KG.	
630295	Floor Trough Support with 3 Perch Holes (1.375" Holes for Perch Pipe)	5.1	2.31	
VC316	1.163" Tube 10' long with coupler (includes VC318 tube & VC317 coupler)	4.4	1.98	
631233	End Plug Tube Cap	0.0	0.00	
630429	Perch Hanger Hen Trough 1.163" Tube	0.8	0.34	
630430	Perch Support Hen Trough 1.163" Tube	0.2	0.08	
630431	Strap for 1.163" Tube	0.0	0.01	
690142	Screw for Strap (2 required per strap)	0.0	0.00	
631865	1.25" OD x 20' 14GA Pipe with Holes	17.8	8.07	
631811	1.25" Dia Pipe Coupler Kit	0.7	0.33	
631812	1.25" OD pipe Plug	0.0	0.01	

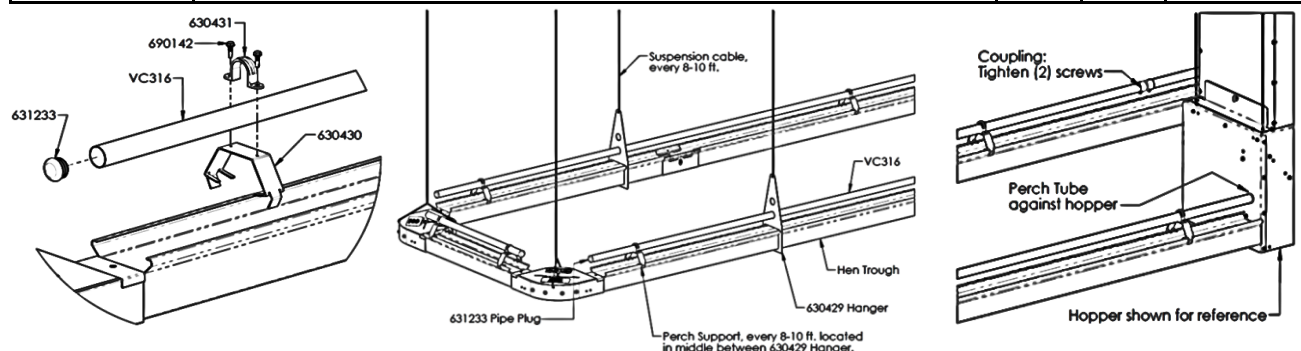

## PULLET TROUGH & ACCESSORIES

### PULLET TROUGH (REGULAR) - COUPLERS - HANGERS

CATALOG #	ITEM DESCRIPTION	SHIP WEIGHT		LIST PRICE
		LBS.	KG.	
410310	10' Pullet Trough	15.4	7.0	
410322	12' Pullet Trough	18.5	8.4	
410378	8" Pullet Trough Coupler - With Hanger	1.9	0.9	
410377	8" Pullet Trough Coupler - Less Hanger	1.2	0.5	
410467	Hanger for Pullet Trough Coupler	0.1	0.0	
410466	Intermediate Hanger for Pullet Trough	0.2	0.1	
411036	Heavy Duty "J" Hanger	0.7	0.3	
410070	Trough Clean-Out Cover - includes 4 Wing Nuts	1.7	0.8	
610544	Trough Clean-Out Cover - includes 2 Wing Nuts	0.7	0.3	
410084	10' Trough Cover	6.0	2.7	
410085	12' Trough Cover	6.6	3.0	
631865	1.25" OD x 20' 14GA Pipe with Holes	17.8	8.1	
631811	1.25" Dia Pipe Coupler Kit	0.7	0.3	
631812	1.25" OD pipe Plug	0.0	0.0	

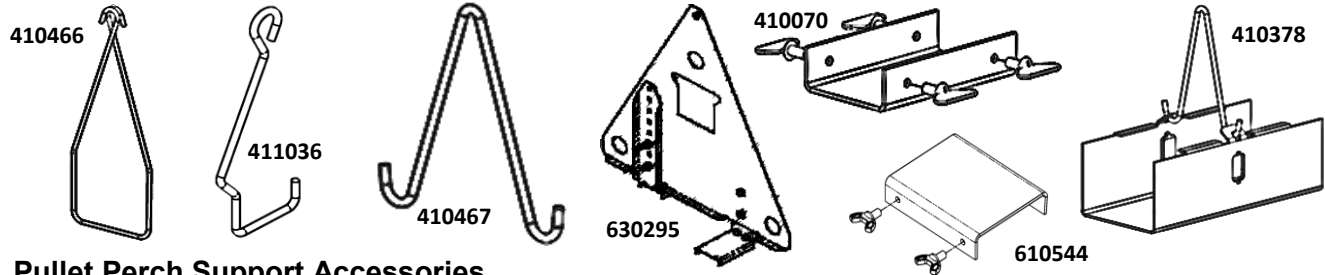

### Pullet Perch Support Accessories

VC316	1.163" Tube 10' long with coupler (includes VC318 tube & VC317 coupler)	4.4	1.98	
631233	End Plug Tube Cap	0.0	0.00	
420089	Perch Hanger Pullet Trough 1.163" Tube	0.7	0.33	
631441	Perch Support Pullet Trough 1.163" Tube	0.2	0.09	
630431	Strap for 1.163" Tube	0.0	0.01	
690142	Screw for Strap (2 required per strap)	0.0	0.00	

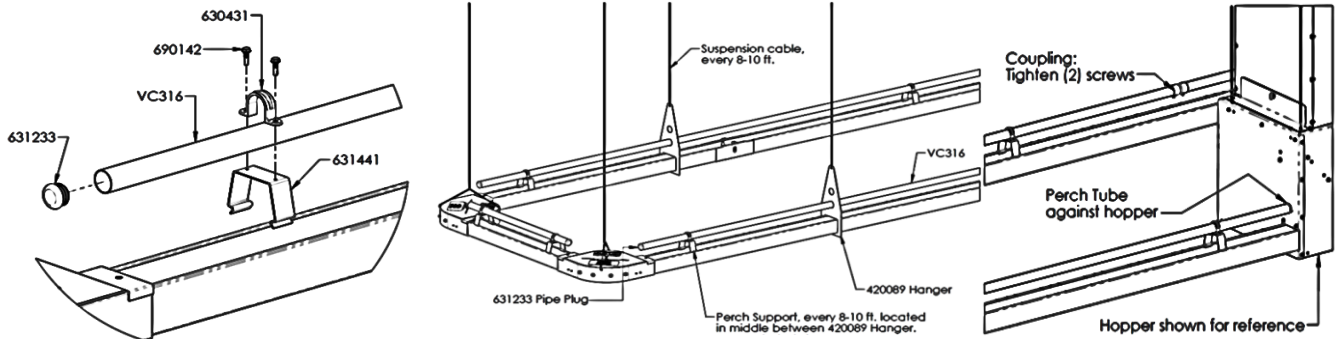

### Floor Trough Couplers

410361	Floor Stand Only for Floor Trough Coupler - Painted	2.3	0.5	
410664	Floor Stand Only for Floor Trough Coupler - Plastic*	0.7	0.3	
411048	Floor Stand Only for Floor Trough Coupler - Stainless Steel	2.4	1.1	
420318	8" Floor Trough Coupler with Painted Floor Stand	3.9	1.8	
420320	8" Floor Trough Coupler Less Stand	2.9	1.3	

\* Not for use in Perching Applications

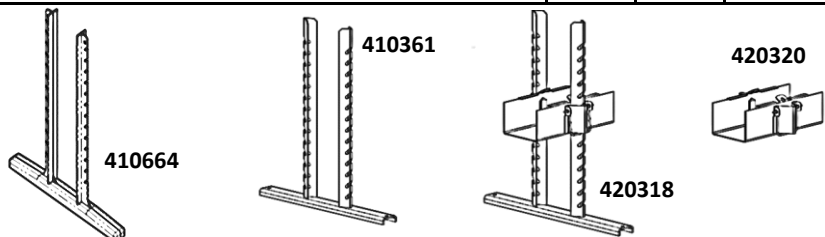

## Notes Regarding Selection of Short Trough Sections

Choose the below part numbers for shorter length hen and pullet troughs. These can be used at the ends of lines and will come with factory cut ends for ease of installation. Choose the short trough part number according to what outside of trough dimension and hen or pullet trough. Be careful to consider hopper placement. Some hoppers cannot be placed directly opposite from each other depending on the trough outside dimension. Reference below recommendations. If hoppers cannot be placed directly opposite, they can fit if offset from one another.

**3 ft. outside:** 1 line suspended hoppers will fit opposite each other with gap between. 2 line & 4 line suspended hoppers will not. All floor hoppers will not.

**4 ft. outside:** 1 line & 2 line suspended hoppers will fit opposite each other with gap between. 4 line suspended will not. All floor hoppers will not.

**5 ft. outside:** All suspended hoppers will fit opposite each other. All floor hoppers will not.

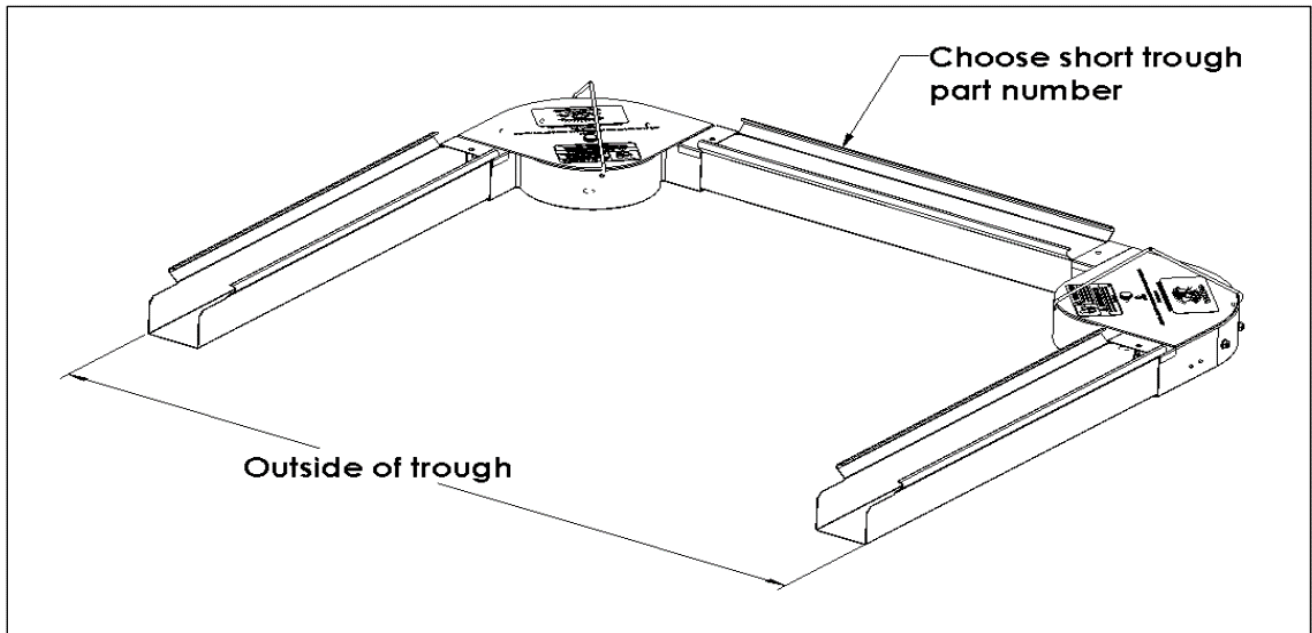

New Hen #	Description
420326	Hen trough, for 4 ft. outside of trough dimension (29.75 in. long)
420327	Hen trough, for 5 ft. outside of trough dimension (41.75 in. long)

New pullet #	Description
420328	Pullet trough, for 3 ft. outside of trough dimension (17.75 in. long)
420329	Pullet trough, for 4 ft. outside of trough dimension (29.75 in. long)
420330	Pullet trough, for 5 ft. outside of trough dimension (41.75 in. long)

### SHORT HEN TROUGH SECTIONS

CATALOG #	ITEM DESCRIPTION	SHIP WEIGHT		LIST PRICE
		LBS.	KG.	
420326	Hen Trough, for 4' outside of tough dimension. 29.75" (75.6cm)	4.3	2.0	
420327	Hen Trough, for 5' outside of trough dimension, 41.75" (106.0cm)	6.2	2.8	

### SHORT PULLET TROUGH SECTIONS

CATALOG #	ITEM DESCRIPTION	SHIP WEIGHT		LIST PRICE
		LBS.	KG.	
420328	Pullet Trough for 3' outside of trough dimension. 17.75" (45.1cm)	2.2	1.0	
420329	Pullet Trough for 4' outside of trough dimension. 29.75" (75.6cm)	3.7	1.7	
420330	Pullet Trough for 5' outside of trough dimension. 41.75" (106.0cm)	5.2	2.4	

## WIRE GRILL FOR HEN & PULLET TROUGH

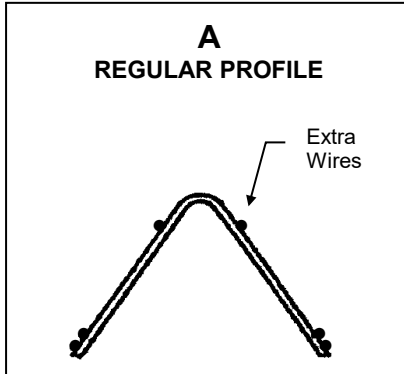

See  
**REGULAR PROFILE**  
 Grills on  
 Pages 14-17 & 14-18

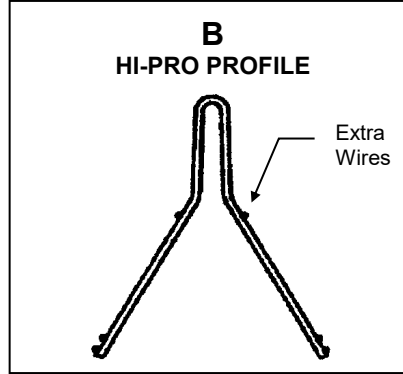

See  
**HI-PRO PROFILE**  
 Grills on  
 Page 14-19

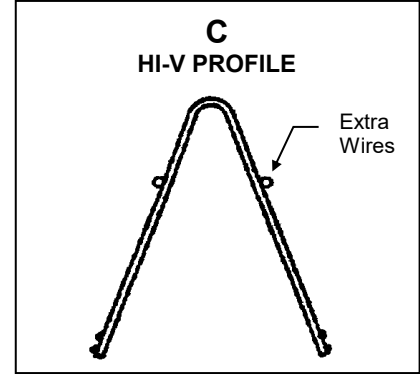

See  
**HI-V PROFILE**  
 Grills on  
 Page 14-20

### GRILL END CAPS

CATALOG NUMBER	ITEM DESCRIPTION	SHIP WEIGHT		LIST PRICE
		LBS.	KGS	
410484	End Cap for Regular Profile Hen Trough Grills	0.11	0.05	
410394	End Cap for Hi-Pro Profile Hen Trough Grills	0.10	0.05	
410399	End Cap for H-V Profile Hen Trough Grills	0.12	0.05	
410485	End Cap for Regular Profile Pullet Trough Grills	0.07	0.03	

## WIRE GRILL - REGULAR PROFILE

### IMPORTANT NOTE

All flat chain wire grills are special production - extended lead time possible on some sizes.  
 A special production net charge of **\$150** (subject to change) will apply on any order of less than 300 pieces.  
 Orders for these special production grills may not be cancelled or ship date delayed.

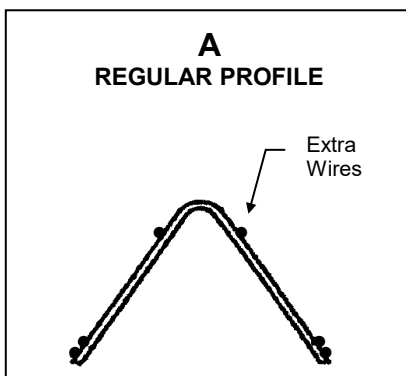

### REGULAR PROFILE GRILL

CATALOG NUMBER	OVERALL LENGTH	TROUGH TYPE	HORIZONTAL SPACING		EXTRA WIRES	VERT SPACING		SHIP WEIGHT		LIST PRICE
			IN	MM		IN	MM	LBS.	KGS	
410470	5	HT	1.625	41.3	0	0.000	0.0	2.6	1.2	
410471	6	HT	1.625	41.3	0	0.000	0.0	3.1	1.4	
410478	5	PT	1.625	41.3	0	0.000	0.0	2.4	1.1	
410479	6	PT	1.625	41.3	0	0.000	0.0	3.1	1.4	
415204	5	HT	1.625	41.3	1	3.312	84.1	2.8	1.3	
415205	6	HT	1.625	41.3	1	3.312	84.1	3.4	1.5	
415157	5	HT	1.625	41.3	2	2.250	57.2	3.0	1.4	
415158	6	HT	1.625	41.3	2	2.250	57.2	3.6	1.6	
416097	5	PT	1.625	41.3	2	2.250	57.2	3.1	1.4	
416098	6	PT	1.625	41.3	2	2.250	57.2	4.7	2.1	
415420	5	HT	1.688	42.9	0	0.000	0.0	2.5	1.1	
415421	6	HT	1.688	42.9	0	0.000	0.0	3.0	1.4	
415422	5	PT	1.688	42.9	0	0.000	0.0	2.3	1.1	
415423	6	PT	1.688	42.9	0	0.000	0.0	3.0	1.4	
415210	5	HT	1.688	42.9	1	3.312	84.1	2.6	1.2	
415211	6	HT	1.688	42.9	1	3.312	84.1	4.0	1.8	
420643	5	HT	1.688	42.9	2	2.250	57.2	3.1	1.4	
420644	6	HT	1.688	42.9	2	2.250	57.2	3.6	1.6	
415159	5	HT	1.688	42.9	2	2.500	63.5	3.0	1.3	
415160	6	HT	1.688	42.9	2	2.500	63.5	3.5	1.6	

Note: When one extra wire is specified, that wire will be at the apex of the grill with no choice of vertical spacing.



## WIRE GRILL - REGULAR PROFILE

### IMPORTANT NOTE

All flat chain wire grills are special production - extended lead time possible on some sizes.  
 A special production net charge of \$150 (subject to change) will apply on any order of less than 300 pieces.  
 Orders for these special production grills may not be cancelled or ship date delayed.

### REGULAR PROFILE GRILL (SEE FIGURE "A" ON PAGE 14-16)

CATALOG NUMBER	OVERALL LENGTH	TROUGH TYPE	HORIZONTAL SPACING		EXTRA WIRES	VERT SPACING		SHIP WEIGHT		LIST PRICE
			IN	MM		IN	MM	LBS.	KGS	
420490	5	HT	1.750	44.5	0	0.000	0.0	2.4	1.1	
420488	6	HT	1.750	44.5	0	0.000	0.0	3.2	1.5	
420501	5	PT	1.750	44.5	0	0.000	0.0	2.5	1.1	
420502	6	PT	1.750	44.5	0	0.000	0.0	3.2	1.5	
415206	5	HT	1.750	44.5	2	2.250	57.2	2.9	1.3	
415207	6	HT	1.750	44.5	2	2.250	57.2	3.4	1.5	
415217	5	PT	1.750	44.5	2	2.250	57.2	3.0	1.4	
415218	6	PT	1.750	44.5	2	2.250	57.2	3.5	1.6	
420683	5	HT	1.750	44.5	2	2.500	63.5	3.0	1.3	
420684	6	HT	1.750	44.5	2	2.500	63.5	4.1	1.9	
415215	5	HT	1.750	44.5	2	2.559	65.0	3.0	1.3	
415216	6	HT	1.750	44.5	2	2.559	65.0	3.6	1.6	
415142	5	HT	1.770	45.0	2	2.756	70.0	3.0	1.3	
415143	6	HT	1.770	45.0	2	2.756	70.0	3.6	1.6	
420504	5	HT	1.890	48.0	0	0.000	0.0	2.5	1.1	
420505	6	HT	1.890	48.0	0	0.000	0.0	3.2	1.5	
420649	5	PT	1.890	48.0	2	2.250	57.2	3.0	1.4	CALL
420676	6	PT	1.890	48.0	2	2.250	57.2	0.0	0.0	
420645	5	HT	1.890	48.0	2	2.559	65.0	3.0	1.3	
420646	6	HT	1.890	48.0	2	2.559	65.0	3.5	1.6	
410472	5	HT	2.500	63.5	0	0.000	000	2.0	0.9	
410473	6	HT	2.500	63.5	0	0.000	000	2.6	1.2	
410474	5	Pullet	2.500	63.5	0	0.000	000	2.0	0.9	
410475	6	Pullet	2.500	63.5	0	0.000	000	2.6	1.2	
415140	5	HT	2.500	63.5	1	3.312	84.1	2.7	1.2	
415141	6	HT	2.500	63.5	1	3.312	84.1	3.3	1.5	
410923	5	HT	2.500	63.5	2	2.250	57.2	2.7	1.2	
410924	6	HT	2.500	63.5	2	2.250	57.2	3.5	1.6	
415208	5	HT	2.500	63.5	2	2.470	62.7	2.7	1.2	
415209	6	HT	2.500	63.5	2	2.470	62.7	3.5	1.6	

Note: When one extra wire is specified, that wire will be at the apex of the grill with no choice of vertical spacing.

## WIRE GRILL - HI-PRO PROFILE

### IMPORTANT NOTE

All flat chain wire grills are special production - extended lead time possible on some sizes.  
 A special production net charge of \$150 (subject to change) will apply on any order of less than 300 pieces.  
 Orders for these special production grills may not be cancelled or ship date delayed.

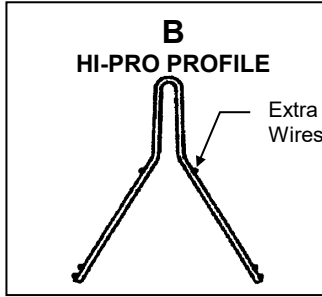

### HI-PRO PROFILE GRILL

CATALOG NUMBER	OVERALL LENGTH	TROUGH TYPE	HORIZONTAL SPACING		EXTRA WIRES	VERT SPACING		SHIP WEIGHT		LIST PRICE
			IN	MM		IN	MM	LBS.	KGS	
420544	4	HT	1.625	41.3	2	2.250	57.2	3.1	1.4	
420542	5	HT	1.625	41.3	2	2.250	57.2	3.9	1.8	
420543	6	HT	1.625	41.3	2	2.250	57.2	3.9	1.8	
420547	5	HT	1.625	41.3	2	2.500	63.5	4.0	1.8	
420548	6	HT	1.625	41.3	2	2.500	63.5	4.7	2.1	
420687	5	HT	1.625	41.3	2	2.625	66.7	4.0	1.8	
420688	6	HT	1.625	41.3	2	2.625	66.7	4.7	2.1	
410205	5	HT	1.625	41.3	2	3.102	78.8	3.1	1.4	
410206	6	HT	1.625	41.3	2	3.102	78.8	5.9	2.7	
420691	5	HT	1.688	42.9	2	2.250	57.2	4.0	1.8	
420692	6	HT	1.688	42.9	2	2.250	57.2	5.3	2.4	
420633	5	HT	1.688	42.9	2	2.502	63.6	4.0	1.8	
420634	6	HT	1.688	42.9	2	2.502	63.6	3.8	1.7	
420689	5	HT	1.688	42.9	2	2.625	66.7	4.0	1.8	
420690	6	HT	1.688	42.9	2	2.625	66.7	0.0	0.0	
410480	5	HT	1.688	42.9	2	3.102	78.8	3.8	1.7	
410481	6	HT	1.688	42.9	2	3.102	78.8	4.9	2.2	
415136	6	HT	1.732	44.0	2	2.500	63.5	4.1	1.9	
410609	5	HT	1.732	44.0	2	3.102	78.8	3.8	1.7	
410608	6	HT	1.732	44.0	2	3.102	78.8	4.6	2.1	
415219	5	HT	1.750	44.5	2	2.250	57.2	3.6	1.6	
415220	6	HT	1.750	44.5	2	2.250	57.2	4.7	2.1	
415125	5	HT	1.750	44.5	2	2.500	63.5	4.0	1.8	
420685	5	HT	1.813	46.1	2	2.313	58.7	3.8	1.7	
420686	6	HT	1.813	46.1	2	2.313	58.7	0.0	2.1	
420535	6	HT	1.813	46.1	2	2.500	63.5	4.5	2.1	
420537	5	HT	1.813	46.1	2	2.500	63.5	3.7	1.7	
415212	5	HT	2.000	50.8	2	2.352	59.7	3.6	1.6	
415177	5	HT	2.000	50.8	2	2.000	50.8	3.6	1.6	
415178	6	HT	2.000	50.8	2	2.000	50.8	4.3	2.0	
415179	5	HT	2.000	50.8	2	1.688	42.9	3.6	1.6	
415180	6	HT	2.000	50.8	2	1.688	42.9	4.3	2.0	

## WIRE GRILL - HI-V PROFILE

### IMPORTANT NOTE

All flat chain wire grills are special production - extended lead time possible on some sizes.  
 A special production net charge of **\$150** (subject to change) will apply on any order of less than 300 pieces.  
 Orders for these special production grills may not be cancelled or ship date delayed.

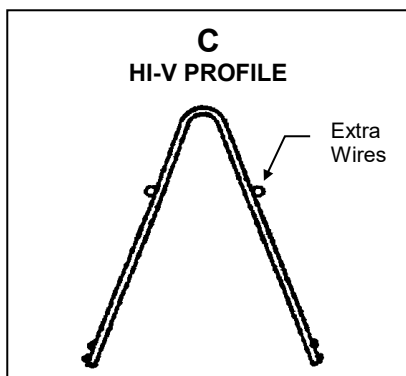

### HI-V PROFILE GRILL

CATALOG NUMBER	OVERALL LENGTH	TROUGH TYPE	HORIZONTAL SPACING		EXTRA WIRES	VERT SPACING		SHIP WEIGHT		LIST PRICE
			IN	MM		IN	MM	LBS.	KGS	
420679	5	HT	1.625	41.3	2	2.625	66.7	4.0	1.8	
420680	6	HT	1.625	41.3	2	2.625	66.7	0.0	0.0	
410668	6	HT	1.625	41.3	2	2.932	74.5	4.7	2.1	
415213	5	Hen	1.625	41.3	2	3.102	78.8	4.0	1.8	
415214	6	Hen	1.625	41.3	2	3.102	78.8	3.3	1.5	
410395	5	Hen	1.688	42.9	2	3.102	78.8	3.8	1.7	
410398	6	Hen	1.688	42.9	2	3.102	78.8	4.7	2.1	
410290	5	PT	1.688	42.9	2	3.102	78.8	3.8	1.7	
410291	6	PT	1.688	42.9	2	3.102	78.8	4.6	2.1	
420681	5	HT	1.732	44.0	2	3.102	78.8	3.8	1.7	
420682	6	HT	1.732	44.0	2	3.102	78.8	0.0	0.0	
415166	5	HT	1.770	45.0	2	2.362	60.0	3.5	1.6	
415167	6	HT	1.770	45.0	2	2.362	60.0	3.5	1.6	
416107	5	HT	1.770	45.0	2	2.560	60.0	3.8	1.7	
416108	6	HT	1.770	45.0	2	2.560	60.0	4.4	2.0	
415175	5	HT	1.850	47.0	2	2.362	60.0	3.7	1.7	
415176	6	HT	1.850	47.0	2	2.362	60.0	4.4	2.0	
420506	5	HT	2.500	63.5	2	3.102	78.8	3.8	1.7	
420507	6	HT	2.500	63.5	2	3.102	78.8	4.6	2.1	

## Narrow Loop Flat Chain Feeders

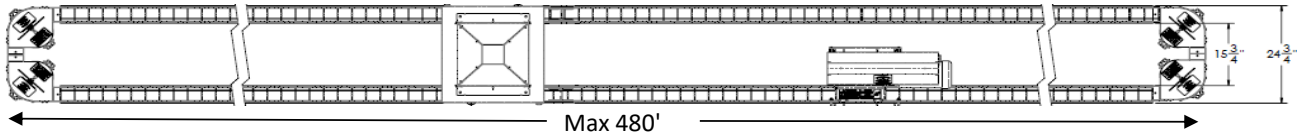

2-WAY DIRECT DRIVE NARROW LOOP FEEDERS - 120 FPM - MAX LENGTH 480'		SHIP WEIGHT		LIST PRICE
		LBS.	KGS.	
CATALOG #	ITEM DESCRIPTION			
421960	1-Line Suspended Model Auxiliary Fill Hopper - 60 Lb. (27Kg) Hopper Capacity - Galvanized Construction - Includes (2) 420355 - Extension Hopper Available Below	68.0	30.8	
421970	Flat Chain Large Cap Extension Hopper 350 Lb Capacity	61.5	27.9	
420900	Lo Pro Extension Hopper with Cover- 155 Lb Capacity	34.0	15.4	
430091	90 Deg Corner Suspended/ Floor	13.3	6.0	
410300	10' Hen Trough	18.0	8.2	
410308	12' Hen Trough	21.3	9.7	
410328	8" Ht Coupler Less Hanger	1.5	0.7	
411036	Open Wire Hanger, Flat Chain	0.7	0.3	
410403-Q0050	2.75" Flat Chain (50Ft)	35.9	16.3	
410403-Q5400	2.75" Flat Chain (Skid Of 5400Ft)	3,880.0	1,760.0	
410403-Q59400	2.75" Flat Chain - Truckload Quantity of 59,400 ft	42,680.0	19,359.6	
420305	Flat Chain Breaker	3.4	1.5	
416113	Grill 5-HP-HT-250-1-144-FE 1 Side Restricted	2.6	1.2	
416114	Grill 6-HP-HT-250-1-144-FE 1 Side Restricted	3.5	1.6	
410394	End Cap For High-Pro Profile Grill	0.1	0.0	
411071	Trough Spacer (requires ording (2) - 010615 & (2) 012792 for each 411071	1.0	0.5	
420335	Pullet Trough, 5.5", Narrow Loop Flat Chain	0.7	0.3	
410070	Trough Clean-Out Cover - Includes 4 Wing Nuts	1.7	0.8	
610544	Trough Clean-Out Cover - Includes 2 Wing Nuts	0.7	0.3	
421980	Narrow Straight Line Winch Assembly, 800Nm, 1PH, 240V, 60H, 3.1 RPM	80.0	36.3	
922330	Narrow Winch Controller - 220-240 VAC 50/60Hz (1 per Winch)	2.9	1.3	

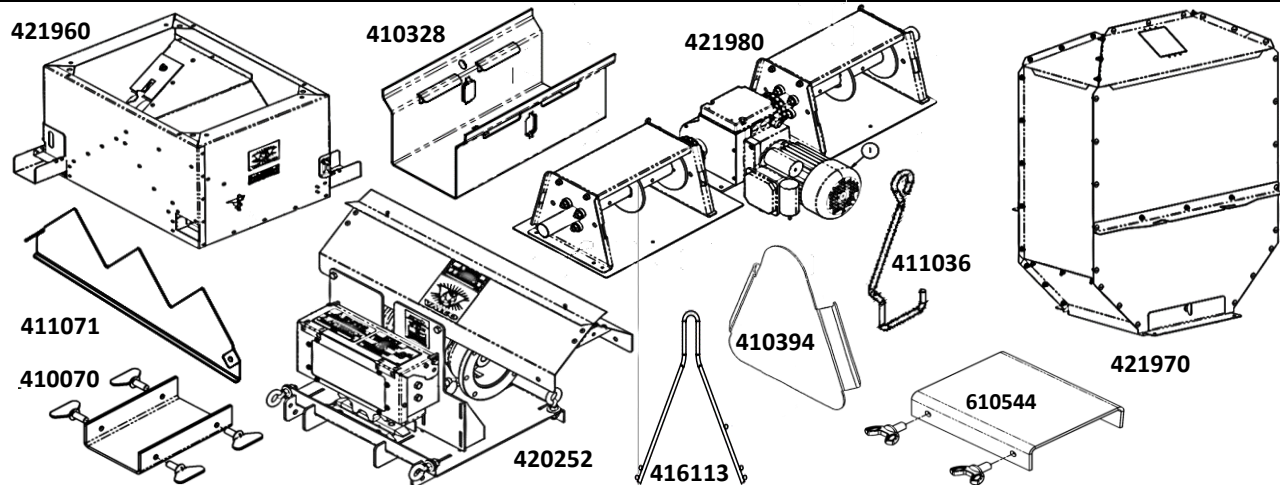

### TO ORDER A COMPLETE NARROW LOOP FEEDER:

- Order (1) hopper and (4) corners (and extension hopper if desired)
- Select desired length of hen trough, chain, and choice of grill (max 480' total length - 964' of chain length), couplers, grill caps, and hangers
- See page 14-03 for hp recommendations. Order direct drive(s) (see page 14-09) and motor(s) (see pages 14-03 and 14-10) based on those recommendations.  
In situations where the chain could be running while the system is lowered, a 120 FPM chain speed will help distribute the feed more evenly around the system.
- Order winching and suspension cable as needed, supporting as per hen standard hen trough  
Industry Standard for Male Breeders is 7 linear inches of trough space per bird.  
Minimum recommended feed is 1.2 lb (.45 kg) for every 1' (0.3 m) of length of system or 2' (0.6 m) of trough. For example, for a 360' (110 m) long system, a minimum of 430 lbs (114 kg) of feed is recommended to ensure feed will get around the entire system.
- Order (1) 411071 trough spacer, (2) 010615 bolts, and (2) 012792 nuts for every 30' of total length of system.

## Manual Feed Troughs

### How to Order

1. Order 2 420980
2. Overall length divided by 10' or 12' to get the number of trough pieces.
3. Order 1 420980 & 420992 for every trough piece ordered

### Manual Feed Troughs

CATALOG #	ITEM DESCRIPTION	SHIP WEIGHT		LIST PRICE
		LBS.	KGS.	
410300	10' Hen Trough	18.0	8.2	
416113	Grill - 5' restricted on 1 side - Need 2 for 10' Trough	2.6	1.2	
410308	12' Hen Trough	21.3	9.7	
416114	Grill - 6' restricted on 1 side - Need 2 for 12' Trough	3.5	1.6	
420980	Manual Feed Trough Stand	21.0	9.5	
420992	Trough Bracket	1.3	0.6	
450437	Spring for Anti-Roost Shocker Wire	0.1	0.1	
VG342	1/16" Anti-Roost Wire	0.0	0.0	
VC353	1/16" Clamp for Anti-Roost Wire	0.0	0.0	

