



SECTION 04 FLEXIBLE AUGER FILL SYSTEMS

IN THIS CATALOG SECTION

PAGE NUMBER	CONTENTS
04-01	Table of Contents & Fill System Disclaimers
04-02	How to Order a Fill System
04-03	Fill Systems Information
04-04 thru 04-07	Lower Boots/Unloaders
04-08 thru 04-13	Tube, Connectors & Auger
04-14 thru 04-17	Drop Outlets & Downspout Tubes
04-18 thru 04-22	Discharge Heads - Steel, Poly, and Downspout Tubes
04-23	Port & Driver Kits
04-24 thru 04-25	Direct Drive Units, V-Belt Unit
04-26	Switches & Controls
04-27 thru 04-30	Fill Systems Entrance Drawings
04-31 thru 04-34	Model 720 Fill Systems - 2.25"/55mm
04-35 thru 04-38	Model 725 Fill Systems - 3"/75mm
04-39 thru 04-42	Model 730 Fill Systems - 3"/75mm
04-43 thru 04-46	Model 735HV Fill Systems - 3.5"/90mm - High Volume
04-47 thru 04-50	Model 735HM Fill Systems - 3.5"/90mm - High Moisture

Model 740 (4.25") FLEXIBLE AUGER FILL SYSTEMS

04-51	Table of Contents & Fill System Disclaimers
04-52 & 04-53	Fill Systems Entrance Drawings / HP requirements & Application Notes
04-54	Upper Boot / Adapter
04-55	Lower Boots / Unloaders
04-56	Flexible Auger / Steel Tubes
04-57	Tubes, Hangers & Feed Screener
04-58	Drop Outlets & Downspout Tubes
04-59	Discharge Heads
04-60	Discharge Head Kits / Port & Driver Kits
04-61	Flag System Accessories / Switches & Controls
04-62	Direct Drive Table
04-63	Direct Drive Motors and Gear Box Units

REPAIRS

SEE REPAIR LISTING & REFERENCE MATERIAL IN SEPARATE CATALOG

VAL-CO SYSTEM DISCLAIMER

Recommendations, opinions, or advice given by Val-Co regarding equipment, systems, or installation shall be accepted at the user's own discretion and shall not constitute any warranty or guarantee of such products or their performance. Val-Co assumes no obligation or liability on account of any recommendation, opinions or advice as to the choice, installation, or use of products.

Before installation is made on any product or system, the user has a responsibility to research and comply with all federal, state, and local codes which may apply to the location and installation.

VAL-CO PRODUCT DISCLAIMER

Val-Co products are designed and manufactured to provide reliable performance. Even reliable products may experience occasional failures, due to variance of installation, environment, and the recognized life cycle of a product. Due to the possibility of failure, the user should provide adequate backup systems and an alarm or acknowledge willingness to accept the risk of loss.

WARRANTY

SEE CATALOG SECTION 01 TO REVIEW WARRANTY & DISCLAIMERS

HOW TO ORDER A FILL SYSTEM

TO ORDER A VAL-CO FLEXIBLE AUGER FILL SYSTEM:

- ▶ Refer to system notes on page 04-03 to determine which system best meets your needs.
- ▶ Determine plastic upper boot and lower boot required and order from pages 04-04 thru 04-05.
- ▶ Refer to system sketches on page 04-27 thru 04-30 and then to the appropriate corresponding charts on pages 04-31 thru 04-50. Using your selected chart as a guideline, select the line components required for your system. Select & order components as indicated from the listings on pages 04-06 thru 04-21.
- ▶ Additional savings are available if you order PVC tubes and Flexible Auger in bulk quantities shown on pages 04-08 and 04-13.
- ▶ Determine number of drop outlets needed and order from pages 04-14 & 04-16 along with any downspout tubes and/or accessories needed.
- ▶ Select and order feed level control switch from page 04-26.
- ▶ Contact your Val-Co sales representative or Customer Service for assistance if needed.

FLEXIBLE AUGER FEED DELIVERY SYSTEMS

MODEL 720 2.25" (55mm) FLEXIBLE AUGER FILL SYSTEMS

Used to convey dry ground feed and crumble type mash - maximum moisture content 18%. Maximum particle size 1/8" diameter x 1/2" long. Do not use for large pellets or shelled corn. PVC tubes are 2.25" (55mm) outside diameter; flexible auger is 1.52" outside diameter. Approximate feed delivery rate is 15 lbs. per minute or 900 lbs. per hour based on 40 lbs./cubic foot feed density and 359 rpm drive unit.

MODEL 725 "PELLET" 3" (75mm) FLEXIBLE AUGER FILL SYSTEMS

Used to convey dry ground feed and crumble type mash - maximum moisture content 18%. Maximum particle size 1/8" diameter x 1/2" long. System is recommended for pellets or shelled corn. PVC tubes are 3" (75mm) outside diameter; flexible auger is 2.25" outside diameter. Approximate feed delivery rate is 35 lbs. per minute or 2100 lbs. per hour based on 40 lbs./cubic foot feed density and 359 rpm drive unit.

MODEL 730 3" (75mm) FLEXIBLE AUGER FILL SYSTEMS

Used to convey dry ground feed and crumble type mash - maximum moisture content 18%. Maximum particle size 1/8" diameter x 1/2" long. Do not use for large pellets or shelled corn. PVC tubes are 3" (75mm) outside diameter; flexible auger is 2.38" outside diameter. Approximate feed delivery rate is 50 lbs. per minute or 3000 lbs. per hour based on 40 lbs./cubic foot feed density and 359 rpm drive unit.

MODEL 735 HV 3.5" (90mm) FLEXIBLE AUGER FILL SYSTEMS

Used to convey dry ground feed and crumble type mash - maximum moisture content 18%. Maximum particle size 3/16" diameter x 1/2" long. Do not use for large pellets or shelled corn. PVC tubes are 3.5" (90mm) outside diameter; flexible auger is 2.71" outside diameter. Approximate feed delivery rate is 100 lbs. per minute or 6000 lbs. per hour based on 40 lbs./cubic foot feed density and 359 rpm drive unit.

MODEL 735 HM 3.5" (90mm) FLEXIBLE AUGER FILL SYSTEMS

Used to convey dry ground feed and crumble type mash - maximum moisture content 27%. Maximum particle size 3/8" diameter x 3/4" long. Do not use for large pellets or shelled corn. PVC tubes are 3.5" (90mm) outside diameter; flexible auger is 2.38" outside diameter. Approximate feed delivery rate is 50 lbs. per minute or 3000 lbs. per hour based on 40 lbs./cubic foot feed density and 359 rpm drive unit.

MODEL 740 HV 4.25" (108mm) FLEXIBLE AUGER FILL SYSTEMS

See Pages 04-51 & 04-52 for more detail

Used to convey dry ground feed and crumble type mash. Maximum particle size 3/16" diameter x 1/2" long.
PVC tubes are 4.5" (108mm) outside diameter; flexible auger is 3.55" outside diameter.

Approximate feed delivery rate is 220 lbs. per minute or 13,200 lbs. per hour based on 40 lbs./cubic foot feed density and 359 rpm drive unit.

SYSTEM NOTES

Auger boots, tube hangers, feed drop outlets, downspout tubes, feed control switches and other optional items are not included with the systems listed. Order these items separately.

Size your system to make the maximum operating time four hours per day. Some applications may require two flexible auger fill systems or possibly a 4" or 6" rigid auger system to meet the desired delivery rate.

A time clock or other control is recommended with all systems to prevent excess empty auger operation and other malfunctions.

Multiple bin pass-thru or tandem systems are recommended when extra feed storage or dual rations are required.

Extended length systems are complete with components to transfer from one feed line to another. These systems are available with direct drive power units only. RECOMMENDATION: Select a drive unit with a faster output rpm for the extended system than for the supply (entrance or pass-thru) system.

All systems are normally wired for 230V, 60HZ, 1 Phase operation. Additional motors (60HZ - 3 Phase, 50HZ - 1 Phase, & 50HZ - 3 Phase) are also available.

Standard drive unit (both v-belt and direct drive) is 359 rpm at 60HZ, 368 rpm at 50HZ operation. Alternate speeds (190, 250, & 441 rpm at 60HZ -- 159, 208, & 298 rpm at 50HZ) are also available.

IMPORTANT

WHEN USING ADDITIONAL FORMED TUBES ON A SYSTEM, FOR EACH ADDITIONAL 90° OF FORMED PVC TUBE ADDED TO A LINE DECREASE THE MAXIMUM LINE LENGTH FOR EACH MOTOR SIZE BY 30 FEET.

UPPER BOOT TRANSITIONS & LOWER BOOT KITS

UPPER BOOT TRANSITIONS		SHIP WEIGHT		LIST PRICE
		LBS.	KG.	
CATALOG #	ITEM DESCRIPTION			
500475	30 Degree Plastic Upper Boot Transition - Green	4.9	2.2	
500857	30 Degree Plastic Upper Boot Transition - Translucent	4.4	2.0	
500575	30 Degree Plastic Upper Boot Transition - Clear	4.6	2.1	
500485	Straight Plastic Upper Boot Transition - Green	5.5	2.5	
500855	Straight Plastic Upper Boot Transition - Translucent	5.6	2.5	
500585	Straight Plastic Upper Boot Transition - Clear	4.8	2.2	
700010	Straight Double Plastic Upper Boot Transition - Green	7.0	3.2	
500850	Straight Triple Boot Transition	55.6	25.2	
501480	7.5° Transition Wedge Assembly Kit	2.9	1.3	
501470	15° Transition Wedge Assembly Kit (can be used with 30° Boot to achieve 45°)	4.4	2.0	

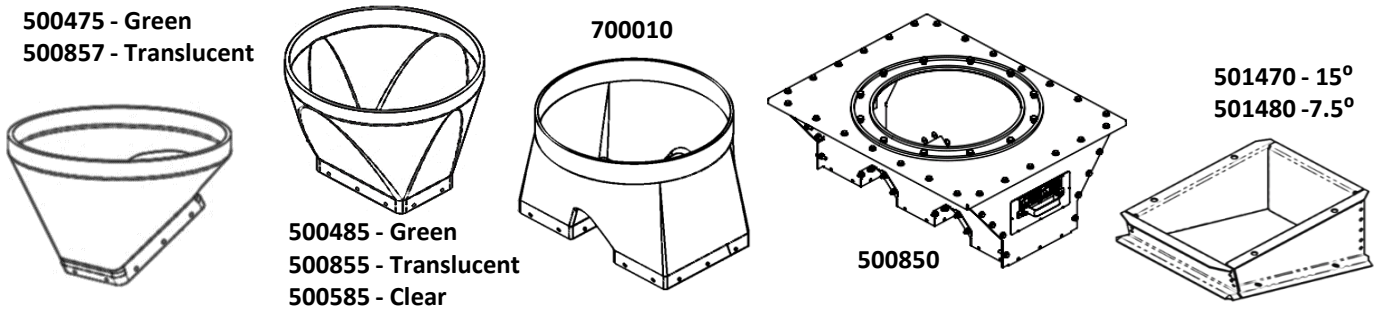

MODEL 720 - 2.25" (55mm) LOWER BOOTS

720963	2.25" Single Outlet Lower Boot - Complete with Anchor & Bearing Kit and Single SV	23.7	10.7	
720964	2.25" Single Outlet Lower Boot - Complete with Anchor & Bearing Kit - without SV	18.3	8.3	
720965	2.25" Twin Outlet Lower Boot - Complete with Anchor & Bearing Kits (2) and Single SV	37.5	9.8	
720966	2.25" Twin Outlet Lower Boot - Complete with Anchor & Bearing Kits (2) and Split SV	37.5	17.0	
720967	2.25" Twin Outlet Lower Boot - Complete with Anchor & Bearing Kits (2) - without SV	32.1	14.6	
720968	2.25" Combination Twin Outlet Lower Boot - Complete with Anchor & Bearing Kit, P-T Kit, Baffle/Restrictor and Split SV	40.8	18.5	
720940	2.25" Single Outlet Pass-Thru Lower Boot - Complete with P-T Kit, Baffle/Restrictor and Single SV	25.1	11.4	
720960	2.25" Twin Outlet Pass-Thru Lower Boot - Complete with P-T Kits (2), Baffle/Restrictor and Single SV	39.7	18.0	
720961	2.25" Twin Outlet Pass-Thru Lower Boot - Complete with P-T Kits (2), Baffle/Restrictor and Split SV	32.5	14.7	

Boot kits shipped in multiple cartons - see boot component listing on pages 04-06.

MODEL 725 - 3" (75mm) LOWER BOOTS (Pellet Auger System)

725931	3" Single Outlet Lower Boot - Complete with Anchor & Bearing Kit and Single SV	26.9	12.2	
725937	3" Single Outlet Lower Boot Stainless Steel - Complete with Anchor & Bearing Kit and Single SV	30.0	13.6	
725932	3" Single Outlet Lower Boot - Complete with Anchor & Bearing Kit - without SV	21.5	9.8	
725938	3" Single Outlet Lower Boot Stainless Steel - Complete with Anchor & Bearing Kit - without SV	23.1	10.5	
725933	3" Twin Outlet Lower Boot - Complete with Anchor & Bearing Kits (2) and Single SV	45.6	20.7	
725934	3" Twin Outlet Lower Boot - Complete with Anchor & Bearing Kits (2) and Split SV	46.1	20.9	
725935	3" Twin Outlet Lower Boot - Complete with Anchor & Bearing Kits (2) - without SV	40.2	18.2	
725936	3" Combination Twin Outlet Lower Boot - Complete with Anchor & Bearing Kit, P-T Kit, and Split SV	46.5	21.1	
730940	3" Single Outlet Pass-Thru Lower Boot - Complete with P-T Kit, and Single SV	26.1	11.8	
730960	3" Twin Outlet Pass-Thru Lower Boot - Complete with P-T Kits (2), and Single SV	43.3	19.6	
730961	3" Twin Outlet Pass-Thru Lower Boot - Complete with P-T Kits (2), and Split SV	43.8	19.9	

Boot kits shipped in multiple cartons - see boot component listing on pages 04-06.

MODEL 730 - 3" (75mm) LOWER BOOTS (Standard System)

CATALOG #	ITEM DESCRIPTION	SHIP WEIGHT		LIST PRICE
		LBS.	KG.	
730943	3" Single Outlet Lower Boot - Complete with Anchor & Bearing Kit and Single SV	24.6	11.2	
730944	3" Single Outlet Lower Boot - Complete with Anchor & Bearing Kit - without SV	19.2	8.7	
731076	3" Single Outlet Lower Boot Stainless Steel- Complete with Anchor & Bearing Kit - without SV	23.4	10.6	
730945	3" Twin Outlet Lower Boot - Complete with Anchor & Bearing Kits (2) and Single SV	43.3	19.6	
730946	3" Twin Outlet Lower Boot - Complete with Anchor & Bearing Kits (2) and Split SV	43.3	19.6	
730947	3" Twin Outlet Lower Boot - Complete with Anchor & Bearing Kits (2) - without SV	37.9	17.2	
730948	3" Combination Twin Outlet Lower Boot - Complete with Anchor & Bearing Kit, P-T Kit, Baffle/Restrictor and Split SV	44.3	20.1	
730940	3" Single Outlet Pass-Thru Lower Boot - Complete with P-T Kit, Baffle/Restrictor and Single SV	26.1	11.8	
730960	3" Twin Outlet Pass-Thru Lower Boot - Complete with P-T Kits (2), Baffle/Restrictor and Single SV	43.3	19.6	
730961	3" Twin Outlet Pass-Thru Lower Boot - Complete with P-T Kits (2), Baffle/Restrictor and Split SV	43.8	19.9	
731050	3" Single Outlet SS Lower Boot - Complete with Anchor & Bearing Kit and Single SV	24.5	11.1	

Boot kits shipped in multiple cartons - see boot component listing on pages 04-06.

MODEL 735HV - 3.5" (90mm) HV LOWER BOOTS

735993	3.5" HV Single Outlet Lower Boot - Complete with Anchor & Bearing Kit and Single SV	27.3	12.4	
735994	3.5" HV Single Outlet Lower Boot - Complete with Anchor & Bearing Kit - without SV	21.9	9.9	
735995	3.5" HV Twin Outlet Lower Boot - Complete with Anchor & Bearing Kits (2) and Single SV	21.9	9.9	
735996	3.5" HV Twin Outlet Lower Boot - Complete with Anchor & Bearing Kits (2) and Split SV	48.6	22.0	
735997	3.5" HV Twin Outlet Lower Boot - Complete with Anchor & Bearing Kits (2) - without SV	42.7	19.4	
735998	3.5" HV Combination Twin Outlet Lower Boot - Complete with Anchor & Bearing Kit, P-T Kit, Baffle/Restrictor and Split SV	47.1	21.4	
735940	3.5" HV/HM Single Outlet Pass-Thru Lower Boot - Complete with P-T Kit, Baffle/Restrictor and Single SV	26.8	12.2	
735960	3.5" HV/HM Twin Outlet Pass-Thru Lower Boot - Complete with P-T Kits (2), Baffle/Restrictor and Single SV	44.1	20.0	
735961	3.5" HV/HM Twin Outlet Pass-Thru Lower Boot - Complete with P-T Kits (2), Baffle/Restrictor and Split SV	44.6	20.2	

Boot kits shipped in multiple cartons - see boot component listing on pages 04-06.

MODEL 735HM - 3.5" (90mm) HM LOWER BOOTS

735984	3.5" HM Single Outlet Lower Boot - Complete with Anchor & Bearing Kit and Single SV	26.4	12.0	
735985	3.5" HM Single Outlet Lower Boot - Complete with Anchor & Bearing Kit - without SV	19.5	8.8	
735986	3.5" HM Twin Outlet Lower Boot - Complete with Anchor & Bearing Kits (2) and Single SV	45.8	20.8	
735987	3.5" HM Twin Outlet Lower Boot - Complete with Anchor & Bearing Kits (2) and Split SV	45.8	20.8	
735988	3.5" HM Twin Outlet Lower Boot - Complete with Anchor & Bearing Kits (2) - without SV	40.4	18.3	
735989	3.5" HM Combination Twin Outlet Lower Boot - Complete with Anchor & Bearing Kit, P-T Kit, Baffle/Restrictor and Split SV	46.2	21.0	
735940	3.5" HV/HM Single Outlet Pass-Thru Lower Boot - Complete with P-T Kit, Baffle/Restrictor and Single SV	26.8	12.2	
735960	3.5" HV/HM Twin Outlet Pass-Thru Lower Boot - Complete with P-T Kits (2), Baffle/Restrictor and Single SV	44.1	20.0	
735961	3.5" HV/HM Twin Outlet Pass-Thru Lower Boot - Complete with P-T Kits (2), Baffle/Restrictor and Split SV	44.6	20.2	

Boot kits shipped in multiple cartons - see boot component listing on pages 04-06.

Lower Boot Adapters

730375	Lower boot adapter to attach to Broiler Feed Hoppers	2.6	1.8	
730296	Coupler for Val-co 730 Boot to AP/Cumberland 3" PBC Tube	1.8	1.8	

Feed Screener

501540	735 Auger Feed Screener	64.0	1.8	
--------	-------------------------	------	-----	--

Boot Safety Switch

730965	Boot Safety Switch - Mechanical 110-220v, 20 amp, 1 phase, 50-60hz	1.1	0.5	
455800	Boot Safety Switch - Proximity switch, 0-60 sec. delay, adj. sensitivity, 1P/220v/50-60	4.0	1.8	



FLEXIBLE AUGER LOWER BOOT KIT COMPONENT REQUIREMENTS		COMPONENTS & QUANTITY REQUIRED																							
		BASIC BOOTS						SLIDE VALVES		ANCHOR & BEARING KITS				PASS-THRU KITS			BOOT BAFFLES								
		COMPONENT →		SHIP WEIGHT →		CATALOG NUMBER & DESCRIPTION →		15.2	26.0	15.2	27.6	15.9	28.4	5.4	5.9	4.0	3.8	6.3	8.3	6.9	2.5	3.5	3.5	2.0	1.5
		CATALOG NUMBER OF BOOT KIT		BOOT KIT DESCRIPTION		720839	720849	730839	730849	735839	735849	500471	500371	720785	731023	731008	735878	735880	720885	730885	735885	730875	730878		
720963	2.25" Single - Combination SV	1								1		1													
720964	2.25" Single - Less SV	1										1													
720965	2.25" Twin - Single SV		1							1		2													
720966	2.25" Twin - Split SV		1								1	2													
720967	2.25" Twin - Less SV		1									2													
720968	2.25" Twin Combination - Split SV		1								1	1						1						1	
720940	2.25" Single Pass-Thru - Single SV	1								1								1				1			
720960	2.25" Twin Pass-Thru - Single SV		1							1								2						1	
720961	2.25" Twin Pass-Thru - Split SV		1								1							2						1	
725931	3" Single - Single SV - For 725			1						1			1												
725932	3" Single - Less SV - For 725			1									1												
725933	3" Twin - Single SV - For 725				1					1			2												
725934	3" Twin - Split SV - For 725				1						1		2												
725935	3" Twin - Less SV - For 725				1								2												
725936	3" Twin Combination - Split SV - For 725				1						1		1						1					1	
730940	3" Single Pass-Thru - Single SV		1							1									1			1			
730960	3" Twin Pass-Thru - Single SV			1						1									2					1	
730961	3" Twin Pass-Thru - Split SV			1							1								2					1	
730943	3" Single - Single SV		1							1				1											
730944	3" Single - Less SV		1												1										
730945	3" Twin - Single SV			1						1				2											
730946	3" Twin - Split SV			1							1			2											
730947	3" Twin - Less SV			1										2											
730948	3" Twin Combination - Split SV			1							1			1					1					1	
735993	3.5" HV Single - Single SV					1				1									1						
735994	3.5" HV Single - Less SV					1													1						
735995	3.5" HV Twin - Single SV						1			1									2						
735996	3.5" HV Twin - Split SV						1				1								2						
735997	3.5" HV Twin - Less SV						1												2						
735998	3.5" HV Twin Combination - Split SV						1				1								1			1		1	
735940	3.5" Single Pass-Thru - Single SV					1				1										1		1			
735960	3.5" Twin Pass-Thru - Single SV						1			1										2				1	
735961	3.5" Twin Pass-Thru - Split SV						1				1									2				1	
735984	3.5" HM Single - Single SV					1				1									1						
735985	3.5" HM Single - Less SV					1				1															
735986	3.5" HM Twin - Single SV						1			1									2						
735987	3.5" HM Twin - Split SV						1				1								2						
735988	3.5" HM Twin - Less SV						1												2						
735989	3.5" HM Twin Combination - Split SV						1				1								1					1	



LOWER BOOT COMPONENTS & FLAG / EXTENDED LENGTH SYSTEM ACCESSORIES

LOWER BOOT KIT COMPONENTS

CATALOG #	ITEM DESCRIPTION	SHIP WEIGHT		LIST PRICE
		LBS.	KG.	
720839	2.25" Single Outlet Basic Boot	15.2	6.9	
720849	2.25" Twin Outlet Basic Boot	26.0	11.8	
730839	3" 725 Pellet Auger Single Outlet Basic Boot	16.4	7.4	
730849	3" 725 Pellet Auger Twin Outlet Basic Boot	27.6	12.5	
730839	3" Single Outlet Basic Boot	16.4	7.4	
730849	3" Twin Outlet Basic Boot	27.6	12.5	
735839	3.5" Single Outlet Basic Boot	16.5	7.5	
735849	3.5" Twin Outlet Basic Boot	28.4	12.9	
500471	Boot Slide Valve - Single Plate	6.0	2.7	
500371	Boot Slide Valve - Twin/Split Plate	6.8	3.1	
720785	2.25" Anchor & Bearing	3.1	1.7	
731023	3" 725 Pellet Auger Anchor & Bearing	3.7	1.7	
731008	3" Anchor & Bearing	4.8	2.2	
735878	3.5" HV Anchor & Bearing	6.5	2.9	
735880	3.5" HM Anchor & Bearing	5.4	2.4	
720885	2.25" Pass-Thru Kit	2.5	1.1	
730885	3" 725 Pellet Auger Pass-Thru Kit	1.7	0.7	
730885	3" Pass-Thru Kit	1.7	0.7	
735885	3.5" Pass-Thru Kit	2.3	1.0	
730875	Single Boot Baffle/Restrictor	4.5	2.0	
730869	Twin Boot Baffle/Restrictor	3.3	1.5	

TO ORDER A COMPLETE LOWER BOOT BY COMPONENTS:

1. Select single or twin outlet basic boot.
2. Select single or twin slide valve.
3. Select anchor & bearing or pass-thru kit for each outlet of basic boot.
4. Select baffle/restrictor if pass-thru kit is used.
 Single Baffle for single outlet boot; twin baffle for twin boots (combination boots require twin baffle).

FLAG LINE & EXTENDED LENGTH SYSTEM ACCESSORIES

CATALOG #	ITEM DESCRIPTION	SHIP WEIGHT		LIST PRICE
		LBS.	KG.	
730760	Model 730 / 725 3" (75mm) Steel Outlet Box for Cross Fill Line	12.0	5.4	
735760	Model 735 3.5" (90mm) Steel Outlet Box for Cross Fill Line	12.5	5.7	
500517	Transfer Plate - For Steel Connects Steel Discharge Head or Poly Outlet Box to Lower Boot Less Slide Valve for flag line & extended length system applications.	3.1	1.4	
730780	Model 730 / 725 3" Poly Outlet Box for Cross Fill Line	9.0	4.1	
735780	Model 735 3.5" Poly Outlet Box for Cross Fill Line	9.5	4.3	
500590	Transfer Plate - For Poly (Galvanized Components) Connects Poly Discharge Head or Poly Outlet Box to Lower Boot Less Slide Valve for flag line & extended length system applications.	3.3	1.5	
501650	Transfer Plate - For Poly (Stainless Steel Components) Connects Poly Discharge Head or Steel Outlet Box to Lower Boot Less Slide Valve for flag line & extended length system applications.	3.2	1.4	
730085	Transfer Plate with Hole Alternative to outlet boxes & adapters above - use on Lower Boot Less Slide Valve to Receive from Discharge Head or Drop Outlet (Steel or	2.0	0.9	

Above outlet boxes used in conjunction with 500517/500590 Adapters (above) and Lower Boot Assembly Less Slide Valve (order separately from pages 04-04 & 04-05) to make complete flag system hopper. Or use 720550/730550/735550 All-Out Drop (order separately from pages 04-15 & 04-17) with 730085 Cover Plate with Hole used on Lower Boot Assembly Less Slide. Hopper switches are not included.



PVC TUBES & TUBE HANGERS

MODEL 720 - 2.25" PVC TUBES

CATALOG #	ITEM DESCRIPTION	SHIP WEIGHT		LIST PRICE
		LBS.	KG.	
720498	2.25" 45 Degree Formed PVC Tube	2.5	1.2	
720498-065	Bundle of 65 - 720498 Tubes	110.5	50.1	
720434	2.25" 10' Straight PVC Tube	6.0	2.7	
720434-270	Bundle of 270 - 720434 Tubes	1,108.0	502.6	
720435	2.25"PVC Tube Splice	0.3	0.1	
720435-070	Carton of 70 - 720435 Splices	21.0	9.5	

MODEL 725 / 730 - 3" PVC TUBES

CATALOG #	ITEM DESCRIPTION	SHIP WEIGHT		LIST PRICE
		LBS.	KG.	
730499	3" 45 Degree Formed PVC Tube	3.7	1.7	
730499-050	Bundle of 50 - 730499 Tubes	160.0	72.6	
730434	3" 10' Straight PVC Tube	9.0	4.1	
730434-116	Bundle of 116 - 730434 Tubes	858.4	389.4	
730435	3" PVC Tube Splice	0.5	0.2	
730435-080	Carton of 80 - 730435 Splices	32.0	14.5	

MODEL 735 - 3.5" PVC TUBES

CATALOG #	ITEM DESCRIPTION	SHIP WEIGHT		LIST PRICE
		LBS.	KG.	
735499	3.5" 45 Degree Formed PVC Tube	4.7	2.1	
735499-040	Bundle of 40 - 735499 Tubes	164.0	74.4	
735434	3.5" 10' Straight PVC Tube	10.0	4.5	
735434-108	Bundle of 108 - 735434 Tubes	893.0	405.1	
735435	3.5" PVC Tube Splice	0.6	0.2	
735435-050	Carton of 50 - 735435 Splices	25.0	11.3	

PVC CEMENT

CATALOG #	ITEM DESCRIPTION	SHIP WEIGHT		LIST PRICE
		LBS.	KG.	
730415	PVC Cement - 1/2 Pint	1.0	0.5	
VG125-QT	PVC Cement - Quart	2.0	0.9	

TUBE HANGING

CATALOG #	ITEM DESCRIPTION	SHIP WEIGHT		LIST PRICE
		LBS.	KG.	
720220	2.25" Formed Tube Hanger	0.3	0.1	
713220	3" Formed Tube Hanger - Galvanized	0.5	0.2	
713223	3" Formed Tube Hanger - 304SS	0.5	0.2	
735220	3.5" Formed Tube Hanger	0.6	0.3	
820099	#2 Hanger Chain Only - Per Foot	0.2	0.1	
VEN91507C	S Hook - 1/4" x 2.25"	0.1	0.033	
VEN91504C	5/16" x 3-1/2" Screw Hook	0.1	0.034	
713441	5/16" x 5" Screw Hook	0.1	0.045	

STEEL TUBES & CONNECTORS

MODEL 730 - 3"

CATALOG #	ITEM DESCRIPTION	SHIP WEIGHT		LIST PRICE
		LBS.	KG.	
730426	3" 45 Degree Steel Formed Elbow NO Bell (Coupler Required)	9.3	4.2	
730951	75MM(3") 10' Steel Tube NO Bell (Coupler Required)	12.0	5.4	
730952	75MM(3") Steel Tube Coupler-Requires 2 Clamps (sold Separately)	1.0	0.5	
730953	3" Tube Clamp	0.7	0.3	
730908	3" Steel to PVC Adapter (REF 990259 Quicksheet)	0.5	0.2	

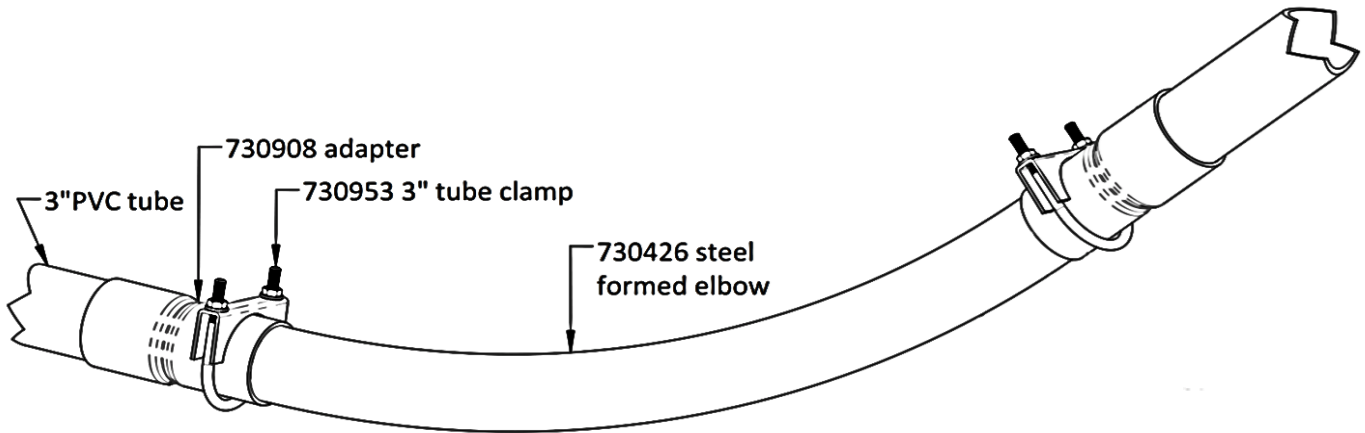

MODEL 735 - 3.5"

CATALOG #	ITEM DESCRIPTION	SHIP WEIGHT		LIST PRICE
		LBS.	KG.	
724401	3.5" Steel Tube Clamp (Requires 1 per straight tube)	0.8	0.4	
724402	4" U-bolt Clamp (for clamping PVC Bell/Splice to Steel Tube)	0.9	0.4	
735426	3.5" X 45 Degree Steel Tube with NO Bell (Coupler Required)	11.0	5.0	
735902	3.5" X 10' Steel Tube with Bell	25.0	72.6	
735904	3.5" Steel Tube Coupler with (2) Clamps	2.2	1.0	

735 tube can interchange between PVC and steel. Due to tight fitment, it may be required to cut slots in the belled end of PVC/PVC splice to fit overtop of the steel 735 tube. Use 724401 for clamping steel bell/coupler. Use 724402 for clamping the PVC bell/PVC splice."

FLEXIBLE AUGER

MODEL 720 FLEXIBLE AUGER		SHIP WEIGHT		LIST PRICE
		LBS.	KG.	
CATALOG #	ITEM DESCRIPTION			
720440-0040	40', 1.52" O.D. Auger - Model 720 Systems	20.8	9.4	
720440-0050	50', 1.52" O.D. Auger - Model 720 Systems	26.0	11.8	
720440-0060	60', 1.52" O.D. Auger - Model 720 Systems	31.2	14.2	
720440-0070	70', 1.52" O.D. Auger - Model 720 Systems	36.4	16.5	
720440-0080	80', 1.52" O.D. Auger - Model 720 Systems	41.6	18.9	
720440-0090	90', 1.52" O.D. Auger - Model 720 Systems	46.8	21.2	
720440-0100	100', 1.52" O.D. Auger - Model 720 Systems	52.0	23.6	
720440-0110	100', 1.52" O.D. Auger - Model 720 Systems	57.2	25.9	
720440-0120	120', 1.52" O.D. Auger - Model 720 Systems	62.4	28.3	
720440-0130	130', 1.52" O.D. Auger - Model 720 Systems	67.6	30.7	
720440-0140	140', 1.52" O.D. Auger - Model 720 Systems	72.8	33.0	
720440-0150	150', 1.52" O.D. Auger - Model 720 Systems	78.0	35.4	
720440-0160	160', 1.52" O.D. Auger - Model 720 Systems	83.2	37.7	
720440-0170	170', 1.52" O.D. Auger - Model 720 Systems	88.4	40.1	
720440-0180	180', 1.52" O.D. Auger - Model 720 Systems	93.6	42.5	
720440-0190	190', 1.52" O.D. Auger - Model 720 Systems	115.8	52.5	
720440-0200	200', 1.52" O.D. Auger - Model 720 Systems	104.0	47.2	
720440-0210	210', 1.52" O.D. Auger - Model 720 Systems	109.2	49.5	
720440-0220	220', 1.52" O.D. Auger - Model 720 Systems	114.4	51.9	
720440-0230	230', 1.52" O.D. Auger - Model 720 Systems	119.6	54.3	
720440-0240	240', 1.52" O.D. Auger - Model 720 Systems	124.8	56.6	
720440-0250	250', 1.52" O.D. Auger - Model 720 Systems	130.0	59.0	
720440-0260	260', 1.52" O.D. Auger - Model 720 Systems	135.2		
720440-0270	270', 1.52" O.D. Auger - Model 720 Systems	140.4	63.7	
720440-0280	280', 1.52" O.D. Auger - Model 720 Systems	145.6	66.0	
720440-0290	290', 1.52" O.D. Auger - Model 720 Systems	150.8	68.4	
720440-0300	300', 1.52" O.D. Auger - Model 720 Systems	160.0	72.6	
720440-0400	400', 1.52" O.D. Auger - Model 720 Systems	220.0	99.8	
720440-1500	Skid of 5 - 300' Rolls of 720440 Auger	780.0	353.8	
720440-3000	Flexible Auger, 1.52OD, 3000 FT On Reel	1,600.0	725.8	
720440-5000	Flexible Auger, 1.52OD, 5000 FT On Reel	2,675.0	1213.4	

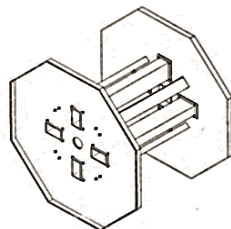

AUGER REEL NOTES

3000 & 5000 feet of 1.52 OD auger shipped on reel.

Price includes the auger reel.

Auger reels will be credited \$550 upon return in **good** condition.

FLEXIBLE AUGER

MODEL 725 "PELLET" FLEXIBLE AUGER		SHIP WEIGHT		LIST PRICE
		LBS.	KG.	
CATALOG #	ITEM DESCRIPTION			
725440-0040	40' 2.25" O.D. Auger - Model 725 Systems	41.2	18.7	
725440-0050	50' 2.25" O.D. Auger - Model 725 Systems	51.5	23.4	
725440-0060	60' 2.25" O.D. Auger - Model 725 Systems	61.8	28.0	
725440-0070	70' 2.25" O.D. Auger - Model 725 Systems	72.1	32.7	
725440-0080	80' 2.25" O.D. Auger - Model 725 Systems	82.4	37.4	
725440-0090	90' 2.25" O.D. Auger - Model 725 Systems	92.7	42.0	
725440-0100	100' 2.25" O.D. Auger - Model 725 Systems	103.0	46.7	
725440-0110	110' 2.25" O.D. Auger - Model 725 Systems	113.3	51.4	
725440-0120	120' 2.25" O.D. Auger - Model 725 Systems	123.6	56.1	
725440-0130	130' 2.25" O.D. Auger - Model 725 Systems	133.9	60.7	
725440-0140	140' 2.25" O.D. Auger - Model 725 Systems	144.2	65.4	
725440-0150	150' 2.25" O.D. Auger - Model 725 Systems	154.5	70.1	
725440-0160	160' 2.25" O.D. Auger - Model 725 Systems	164.8	74.8	
725440-0170	170' 2.25" O.D. Auger - Model 725 Systems	175.1	79.4	
725440-0180	180' 2.25" O.D. Auger - Model 725 Systems	185.0	83.9	
725440-0190	190' 2.25" O.D. Auger - Model 725 Systems	195.7	88.8	
725440-0200	200' 2.25" O.D. Auger - Model 725 Systems	206.0	93.4	
725440-0210	210' 2.25" O.D. Auger - Model 725 Systems	216.3	98.1	
725440-0220	220' 2.25" O.D. Auger - Model 725 Systems	226.6	102.8	
725440-0230	230' 2.25" O.D. Auger - Model 725 Systems	236.9	107.5	
725440-0240	240' 2.25" O.D. Auger - Model 725 Systems	247.2	112.1	
725440-0250	250' 2.25" O.D. Auger - Model 725 Systems	257.5	116.8	
725440-0260	260' 2.25" O.D. Auger - Model 725 Systems	267.8	121.5	
725440-0270	270' 2.25" O.D. Auger - Model 725 Systems	278.1	126.1	
725440-0280	280' 2.25" O.D. Auger - Model 725 Systems	288.4	130.8	
725440-0290	290' 2.25" O.D. Auger - Model 725 Systems	298.7	135.5	
725440-0300	300' 2.25" O.D. Auger - Model 725 Systems	309.0	140.2	
725440-1500	Skid of 5 - 300' Rolls of 720440 Auger	1,542.0	699.5	
725440-2100	Skid of 7 - 300' Rolls of 720440 Auger	2,215.0	1004.7	
725440-3000	Flexible Auger, 2.25OD, 3000 Ft On Reel	3,090.0	1401.6	

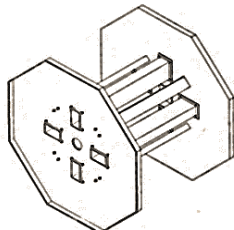

AUGER REEL NOTES

3000 feet of 1.52 OD auger shipped on reel.

Price includes the auger reel.

Auger reels will be credited \$550 upon return in **good** condition.

FLEXIBLE AUGER

MODEL 730 FLEXIBLE AUGER

CATALOG #	ITEM DESCRIPTION	SHIP WEIGHT		LIST PRICE
		LBS.	KG.	
730440-0040	40' 2.38" O.D. Auger - Model 730 and Model 735HM Systems	39.2	17.8	
730440-0050	50' 2.38" O.D. Auger - Model 730 and Model 735HM Systems	49.0	22.2	
730440-0060	60' 2.38" O.D. Auger - Model 730 and Model 735HM Systems	58.8	26.7	
730440-0070	70' 2.38" O.D. Auger - Model 730 and Model 735HM Systems	68.6	31.1	
730440-0080	80' 2.38" O.D. Auger - Model 730 and Model 735HM Systems	78.4	35.6	
730440-0090	90' 2.38" O.D. Auger - Model 730 and Model 735HM Systems	88.2	40.0	
730440-0100	100' 2.38" O.D. Auger - Model 730 and Model 735HM Systems	98.0	44.5	
730440-0110	110' 2.38" O.D. Auger - Model 730 and Model 735HM Systems	107.8	48.9	
730440-0120	120' 2.38" O.D. Auger - Model 730 and Model 735HM Systems	118.0	53.5	
730440-0130	130' 2.38" O.D. Auger - Model 730 and Model 735HM Systems	127.4	57.8	
730440-0140	140' 2.38" O.D. Auger - Model 730 and Model 735HM Systems	137.2	62.2	
730440-0150	150' 2.38" O.D. Auger - Model 730 and Model 735HM Systems	147.0	66.7	
730440-0160	160' 2.38" O.D. Auger - Model 730 and Model 735HM Systems	156.8	71.1	
730440-0170	170' 2.38" O.D. Auger - Model 730 and Model 735HM Systems	166.6	75.6	
730440-0180	180' 2.38" O.D. Auger - Model 730 and Model 735HM Systems	176.4	80.0	
730440-0190	190' 2.38" O.D. Auger - Model 730 and Model 735HM Systems	186.2	84.5	
730440-0200	200' 2.38" O.D. Auger - Model 730 and Model 735HM Systems	183.1	83.1	
730440-0210	210' 2.38" O.D. Auger - Model 730 and Model 735HM Systems	205.8	93.4	
730440-0220	220' 2.38" O.D. Auger - Model 730 and Model 735HM Systems	215.6	97.8	
730440-0230	230' 2.38" O.D. Auger - Model 730 and Model 735HM Systems	225.4	102.2	
730440-0240	240' 2.38" O.D. Auger - Model 730 and Model 735HM Systems	235.2	106.7	
730440-0250	250' 2.38" O.D. Auger - Model 730 and Model 735HM Systems	245.0	111.1	
730440-0260	260' 2.38" O.D. Auger - Model 730 and Model 735HM Systems	254.8	115.6	
730440-0270	270' 2.38" O.D. Auger - Model 730 and Model 735HM Systems	264.6	120.0	
730440-0280	280' 2.38" O.D. Auger - Model 730 and Model 735HM Systems	274.4	124.5	
730440-0290	290' 2.38" O.D. Auger - Model 730 and Model 735HM Systems	284.2	128.9	
730440-0300	300' 2.38" O.D. Auger - Model 730 and Model 735HM Systems	290.0	131.5	
730440-1500	Skid of 5 - 300' Rolls of 730440 Auger	1,490.0	675.9	
730440-2100	Skid of 7 - 300' Rolls of 730440 Auger	2,090.0	948.0	
730440-2700	Flexible Auger, 2.38 OD, 2700 Ft On Reel	2,646.0	1200.2	
730440-3000	Flexible Auger, 2.38 OD, 3000 Ft On Reel	2,910.0	1320.0	

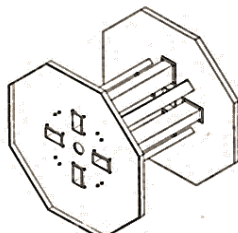

AUGER REEL NOTES

3000 feet of 2.38 OD auger shipped on reel.

Price includes the auger reel.

Auger reels will be credited \$550 upon return in **good** condition.

FLEXIBLE AUGER

MODEL 735 FLEXIBLE AUGER

CATALOG #	ITEM DESCRIPTION	SHIP WEIGHT		LIST PRICE
		LBS.	KG.	
735440-0040	40' 2.71" O.D. Auger - Model 735HV Systems	35.2	16.0	
735440-0050	50' 2.71" O.D. Auger - Model 735HV Systems	44.0	20.0	
735440-0060	60' 2.71" O.D. Auger - Model 735HV Systems	52.8	24.0	
735440-0070	70' 2.71" O.D. Auger - Model 735HV Systems	61.6	27.9	
735440-0080	80' 2.71" O.D. Auger - Model 735HV Systems	75.0	34.0	
735440-0090	90' 2.71" O.D. Auger - Model 735HV Systems	79.2	35.9	
735440-0100	100' 2.71" O.D. Auger - Model 735HV Systems	88.0	39.9	
735440-0110	110' 2.71" O.D. Auger - Model 735HV Systems	96.8	43.9	
735440-0120	120' 2.71" O.D. Auger - Model 735HV Systems	106.0	48.1	
735440-0130	130' 2.71" O.D. Auger - Model 735HV Systems	114.4	51.9	
735440-0140	140' 2.71" O.D. Auger - Model 735HV Systems	123.2	55.9	
735440-0150	150' 2.71" O.D. Auger - Model 735HV Systems	132.0	59.9	
735440-0160	160' 2.71" O.D. Auger - Model 735HV Systems	140.8	63.9	
735440-0170	170' 2.71" O.D. Auger - Model 735HV Systems	149.6	67.9	
735440-0180	180' 2.71" O.D. Auger - Model 735HV Systems	158.4	71.9	
735440-0190	190' 2.71" O.D. Auger - Model 735HV Systems	167.2	75.8	
735440-0200	200' 2.71" O.D. Auger - Model 735HV Systems	176.0	79.8	
735440-0210	210' 2.71" O.D. Auger - Model 735HV Systems	184.8	83.8	
735440-0220	220' 2.71" O.D. Auger - Model 735HV Systems	193.6	87.8	
735440-0230	230' 2.71" O.D. Auger - Model 735HV Systems	202.4	91.8	
735440-0240	240' 2.71" O.D. Auger - Model 735HV Systems	211.1	95.8	
735440-0250	250' 2.71" O.D. Auger - Model 735HV Systems	220.0	99.8	
735440-0260	260' 2.71" O.D. Auger - Model 735HV Systems	228.8	103.8	
735440-0270	270' 2.71" O.D. Auger - Model 735HV Systems	237.6	107.8	
735440-0280	280' 2.71" O.D. Auger - Model 735HV Systems	246.4	111.8	
735440-0290	290' 2.71" O.D. Auger - Model 735HV Systems	255.2	115.8	
735440-0300	300' 2.71 O.D. Auger - Model 735HV Systems	264.0	119.8	
735440-1500	Skid of 5 - 300' Rolls of 735440 Auger	1,365.0	619.2	
735440-2100	Skid of 7 - 300' Rolls of 735440 Auger	1,910.0	866.4	
735440-2700	Flexible Auger, 2.71 OD, 2700 Ft On Reel	2,700.0	1224.7	

MODEL 735 - 3.5" STEEL TUBES (Typically used for layer feed.)

735426	3.5" 45 Degree Steel Elbow	11.0	5.0	
735902	3.5" 10' Straight Steel Tube	25.0	11.3	
735904	3.5" Steel Tube Coupler with Clamps	2.2	1.0	
724401	3.5" Steel Tube Clamp (1 required for each straight tube)	0.8	0.4	

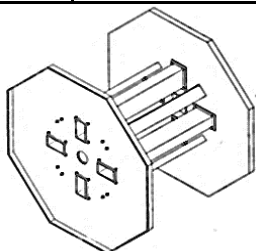

AUGER REEL NOTES

2700 feet of 2.71 OD auger shipped on reel.

Price includes the auger reel.

Auger reels will be credited \$550 upon return in **good** condition.



MODEL 720/725/730 DROP OUTLETS & DOWNSPOUT TUBES

MODEL 720 - 2.25" DROP OUTLETS

CATALOG #	ITEM DESCRIPTION	SHIP WEIGHT		LIST PRICE
		LBS.	KG.	
720550	2.25" All-Out Poly Drop with Shutoff	1.3	0.6	
720555	Carton of 10 - 720550 All-Out Poly Drops	9.0	4.1	

MODEL 725 / 730 - 3" DROP OUTLETS

CATALOG #	ITEM DESCRIPTION	SHIP WEIGHT		LIST PRICE
		LBS.	KG.	
730550	3" All-Out Poly Drop with Shutoff	1.3	0.6	
730555	Carton of 10 - 730550 All-Out Poly Drops	9.0	4.1	

MODEL 720 / 725 / 730 DOWNSPOUT TUBES & ACCESSORIES

CATALOG #	ITEM DESCRIPTION	SHIP WEIGHT		LIST PRICE
		LBS.	KG.	
730615	3" I.D. x 12' Translucent Plastic Downspout Tube	3.8	1.4	
730289	3.25" I.D. x 12' Telescoping Plastic Downspout Tube	4.0	1.8	
730480	3" I.D. Flexible Rubber Downspout Tube - 25' Length	14.8	6.7	
730449	3" I.D. Flexible Rubber Downspout Tube - 18" (46cm)	0.4	0.2	
730201	Drop Tube Wire Clip	0.1	0.0	
730431	3" Stainless Steel Downspout Clamp	0.1	0.0	
730437	3" Plastic Y Fitting for Downspout Tube	0.4	0.2	
730438	3" Plastic 45 Degree Fitting for Downspout Tube	0.2	0.1	
730439	3" Downspout Sleeve Connector	0.1	0.0	
690291	TEK Screw #10 - 16 X 3/4	0.0	0.0	
730485	3" Downspout SurFit Adapter	0.1	0.0	

For more information on drop outlet components see page 04-15

MODEL 720/730 DROP OUTLETS & DOWNSPOUT TUBES

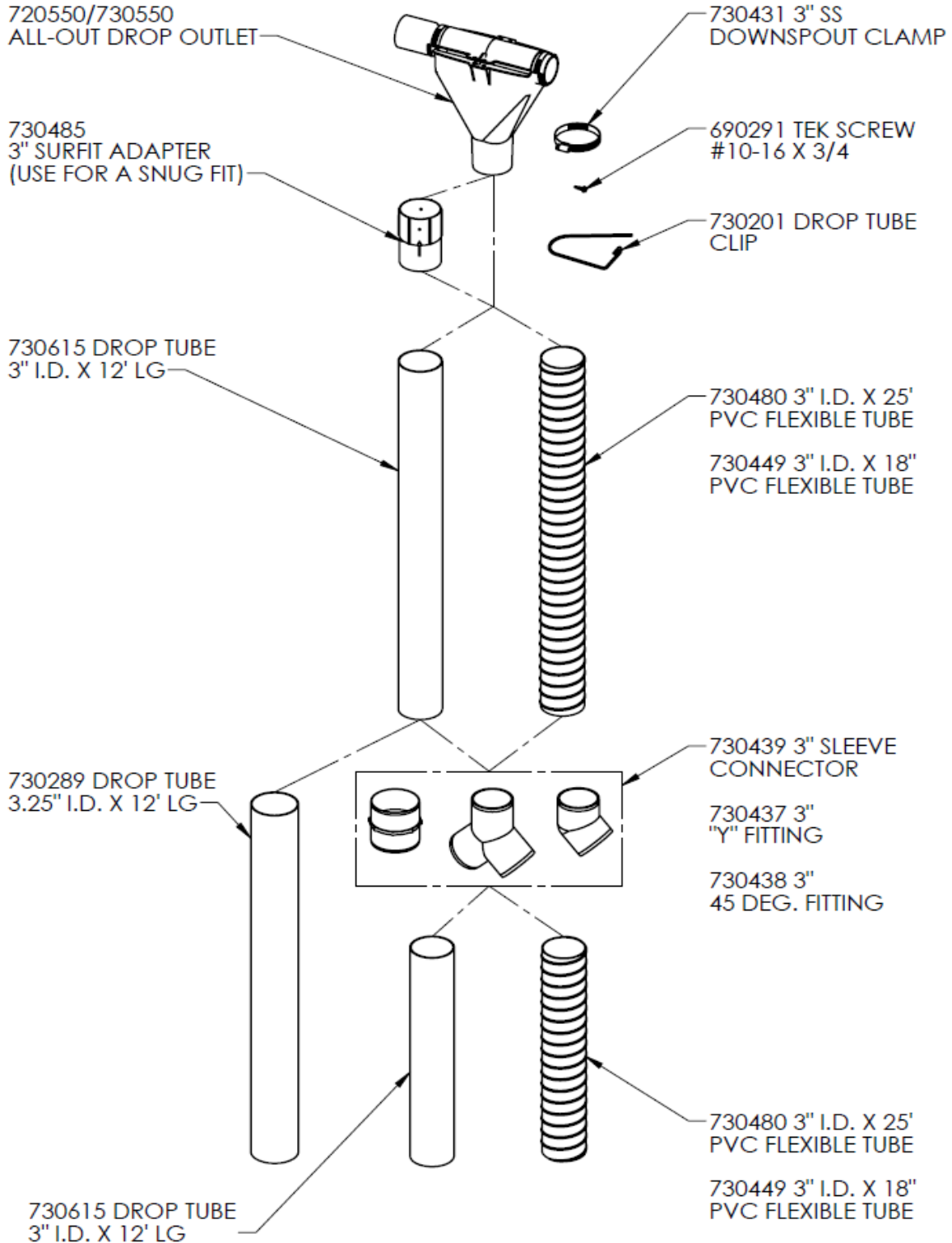

990102 MOD 720_730 DROP OUTLETS
ECO 12428 - REV A

See page 04-14 for drop tube pricing



MODEL 735 DROP OUTLETS & DOWNSPOUT TUBES

MODEL 735 - 3.5" DROP OUTLETS

CATALOG #	ITEM DESCRIPTION	SHIP WEIGHT		LIST PRICE
		LBS.	KG.	
735550	3.5" All-Out Poly Drop with Shutoff	1.3	0.6	
735555	Carton of 10 - 735550 All-Out Poly Drops	9.7	4.4	

MODEL 735 DOWNSPOUT TUBES & ACCESSORIES

CATALOG #	ITEM DESCRIPTION	SHIP WEIGHT		LIST PRICE
		LBS.	KG.	
735485	3.5" Sur-Fit Adapter (Use for snug fit)	0.1	0.1	
735615	3.5" I.D. x 12' Translucent Plastic Downspout Tube	4.0	1.8	
735289	3.75" I.D. x 12' Telescoping Translucent Plastic Downspout Tube	4.4	2.0	
735680	3.5" I.D. x 25' Length Roll Flexible PVC Downspout Tube	13.3	6.0	
735682	3.5" I.D. Flexible PVC Downspout Tube - 18" (46cm)	0.6	0.3	
735439	3.5" Downspout Sleeve Connector	0.1	0.1	
690291	TEK Screw #10 - 16 X 3/4	0.0	0.0	
730201	Drop Tube Wire Clip	0.1	0.0	
735431	3.5" Stainless Steel Downspout Clamp	0.1	0.0	

For more information on drop outlet components see page 04-17

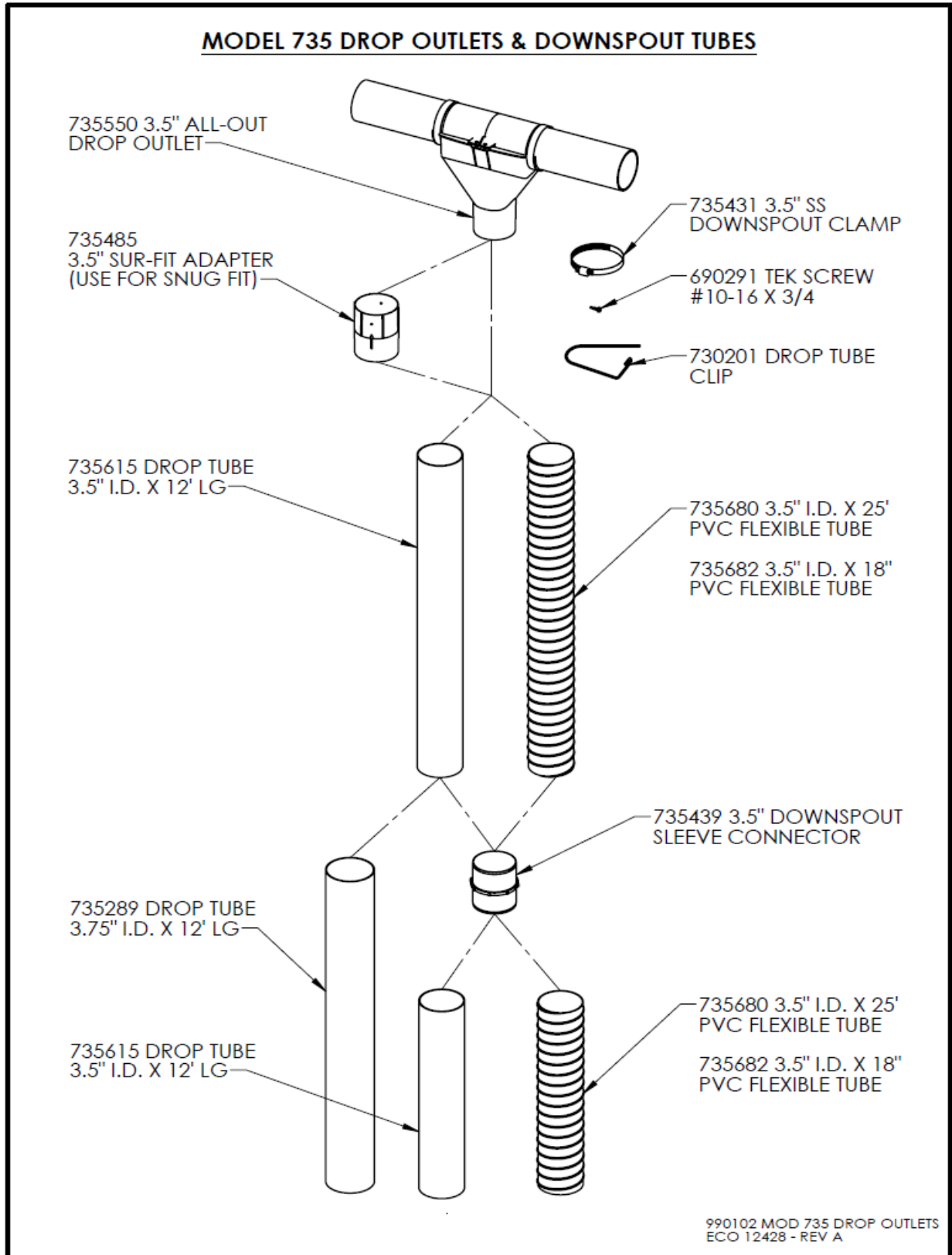

See page 04-16 for drop tube pricing



DISCHARGE HEADS

TO ORDER A COMPLETE DRIVE UNIT

DIRECT DRIVE UNIT

Order a steel (below) or poly (page 04-20 thru 04-22) discharge head kit and port & driver kit from page 04-23. Also order a direct drive motor & gearbox unit from pages 04-24 thru 04-25.

V-BELT DRIVE UNIT

Order a steel discharge head kit below (do NOT use poly head). Order v-belt drive unit (page 04-25) & a farm duty motor from catalog section 20.

Order port & driver kit from page 04-23.

STEEL DISCHARGE HEAD KITS

CATALOG #	ITEM DESCRIPTION	SHIP WEIGHT		LIST PRICE
		LBS.	KG.	
SINGLE PHASE	730531 Steel Discharge Head Kit - Relay Control - For use in 1PH applications only - Shipped in two cartons: (1) 730462 Basic Steel Head (1) 730501 Control Box - 1PH Motor Relay included	6.5	2.9	
	730731 Stainless Steel Discharge Head Kit - Relay Control	8.3	3.7	
	730532 Steel Discharge Head Kit - Relay Control & Proximity Sensor - For use in 1PH applications only - Shipped in three cartons: (1) 730462 Basic Steel Head (1) 730501 Control Box - 1PH Motor Relay included (1) 730465 Proximity Sensor	7.7	3.5	
	730732 Stainless Steel Discharge Head Kit - Relay Control & Prox. Sensor	8.7	3.9	
3-PHASE or SINGLE PHASE	730533 Steel Discharge Head Kit - Basic Control - For use in 1 or 3PH phase applications - Shipped in two cartons: (1) 730462 Basic Steel Head (1) 730505 Control Box - Motor Relay Not Included	6.5	2.9	
	730733 Stainless Steel Discharge Head Kit - Basic Control	8.1	3.7	
	730534 Steel Discharge Head Kit - Basic Unit & Proximity Sensor - For use in 1 or 3PH applications - Shipped in three cartons: (1) 730462 Basic Steel Head (1) 730505 Control Box - Motor Relay Not Included (1) 730465 Proximity Sensor	7.7	3.5	
	730734 Stainless Steel Discharge Head Kit - Basic Unit & Proximity Sensor	8.5	3.9	

Mechanical back-up safety switch is included with all control options.

Proximity or mechanical feed level sensing may be used with all controls.

- See catalog section 04-26 for feed level sensing options

Customer must provide motor relay for all basic controls

See page 04-22 for more details on the steel discharge head

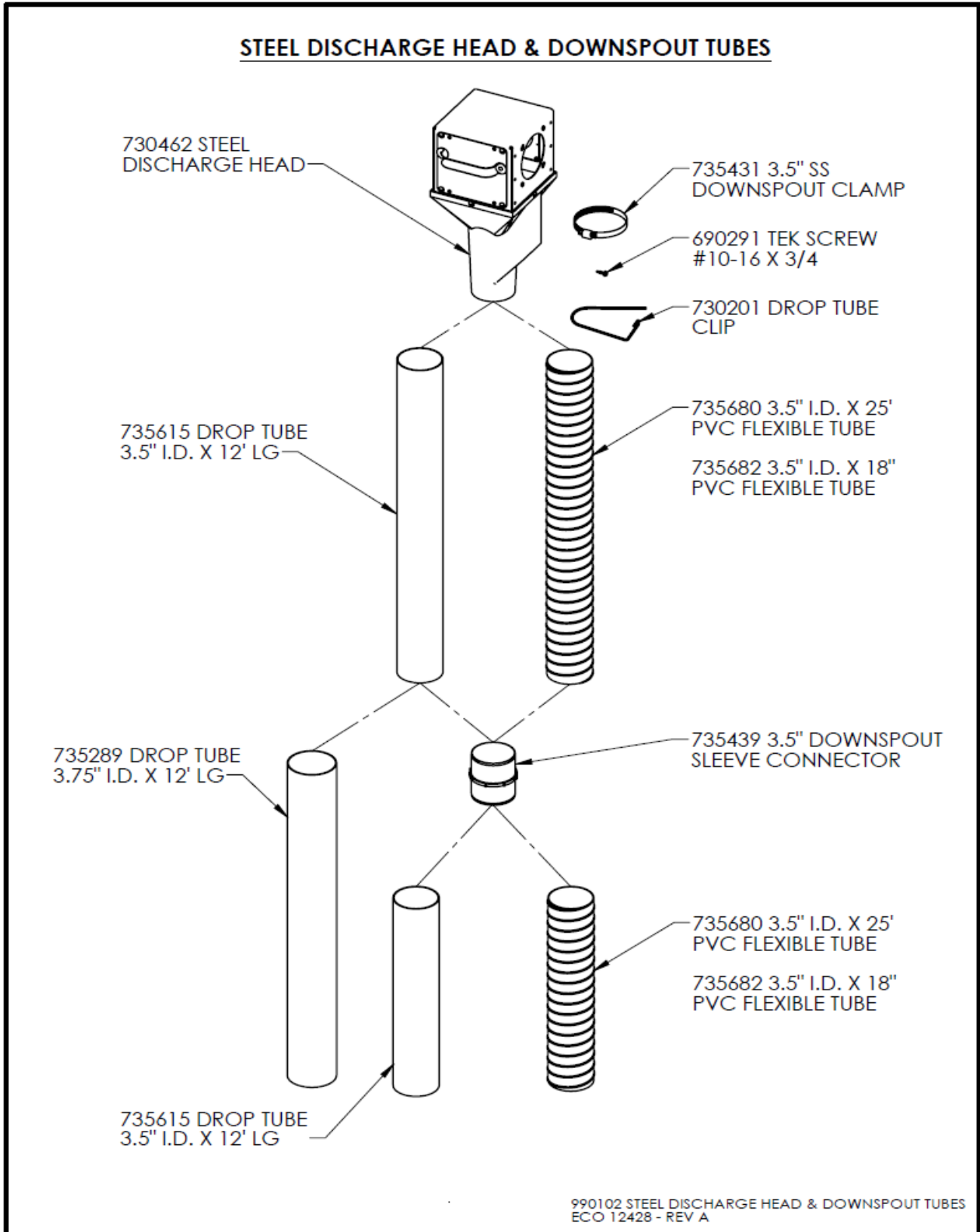

See page 04-16 for drop tube pricing

DISCHARGE HEADS

POLY DISCHARGE HEAD KITS

Metal components will be Steel (Galv.) or Stainless Steel (SS)

CATALOG #		ITEM DESCRIPTION		SHIP WEIGHT		LIST PRICE
				LBS.	KG.	
SINGLE PHASE	730538	Galv.	Poly Discharge Head Kit - Basic Control - For use in 1 or 3PH applications - Shipped in two cartons: (1) 730463 Basic Poly Head (Galv.) or (1) 730575 Basic Poly Head (SS) (1) 730501 Control Box - Motor Relay Not Included	7.1	3.2	
	730578	SS		6.3	2.9	
	730539	Galv.	Poly Discharge Head Kit - Basic Unit & Proximity Sensor - For use in 1 or 3PH applications - Shipped in three cartons: (1) 730463 Basic Poly Head (Galv.) or (1) 730575 Basic Poly Head (SS) (1) 730505 Control Box - Motor Relay Not Included (1) 730465 Proximity Sensor	8.3	3.8	
	730579	SS		6.7	3.0	
	730536	Galv.	Poly Discharge Head Kit - Relay Control - For use in 1PH applications only - Shipped in two cartons: (1) 730463 Basic Poly Head (Galv.) or (1) 730575 Basic Poly Head (SS) (1) 730501 Control Box - 1PH Motor Relay included	7.1	3.2	
	730576	SS		6.5	2.9	
	730537	Galv.	Poly Discharge Head Kit - Relay Control & Proximity Sensor - For use in 1PH applications only - Shipped in three cartons: (1) 730463 Basic Poly Head (Galv.) or (1) 730575 Basic Poly Head (SS) (1) 730501 Control Box - 1PH Motor Relay included (1) 730465 Proximity Sensor	8.3	3.8	
	730577	SS		6.9	3.1	
3-PHASE	730538	Galv.	Poly Discharge Head Kit - Basic Control - For use in 1 or 3PH phase applications - Shipped in two cartons: (1) 730463 Basic Poly Head (Galv.) or (1) 730575 Basic Poly Head (SS) (1) 730505 Control Box - Motor Relay Not Included	7.1	3.2	
	730578	SS		6.3	2.9	
	730539	Galv.	Poly Discharge Head Kit - Basic Unit & Proximity Sensor - For use in 1 or 3PH applications - Shipped in three cartons: (1) 730463 Basic Poly Head (Galv.) or (1) 730575 Basic Poly Head (SS) (1) 730505 Control Box - Motor Relay Not Included (1) 730465 Proximity Sensor	8.3	3.8	
	730579	SS		6.7	3.0	

Mechanical back-up safety switch is included with all control options.

Proximity or mechanical feed level sensing may be used with all controls.

- See catalog section 04-26 for feed level sensing options

Customer must provide motor relay for all basic controls

See page 04-22 for more details on the poly discharge head

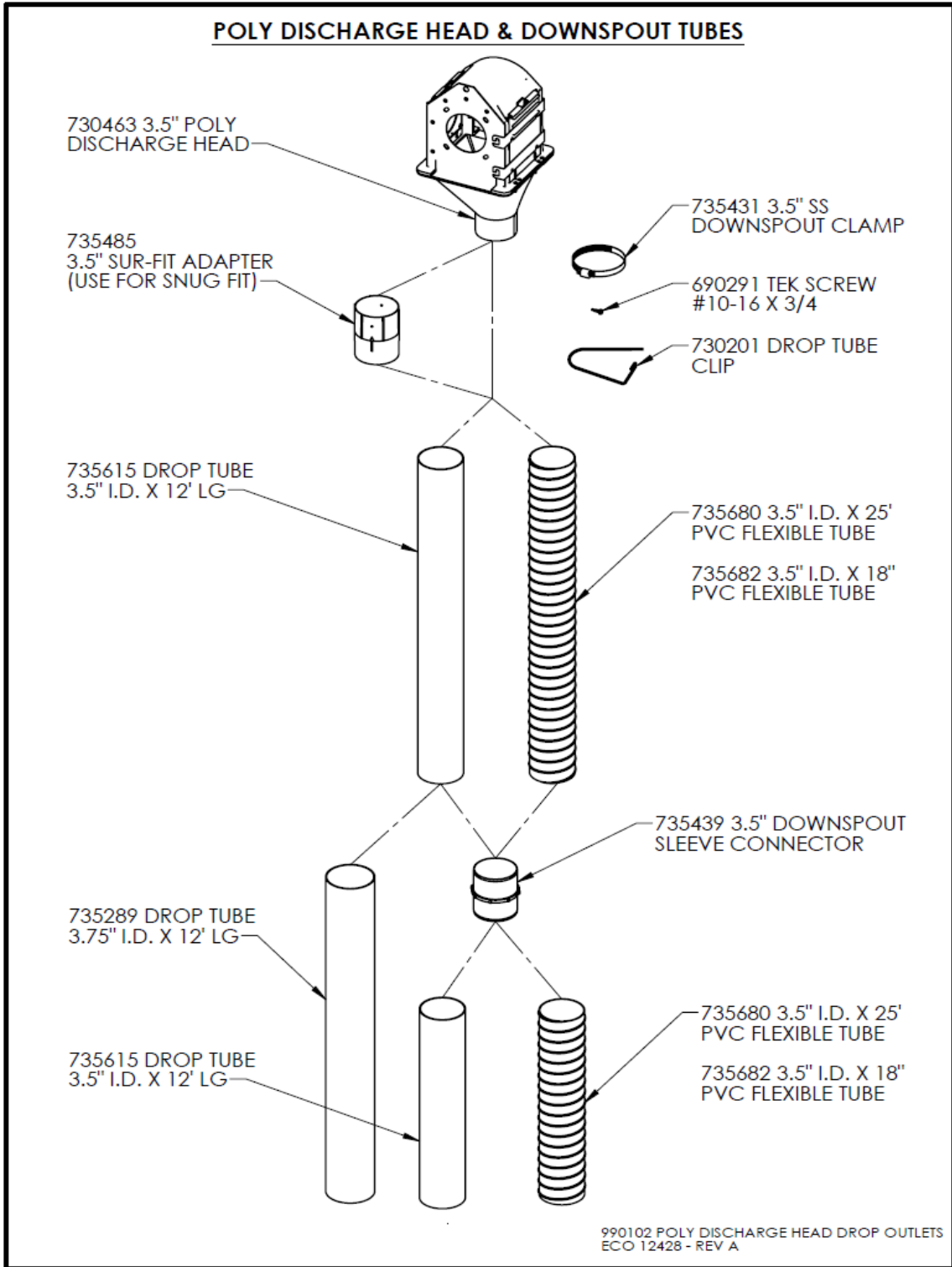

See page 04-16 for drop tube pricing



DISCHARGE HEADS

DISCHARGE HEAD KIT COMPONENT REQUIREMENTS COMPONENT → CATALOG NUMBER & DESCRIPTION →		KIT COMPONENTS & QUANTITY REQUIRED					
		BASIC DISCHARGE HEAD			ELECTRICAL CONTROL BOX		PROXIMITY SENSOR
		730462 Basic Steel Head	730463 Basic Poly Head (Galv.)	730575 Basic Poly Head (SS)	730505 1 or 3 Phase No Relay	730501 1 Phase with Relay	730465 Proximity Switch with Mount
CATALOG # OF DH KIT	DESCRIPTION OF DISCHARGE HEAD KIT	QUANTITY REQUIRED					
STEEL DISCHARGE HEAD KITS							
730533	D.H., Basic Control	1			1		
730534	D.H., Basic Control, Prox. Sensor	1			1		1
730531	D.H., Relay Control	1				1	
730532	D.H., Relay Control, Prox. Sensor	1				1	1
POLY DISCHARGE HEAD KITS (Galv.)							
730538	D.H., Basic Control		1		1		
730539	D.H., Basic Control, Prox. Sensor		1		1		1
730536	D.H., Relay Control		1			1	
730537	D.H., Relay Control, Prox. Sensor		1			1	1
POLY DISCHARGE HEAD KITS (SS)							
730578	D.H., Basic Control			1	1		
730579	D.H., Basic Control, Prox. Sensor			1	1		1
730576	D.H., Relay Control			1		1	
730577	D.H., Relay Control, Prox. Sensor			1		1	1

DISCHARGE HEAD KIT COMPONENTS

CATALOG #	ITEM DESCRIPTION	SHIP WEIGHT		LIST PRICE
		LBS.	KG.	
730462	Basic Steel Discharge Head	7.8	3.5	
730463	Basic Poly Discharge Head (Galvanized Components)	5.4	2.4	
730575	Basic Poly Discharge Head (Stainless Steel Components)	4.1	1.9	
730750	Basic Stainless Steel Discharge Head	6.5	2.9	
730486	Discharge Head - Gasket Replacement Kit	1.3	0.6	
730505	Basic Control Box - Motor Relay Not Included - For Single or Three Phase Applications	2.3	1.0	
730501	Relay Control Box - 1PH Motor Relay Included - For Single Phase Applications Only	2.6	1.2	
731040	Relay Control Box with AP Discharge Head Mounting Plate Adapter Kit - 1PH Motor Relay Included - For Single Phase Applications Only	3.3	1.5	
730465	Proximity Switch with Mount & Hardware	0.9	0.4	

PORT & DRIVER KITS

FOR STEEL DISCHARGE HEAD

PORT & DRIVER KITS FOR STEEL DISCHARGE HEAD FOR DIRECT DRIVE WITH 7/8" OUTPUT SHAFT

CATALOG #	ITEM DESCRIPTION	SHIP WEIGHT		LIST PRICE
		LBS.	KG.	
720304	2.25" Port & Driver Kit for Direct Drive Unit - 7/8" Bore Driver	3.4	1.6	
725304	3" Port & 725 Driver Kit for Direct Drive Unit - 7/8" Bore Driver	3.8	1.7	
725320	3" Port & 725 Driver Kit for Direct Drive Unit SS - 7/8" Bore Driver	3.5	1.6	
730304	3" Port & Driver Kit for Direct Drive Unit - 7/8" Bore Driver	3.6	1.6	
731035	3" Port & Driver Kit for Direct Drive Unit Stainless Steel - 7/8" Bore Driver	4.2	1.9	
735305	3.5" HV Port & Driver Kit for Direct Drive Unit - 7/8" Bore Driver	4.9	2.2	
735304	3.5" HM Port & Driver Kit for Direct Drive Unit - 7/8" Bore Driver	3.9	1.8	

PORT & DRIVER KITS FOR STEEL DISCHARGE HEAD FOR BELT DRIVE WITH 5/8" OUTPUT SHAFT

CATALOG #	ITEM DESCRIPTION	SHIP WEIGHT		LIST PRICE
		LBS.	KG.	
720049	2.25" Port & Driver Kit - 5/8" Bore Driver	2.1	1.0	
730050	3" Port & Driver Kit - 5/8" Bore Driver	3.7	1.7	
735049	3.5" HV Port & Driver Kit - 5/8" Bore Driver	5.1	2.3	
735100	3.5" HM Port & Driver Kit - 5/8" Bore Driver	4.1	1.9	

FOR POLY DISCHARGE HEAD

PORT & DRIVER KITS FOR POLY DISCHARGE HEAD FOR DIRECT DRIVE WITH 7/8" OUTPUT SHAFT

CATALOG #	ITEM DESCRIPTION	SHIP WEIGHT		LIST PRICE
		LBS.	KG.	
720464	2.25" Port & Driver Kit for Direct Drive Unit - 7/8" Bore Driver	2.8	1.3	
725464	3" Port & 725 Driver Kit for Direct Drive Unit - 7/8" Bore Driver	3.3	1.5	
730464	3" Port & Driver Kit for Direct Drive Unit - 7/8" Bore Driver	3.0	1.4	
735466	3.5" HV Port & Driver Kit for Direct Drive Unit - 7/8" Bore Driver	4.5	2.0	
735480	3.5" HM Port & Driver Kit for Direct Drive Unit - 7/8" Bore Driver	3.5	1.6	

DIRECT DRIVE MOTOR AND GEARBOXES

1 PHASE - 7/8" OUTPUT SHAFTS

Electrical Info		115V, 50HZ, 1PH	115V, 60HZ, 1PH	230V, 50HZ, 1PH	230V, 60HZ, 1PH	OUTPUT SPEED (50/60HZ) -->	GEARBOX -->	Drive Output RPMs are approximate based on motor RPMs of 1425 @ 50Hz and 1725 @ 60 Hz. (Actual Output RPM's may vary)
		VOLTS	115	115	230			
HERTZ		50	60	50	60			
PHASE		1	1	1	1			
HP	0.50	720325	720325	720325	720325	156/189	730123	
	0.75	720326	720326	720326	720326			
	1.0	720327	720327	720327	720327			
	1.5		720328		720328			
HP	0.50	730315	730315	730315	730315	220/266	730093	
	0.75	730316	730316	730316	730316			
	1.0	735532	730317	735532	730317			
	1.5	735533	730318	735533	730318			
HP	0.50	735380	735380	735380	735380	296/359	730089	
	0.75	735381	735381	735381	735381			
	1.0	735527	735382	735527	735382			
	1.5	735528	735383	735528	735383			
HP	0.50	735360	735360	735360	735360	365/441	730124	
	0.75	735361	735361	735361	735361			
	1.0	735342	735362	735342	735362			
	1.5	735343	735363	735343	735363			

For pricing, see page 04-25

More electrical options and speeds are available upon request

DIRECT DRIVE MOTOR AND GEARBOXES

3 PHASE - 7/8" OUTPUT SHAFTS

Electrical Info		230V, 60HZ, 3PH	460V, 60HZ, 3PH	190V, 50HZ, 3PH	380V, 50HZ, 3PH	OUTPUT SPEED (50/60HZ) -->	GEARBOX -->	Drive Output RPMs are approximate based on motor RPMs of 1425 @ 50Hz and 1725 @ 60 Hz. (Actual Output RPM's may vary)
		VOLTS	230	460	190			
HERTZ		60	60	50	50			
PHASE		3	3	3	3			
HP	0.50	735520	735520	735520	735520	156/189	730123	
	0.75	735521	735521	735521	735521			
	1.0	735522	735522	735522	735522			
	1.5	735523	735523	735523	735523			
HP	0.50	735515	735515	735515	735515	220/266	730093	
	0.75	735516	735516	735516	735516			
	1.0	735517	735517	735517	735517			
	1.5	735518	735518	735518	735518			
HP	0.50	735330	735330	735330	735330	296/359	730089	
	0.75	735331	735331	735331	735331			
	1.0	735332	735332	735332	735332			
	1.5	735333	735333	735333	735333			
HP	0.50	735510	735510	735510	735510	365/441	730124	
	0.75	735511	735511	735511	735511			
	1.0	735512	735512	735512	735512			
	1.5	735513	735513	735513	735513			

For pricing, see page 04-25

More electrical options and speeds are available upon request



DIRECT DRIVE MOTOR & GEARBOX UNITS - 7/8" OUTPUT SHAFT

CATALOG #	ITEM DESCRIPTION	SHIP WEIGHT		LIST PRICE
		LBS.	KG.	
720325	DRIVE, .50HP,156/189RPM,7/8SH,115/230V,50/60H,1P	50.0	22.7	
720326	DRIVE, .75HP,156/189RPM,7/8SH,115/230V,50/60H,1P	53.0	24.0	
720327	DRIVE,1.0HP,189RPM,7/8SH,115/208-230V,60H,1P	58.5	26.5	
720328	DRIVE,1.5HP,189RPM,7/8SH,115/230V,60H,1P	80.0	36.3	
730315	DRIVE, .50HP,220/266RPM,7/8SH,115/230V,50/60H,1P	50.0	22.7	
730316	DRIVE, .75HP,220/266RPM,7/8SH,115/230V,50/60H,1P	42.1	19.1	
730317	DRIVE,1.0HP,266RPM,7/8SH,115/208-230V,60H,1P	58.5	26.5	
730318	DRIVE,1.5HP,266RPM,7/8SH,115/230V,60H,1P	80.0	36.3	
735330	DRIVE, .50HP,296/359RPM,7/8SH,190/380&208-230/460V,50&60H,3P	33.0	15.0	
735331	DRIVE, .75HP,296/359RPM,7/8SH,190/380&208-230/460V,50&60H,3P	33.6	15.2	
735332	DRIVE,1.0HP,296/359RPM,7/8SH,190/380&208-230/460V,50&60H,3P	43.0	19.5	
735333	DRIVE,1.5HP,296/359RPM,7/8SH,190/380&208-230/460V,50&60H,3P	50.0	37.2	
735342	DRIVE,1.0HP,365RPM,7/8SH,110/220V,50H,1P	46.0	20.9	
735343	DRIVE,1.5HP,365RPM,7/8SH,110/220V,50H,1P	80.0	36.3	
735360	DRIVE, .50HP,365/441RPM,7/8SH,115/230V,50/60H,1P	50.0	22.7	
735361	DRIVE, .75HP,365/441RPM,7/8SH,115/230V,50/60H,1P	53.0	24.0	
735362	DRIVE,1.0HP,441RPM,7/8SH,115/208-230V,60H,1P	46.0	20.9	
735363	DRIVE,1.5HP,441RPM,7/8SH,115/230V,60H,1P	80.0	36.3	
735380	DRIVE, .50HP,296/359RPM,7/8SH,115/230V,50/60H,1P	34.0	15.4	
735381	DRIVE, .75HP,296/359RPM,7/8SH,115/230V,50/60H,1P	41.9	19.0	
735382	DRIVE,1.0HP,359RPM,7/8SH,115/208-230V,60H,1P	43.0	19.5	
735383	DRIVE,1.5HP,359RPM,7/8SH,115/230V,60H,1P	51.8	23.5	
735510	DRIVE, .50HP,365/441RPM,7/8SH,190/380&208-230/460V,50&60H,3P	52.0	23.6	
735511	DRIVE, .75HP,365/441RPM,7/8SH,190/380&208-230/460V,50&60H,3P	35.0	15.9	
735512	DRIVE,1.0HP,365/441RPM,7/8SH,190/380&208-230/460V,50&60H,3P	45.0	20.4	
735513	DRIVE,1.5HP,365/441RPM,7/8SH,190/380&208-230/460V,50&60H,3P	50.4	22.8	
735515	DRIVE, .50HP,220/266RPM,7/8SH,190/380&208-230/460V,50&60H,3P	52.0	23.6	
735516	DRIVE, .75HP,220/266RPM,7/8SH,190/380&208-230/460V,50&60H,3P	55.0	24.9	
735517	DRIVE,1.0HP,220/266RPM,7/8SH,190/380&208-230/460V,50&60H,3P	60.5	27.4	
735518	DRIVE,1.5HP,220/266RPM,7/8SH,190/380&208-230/460V,50&60H,3P	82.0	37.2	
735520	DRIVE, .50HP,156/189RPM,7/8SH,190/380&208-230/460V,50&60H,3P	52.0	23.6	
735521	DRIVE, .75HP,156/189RPM,7/8SH,190/380&208-230/460V,50&60H,3P	55.0	24.9	
735522	DRIVE,1.0HP,156/189RPM,7/8SH,190/380&208-230/460V,50&60H,3P	60.5	27.4	
735523	DRIVE,1.5HP,156/189RPM,7/8SH,190/380&208-230/460V,50&60H,3P	82.0	37.2	

See page 04-24 for Direct Drive Table

PINION TOOL

CATALOG #	ITEM DESCRIPTION	SHIP WEIGHT		LIST PRICE
		LBS.	KG.	
740517	Pinion Spacer - Field Tool	0.5	0.2	

V-BELT DRIVE UNIT

713230	V-Belt Drive Unit (for use on STEEL Discharge Head Only) - Motor Pulley, Driven Pulley, and V-Belt - Motor NOT Included Requires Motor (Section 20) Requires Port & Driver Kit for 5/8" Shaft (page 04-17)	24.7	11.2	
--------	--	------	------	--

CONTROLS & SWITCHES

Hopper Switch Levels

CATALOG #	ITEM DESCRIPTION	SHIP WEIGHT		LIST PRICE
		LBS.	KG.	
460057	Hopper Level Control Switch - Proximity	5.0	2.3	
720097	Adjustable-Mechanical hopper level control 220V, 20amp, 1-3phase, 50-60hz	4.8	2.2	
451364	Hanger for Poly Hopper Switch	1.6	0.7	

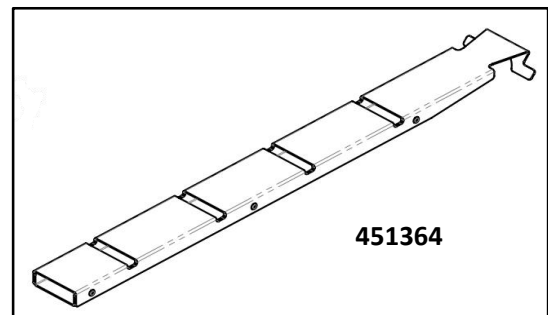
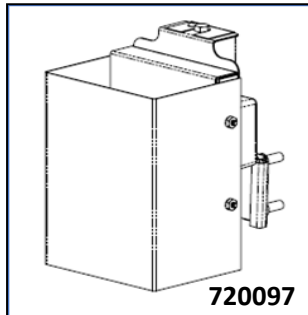
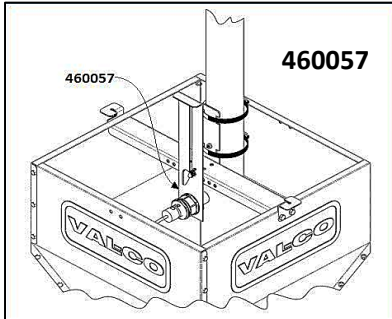

Discharge Head / Drop Tube Switch

730549	Proximity Sensor with Time Delay and Mount Kit - Short Delay - 90-265v, 3 sec. - 10 min. Delay	0.4	0.2	
730465	Proximity Sensor with Time Delay and Mount Kit - Long Delay - 90-265v, 3 sec. - 60 min. Delay	0.9	0.4	
735620	Downspout Feed Control Mechanical Switch FITS 3.5" I.D. DOWNSPOUT TUBE	7.7	3.5	

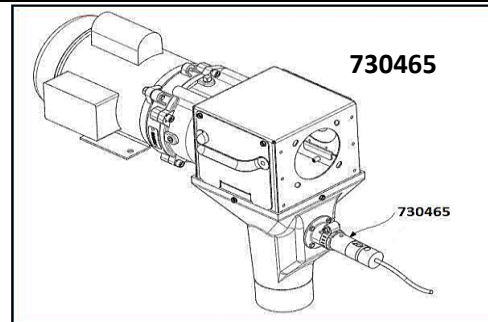
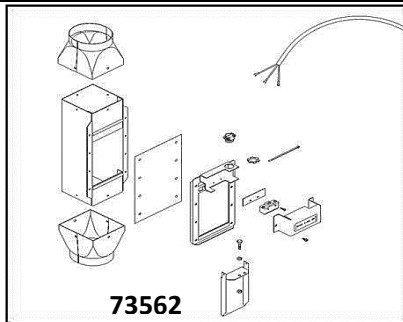

Boot Safety Switch

730965	Boot Safety Switch - Mechanical 110-220v, 20 amp, 1 phase, 50-60hz	1.1	0.5	
455800	Boot Safety Switch Proximity switch, 0-60 sec. delay, adj. sensitivity, 1P/220v/50-60	4.0	1.80	

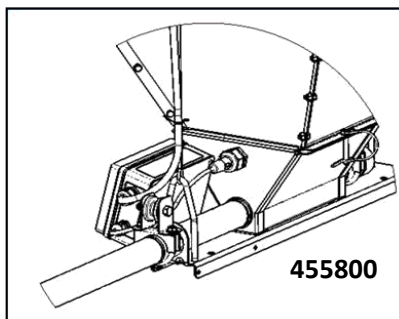
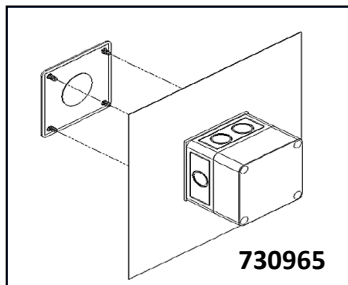

Time Clock / Timer

700025	24 Hour Time Clock - 230V	3.0	1.4	
700024	24 Hour Time Clock - 115V	3.0	1.4	

FLEXIBLE AUGER FEED DELIVERY SYSTEMS 45 DEGREE ENTRANCE SYSTEMS

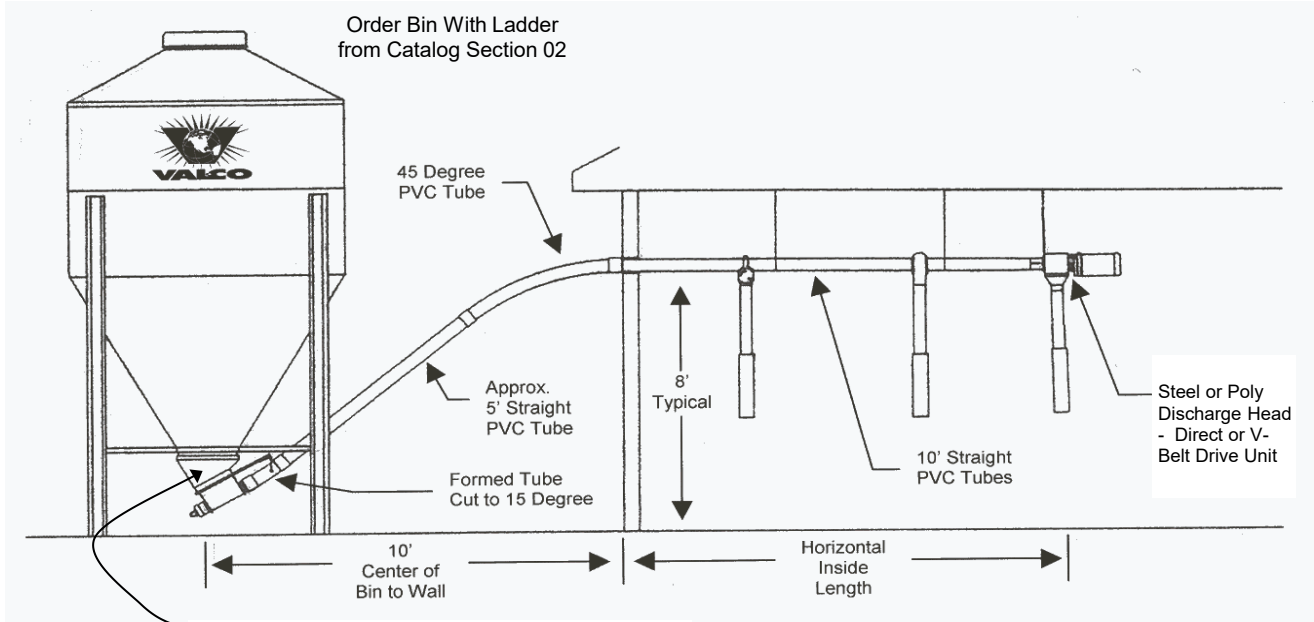

500475 or 500575
30 Degree Plastic Upper Boot Transition

For 45° Entrance System Pricing & Component Requirements:

MODEL 720 SYSTEMS - See pages 04-31

MODEL 725 SYSTEMS - See pages 04-35

MODEL 730 SYSTEMS - See page 04-39

MODEL 735 HV SYSTEMS - See page 04-43

MODEL 735 HM SYSTEMS - See page 04-47

FLEXIBLE AUGER FEED DELIVERY SYSTEMS 30 DEGREE ENTRANCE SYSTEMS

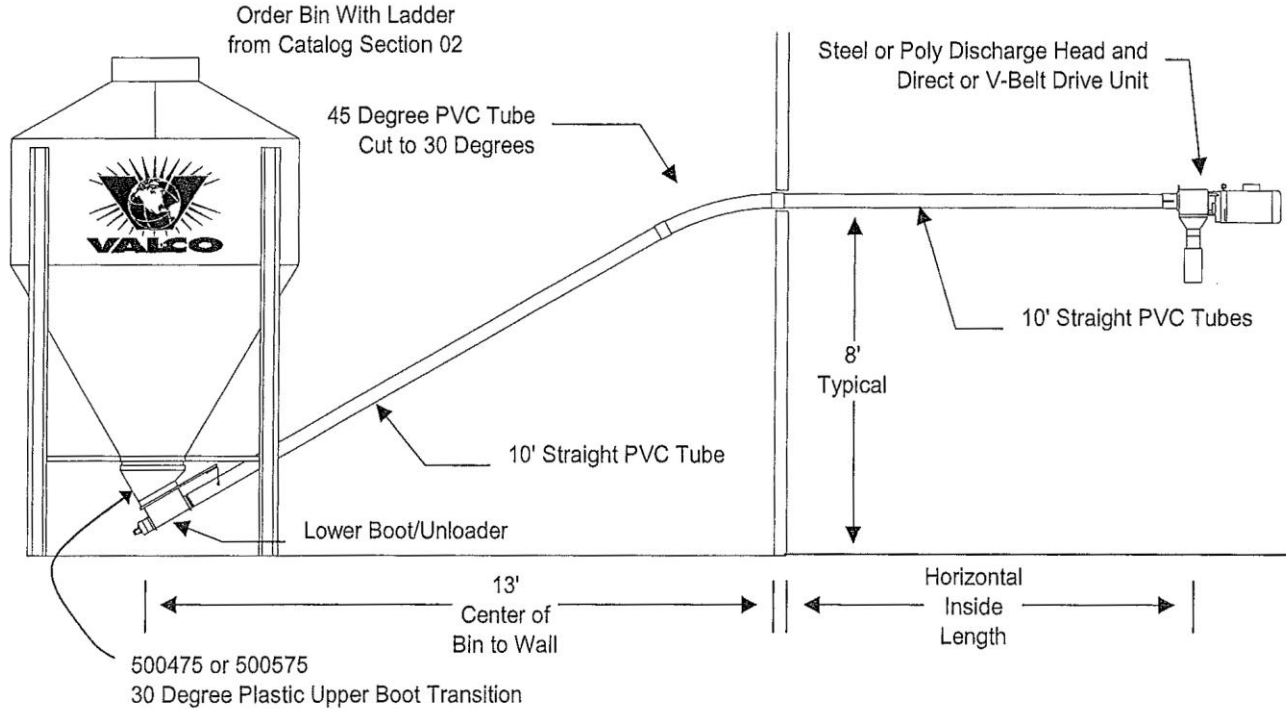

For 30° Entrance System Pricing & Component Requirements:

MODEL 720 SYSTEMS - See pages 04-32

MODEL 725 SYSTEMS - See pages 04-36

MODEL 730 SYSTEMS - See page 04-40

MODEL 735 HV SYSTEMS - See page 04-44

MODEL 735 HM SYSTEMS - See page 04-48

FLEXIBLE AUGER FEED DELIVERY SYSTEMS PASS-THRU SYSTEMS

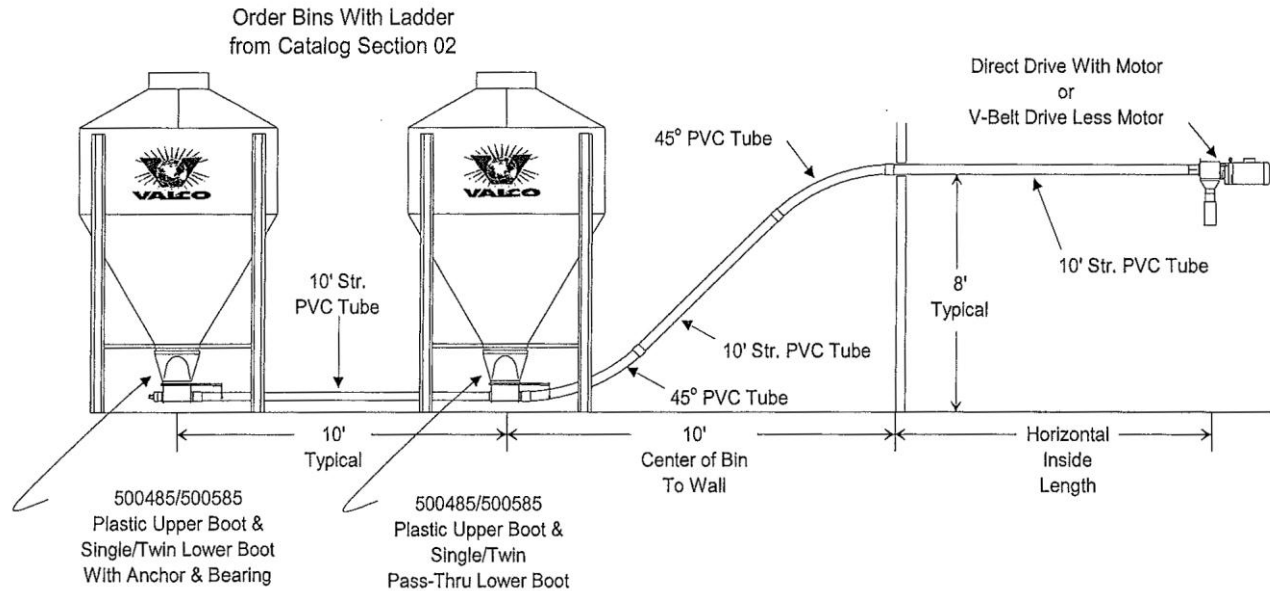

For Pass-Thru System Pricing & Component Requirements:

MODEL 720 SYSTEMS - See pages 04-33

MODEL 725 SYSTEMS - See pages 04-37

MODEL 730 SYSTEMS - See page 04-41

MODEL 735 HV SYSTEMS - See page 04-45

MODEL 735 HM SYSTEMS - See page 04-49

FLEXIBLE AUGER FEED DELIVERY SYSTEMS EXTENDED LENGTH SYSTEMS

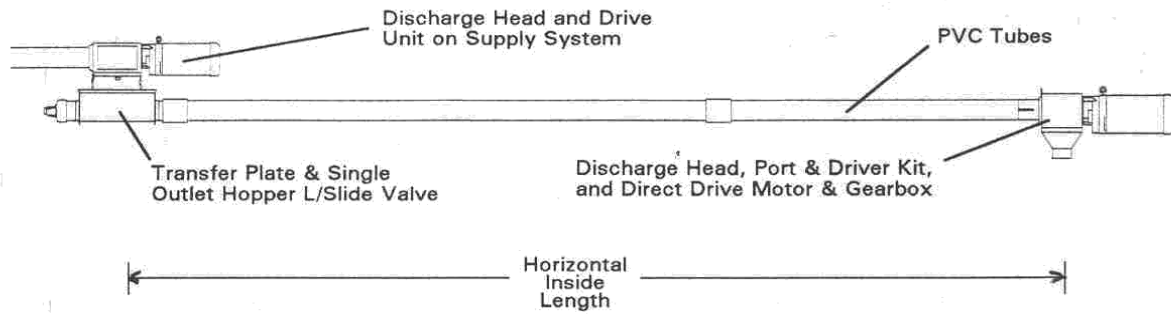

For Extended Length System Pricing & Component Requirements:

MODEL 720 SYSTEMS - See pages 04-34

MODEL 725 SYSTEMS - See pages 04-38

MODEL 730 SYSTEMS - See page 04-42

MODEL 735 HV SYSTEMS - See page 04-46

MODEL 735 HM SYSTEMS - See page 04-50

RECOMMENDATION: Select a drive unit with a faster output rpm for the extended system than for the supply (entrance or pass-thru) system.



MODEL 720 - 2.25" COMPONENTS - 45° ENTRANCE SYSTEM

REFER TO 45° ENTRANCE DRAWING ON PAGE 04-27

CATALOG NUMBER	COMPONENT DESCRIPTION	HORIZONTAL INSIDE LENGTH OF SYSTEM													
		FT	10	20	30	40	50	60	70	80	90	100	110	120	130
		M	3.1	6.1	9.2	12.2	15.3	18.3	21.4	24.4	27.5	30.5	33.6	36.6	39.7
ORDER THE INDICATED QTY	LINE COMPONENTS:														
	720498	45° Formed PVC Tube	2	2	2	2	2	2	2	2	2	2	2	2	2
	720434	10' Straight PVC Tube	2	3	4	5	6	7	8	9	10	11	12	13	14
	730415	PVC Cement - 1/2 Pint	1	1	1	1	1	1	1	1	2	2	2	2	2
	720440	1.52" OD Auger (feet)	30	40	50	60	70	80	90	100	110	120	130	140	150
SELECT ¹	Discharge Head	1	1	1	1	1	1	1	1	1	1	1	1	1	
DIRECT OR BELT DRIVE UNIT	DIRECT DRIVE UNIT:														
	SELECT ²	.50 HP Direct Drive	1	1	1	1	1	1	1	1	1	1	1	1	1
	SELECT ³	.75 HP Direct Drive	1	1	1	1	1	1	1	1	1	1	1	1	1
	V-BELT DRIVE UNIT:														
	713230	V-Belt Drive Unit	1	1	1	1	1	1	1	1	1	1	1	1	1
SELECT ³	Port & Driver Kit	1	1	1	1	1	1	1	1	1	1	1	1	1	
SELECT ⁴	.50 HP Direct Drive	1	1	1	1	1	1	1	1	1	1	1	1	1	
ORDER IF NEEDED	OPTIONAL SUSPENSION (CHOOSE HANGERS OR CHAIN):														
	VEN91504C	5/16" x 3.5" Screw Hook	3	5	8	10	13	15	18	20	23	25	28	30	33
	720220	Formed Hanger	3	5	8	10	13	15	18	20	23	25	28	30	33
	820099	#2 Hanger Chain (feet)	8	13	20	25	33	38	45	50	58	63	70	75	83

CATALOG NUMBER	COMPONENT DESCRIPTION	HORIZONTAL INSIDE LENGTH OF SYSTEM													
		FT	140	150	160	170	180	190	200	210	220	230	240	250	
		M	42.7	45.8	48.8	51.9	54.9	58	61	64.1	67.1	70.2	73.2	76.3	
ORDER THE INDICATED QTY	LINE COMPONENTS:														
	720498	45° Formed PVC Tube	2	2	2	2	2	2	2	2	2	2	2	2	2
	720434	10' Straight PVC Tube	15	16	17	18	19	20	21	22	23	24	25	26	
	730415	PVC Cement - 1/2 Pint	2	2	2	2	2	3	3	3	3	3	3	3	
	720440	1.52" OD Auger (feet)	160	170	180	190	200	210	220	230	240	250	260	270	
SELECT ¹	Discharge Head	1	1	1	1	1	1	1	1	1	1	1	1		
DIRECT OR BELT DRIVE UNIT	DIRECT DRIVE UNIT:														
	SELECT ²	.50 HP Direct Drive	1	1	1	1	1	1	1	1	1	1	1	1	
	SELECT ³	Port & Driver Kit	1	1	1	1	1	1	1	1	1	1	1	1	
	V-BELT DRIVE UNIT:														
	713230	V-Belt Drive Unit	1	1	1	1	1	1	1	1	1	1	1	1	
SELECT ³	Port & Driver Kit	1	1	1	1	1	1	1	1	1	1	1	1		
SELECT ⁴	.50 HP Direct Drive	1	1	1	1	1	1	1	1	1	1	1	1		
ORDER IF NEEDED	OPTIONAL SUSPENSION (CHOOSE HANGERS OR CHAIN):														
	VEN91504C	5/16" x 3.5" Screw Hook	35	38	40	43	45	48	50	53	55	58	60	63	
	720220	Formed Hanger	35	38	40	43	45	48	50	53	55	58	60	63	
	820099	#2 Hanger Chain (feet)	88	95	100	108	113	120	125	133	138	145	150	158	

¹ Select steel or poly discharge head from pages 04-18 and 04-20.

² Select motor & gearbox unit from pages 04-24 and 04-25.

³ Select correct port & driver kit from page 04-23.

⁴ Select farm duty motor from section 20.



MODEL 720 - 2.25" COMPONENTS - 30° ENTRANCE SYSTEM

REFER TO 30° ENTRANCE DRAWING ON PAGE 04-28

	CATALOG NUMBER	COMPONENT DESCRIPTION	HORIZONTAL INSIDE LENGTH OF SYSTEM													
			FT	10	20	30	40	50	60	70	80	90	100	110	120	130
			M	3.1	6.1	9.2	12.2	15.3	18.3	21.4	24.4	27.5	30.5	33.6	36.6	39.7
ORDER THE INDICATED QTY	LINE COMPONENTS:															
	720498	45° Formed PVC Tube	1	1	1	1	1	1	1	1	1	1	1	1	1	
	720434	10' Straight PVC Tube	2	3	4	5	6	7	8	9	10	11	12	13	14	
	730415	PVC Cement - 1/2 Pint	1	1	1	1	1	1	1	1	2	2	2	2	2	
	720440	1.52" OD Auger (feet)	30	40	50	60	70	80	90	100	110	120	130	140	150	
	SELECT ¹	Discharge Head	1	1	1	1	1	1	1	1	1	1	1	1	1	
DIRECT OR BELT DRIVE UNIT	DIRECT DRIVE UNIT:															
	SELECT ²	.50 HP Direct Drive	1	1	1	1	1	1	1	1	1	1	1	1	1	
	SELECT ³	.75 HP Direct Drive	1	1	1	1	1	1	1	1	1	1	1	1	1	
	V-BELT DRIVE UNIT:															
	713230	V-Belt Drive Unit	1	1	1	1	1	1	1	1	1	1	1	1	1	
	SELECT ³	Port & Driver Kit	1	1	1	1	1	1	1	1	1	1	1	1	1	
	SELECT ⁴	.50 HP Direct Drive	1	1	1	1	1	1	1	1	1	1	1	1	1	
ORDER IF NEEDED	OPTIONAL SUSPENSION (CHOOSE HANGERS OR CHAIN):															
	VEN91504C	5/16" x 3.5" Screw Hook	3	5	8	10	13	15	18	20	23	25	28	30	33	
	720220	Formed Hanger	3	5	8	10	13	15	18	20	23	25	28	30	33	
	820099	#2 Hanger Chain (feet)	8	13	20	25	33	38	45	50	58	63	70	75	83	

	CATALOG NUMBER	COMPONENT DESCRIPTION	HORIZONTAL INSIDE LENGTH OF SYSTEM												
			FT	140	150	160	170	180	190	200	210	220	230	240	250
			M	42.7	45.8	48.8	51.9	54.9	58	61	64.1	67.1	70.2	73.2	76.3
ORDER THE INDICATED QTY	LINE COMPONENTS:														
	720498	45° Formed PVC Tube	2	2	2	2	2	2	2	2	2	2	2	2	
	720434	10' Straight PVC Tube	15	16	17	18	19	20	21	22	23	24	25	26	
	730415	PVC Cement - 1/2 Pint	2	2	2	2	2	3	3	3	3	3	3	3	
	720440	1.52" OD Auger (feet)	160	170	180	190	200	210	220	230	240	250	260	270	
	SELECT ¹	Discharge Head	1	1	1	1	1	1	1	1	1	1	1	1	
DIRECT OR BELT DRIVE UNIT	DIRECT DRIVE UNIT:														
	SELECT ²	.50 HP Direct Drive	1	1	1	1	1	1	1	1	1	1	1	1	
	SELECT ³	Port & Driver Kit	1	1	1	1	1	1	1	1	1	1	1	1	
	V-BELT DRIVE UNIT:														
	713230	V-Belt Drive Unit	1	1	1	1	1	1	1	1	1	1	1	1	
	SELECT ³	Port & Driver Kit	1	1	1	1	1	1	1	1	1	1	1	1	
	SELECT ⁴	.50 HP Direct Drive	1	1	1	1	1	1	1	1	1	1	1	1	
ORDER IF NEEDED	OPTIONAL SUSPENSION (CHOOSE HANGERS OR CHAIN):														
	VEN91504C	5/16" x 3.5" Screw Hook	35	38	40	43	45	48	50	53	55	58	60	63	
	720220	Formed Hanger	35	38	40	43	45	48	50	53	55	58	60	63	
	820099	#2 Hanger Chain (feet)	88	95	100	108	113	120	125	133	138	145	150	158	

¹ Select steel or poly discharge head from pages 04-18 and 04-20.

² Select motor & gearbox unit from pages 04-24 and 04-25.

³ Select correct port & driver kit from page 04-23.

⁴ Select farm duty motor from section 20.



MODEL 720 - 2.25" COMPONENTS - PASS-THRU SYSTEM

REFER TO PASS-THRU DRAWING ON PAGE 04-29

CATALOG NUMBER	COMPONENT DESCRIPTION	HORIZONTAL INSIDE LENGTH OF SYSTEM													
		FT	10	20	30	40	50	60	70	80	90	100	110	120	130
		M	3.1	6.1	9.2	12.2	15.3	18.3	21.4	24.4	27.5	30.5	33.6	36.6	39.7
ORDER THE INDICATED QTY	LINE COMPONENTS:														
	720498	45° Formed PVC Tube	0	0	0	0	0	0	0	0	0	0	0	0	0
	720434	10' Straight PVC Tube	3	4	5	6	7	8	9	10	11	12	13	14	15
	730415	PVC Cement - 1/2 Pint	1	1	1	1	1	1	1	1	2	2	2	2	2
	720440	1.52" OD Auger (feet)	50	60	70	80	90	100	110	120	130	140	150	160	170
SELECT ¹	Discharge Head	1	1	1	1	1	1	1	1	1	1	1	1	1	
DIRECT OR BELT DRIVE UNIT	DIRECT DRIVE UNIT:														
	SELECT ²	.50 HP Direct Drive	1	1	1	1	1	1	1	1	1	1	1	1	1
	SELECT ³	.75 HP Direct Drive	1	1	1	1	1	1	1	1	1	1	1	1	1
	V-BELT DRIVE UNIT:														
	713230	V-Belt Drive Unit	1	1	1	1	1	1	1	1	1	1	1	1	1
	SELECT ³	Port & Driver Kit	1	1	1	1	1	1	1	1	1	1	1	1	1
SELECT ⁴	.50 HP Direct Drive	1	1	1	1	1	1	1	1	1	1	1	1	1	
ORDER IF NEEDED	OPTIONAL SUSPENSION (CHOOSE HANGERS OR CHAIN):														
	VEN91504C	5/16" x 3.5" Screw Hook	3	5	8	10	13	15	18	20	23	25	28	30	33
	720220	Formed Hanger	3	5	8	10	13	15	18	20	23	25	28	30	33
	820099	#2 Hanger Chain (feet)	8	13	20	25	33	38	45	50	58	63	70	75	83

CATALOG NUMBER	COMPONENT DESCRIPTION	HORIZONTAL INSIDE LENGTH OF SYSTEM							
		FT	140	150	160	170	180	190	200
		M	42.7	45.8	48.8	51.9	54.9	58	61
ORDER THE INDICATED QTY	LINE COMPONENTS:								
	720498	45° Formed PVC Tube	0	0	0	0	0	0	0
	720434	10' Straight PVC Tube	16	17	18	19	20	21	22
	730415	PVC Cement - 1/2 Pint	2	2	2	2	2	3	3
	720440	1.52" OD Auger (feet)	180	190	200	210	220	230	240
SELECT ¹	Discharge Head	1	1	1	1	1	1	1	
DIRECT OR BELT DRIVE UNIT	DIRECT DRIVE UNIT:								
	SELECT ²	.50 HP Direct Drive	1	1	1	1	1	1	1
	SELECT ³	Port & Driver Kit	1	1	1	1	1	1	1
	V-BELT DRIVE UNIT:								
	713230	V-Belt Drive Unit	1	1	1	1	1	1	1
	SELECT ³	Port & Driver Kit	1	1	1	1	1	1	1
SELECT ⁴	.50 HP Direct Drive	1	1	1	1	1	1	1	
ORDER IF NEEDED	OPTIONAL SUSPENSION (CHOOSE HANGERS OR CHAIN):								
	VEN91504C	5/16" x 3.5" Screw Hook	35	38	40	43	45	48	50
	720220	Formed Hanger	35	38	40	43	45	48	50
	820099	#2 Hanger Chain (feet)	88	95	100	108	113	120	125

¹ Select steel or poly discharge head from pages 04-18 and 04-20.

² Select motor & gearbox unit from pages 04-24 and 04-25.

³ Select correct port & driver kit from page 04-23.

⁴ Select farm duty motor from section 20.



MODEL 720 - 2.25" COMPONENTS - EXTENDED LENGTH SYSTEM

REFER TO EXTENDED LENGTH DRAWING ON PAGE 04-30

CATALOG NUMBER	COMPONENT DESCRIPTION	HORIZONTAL INSIDE LENGTH OF SYSTEM															
		FT	10	20	30	40	50	60	70	80	90	100	110	120	130	140	150
		M	3.1	6.1	9.2	12	15	18.3	21	24	28	31	34	37	40	43	46
ORDER THE INDICATED QTY	LINE COMPONENTS:																
	720964	Lower Boot Less Slide Valve	1	1	1	1	1	1	1	1	1	1	1	1	1	1	1
	SELECT ⁴	Adapter Plate	1	1	1	1	1	1	1	1	1	1	1	1	1	1	1
	720434	10' Straight PVC Tube	1	2	3	4	5	6	7	8	9	10	11	12	13	14	15
	730415	PVC Cement - 1/2 Pint	1	1	1	1	1	1	1	1	1	2	2	2	2	2	2
	720440	1.52" OD Auger (feet)	20	30	40	50	60	70	80	90	100	110	120	130	140	150	160
SELECT ¹	Discharge Head	1	1	1	1	1	1	1	1	1	1	1	1	1	1	1	
DRIVE UNIT	DIRECT DRIVE UNIT:																
	SELECT ²	.75 HP Direct Drive	1	1	1	1	1	1	1	1	1	1	1	1	1	1	1
	SELECT ³	Port & Driver Kit	1	1	1	1	1	1	1	1	1	1	1	1	1	1	1
ORDER IF NEEDED	OPTIONAL SUSPENSION (CHOOSE HANGERS OR CHAIN):																
	VEN91504C	5/16" x 3.5" Screw Hook	3	5	8	10	13	15	18	20	23	25	28	30	33	35	38
	720220	Formed Hanger	3	5	8	10	13	15	18	20	23	25	28	30	33	35	38
	820099	#2 Hanger Chain (feet)	8	13	20	25	33	38	45	50	58	63	70	75	83	88	95

CATALOG NUMBER	COMPONENT DESCRIPTION	HORIZONTAL INSIDE LENGTH OF SYSTEM															
		FT	160	170	180	190	200	210	220	230	240	250	260	270	280	290	
		M	49	52	55	58	61	64.1	67	70	73	76	79	82	85	88	
ORDER THE INDICATED QTY	LINE COMPONENTS:																
	720964	Lower Boot Less Slide Valve	1	1	1	1	1	1	1	1	1	1	1	1	1	1	1
	SELECT ⁴	Adapter Plate	1	1	1	1	1	1	1	1	1	1	1	1	1	1	1
	720434	10' Straight PVC Tube	16	17	18	19	20	21	22	23	24	25	26	27	28	29	
	730415	PVC Cement - 1/2 Pint	2	2	2	2	3	3	3	3	3	3	3	3	3	3	3
	720440	1.52" OD Auger (feet)	170	180	190	200	210	220	230	240	250	260	270	280	290	300	
SELECT ¹	Discharge Head	1	1	1	1	1	1	1	1	1	1	1	1	1	1	1	
DRIVE UNIT	DIRECT DRIVE UNIT:																
	SELECT ²	.50 HP Direct Drive	1	1	1	1	1	1	1	1	1	1	1	1	1	1	1
	SELECT ³	Port & Driver Kit	1	1	1	1	1	1	1	1	1	1	1	1	1	1	1
ORDER IF NEEDED	OPTIONAL SUSPENSION (CHOOSE HANGERS OR CHAIN):																
	VEN91504C	5/16" x 3.5" Screw Hook	40	43	45	48	50	53	55	58	60	63	65	68	70	73	
	720220	Formed Hanger	40	43	45	48	50	53	55	58	60	63	65	68	70	73	
	820099	#2 Hanger Chain (feet)	100	108	113	120	125	133	138	145	150	158	163	170	175	183	

¹ Select steel or poly discharge head from pages 04-18 and 04-20.

² Select motor & gearbox unit from pages 04-24 and 04-25 (See recommendation on selecting drive RPMs on page 04-30).

³ Select correct port & driver kit from page 04-23.

⁴ Select adapter plate (for steel or poly discharge head) from page 04-07.

MODEL 725 - 3" COMPONENTS - 45° ENTRANCE SYSTEM

REFER TO 45° ENTRANCE DRAWING PAGE 04-27

ORDER THE INDICATED QTY	CATALOG NUMBER	COMPONENT DESCRIPTION	HORIZONTAL INSIDE LENGTH OF SYSTEM										
			FT	10	20	30	40	50	60	70	80	90	100
			M	3.1	6.1	9.2	12.2	15.3	18.3	21.4	24.4	27.5	30.5
ORDER THE INDICATED QTY	LINE COMPONENTS:												
	730499	45° Formed PVC Tube	2	2	2	2	2	2	2	2	2	2	
	730434	10' Straight PVC Tube	2	3	4	5	6	7	8	9	10	11	
	730415	PVC Cement - 1/2 Pint	1	1	1	1	1	1	1	1	2	2	
	725440	2.25" OD Auger (feet)	30	40	50	60	70	80	90	100	110	120	
	SELECT ¹	Discharge Head	1	1	1	1	1	1	1	1	1	1	
DIRECT OR BELT DRIVE UNIT	DIRECT DRIVE UNIT:												
	SELECT ²	.50 HP Direct Drive	1	1	1	1	1	1	1	1	0	0	
	SELECT ²	.75 HP Direct Drive	0	0	0	0	0	0	0	0	1	1	
	SELECT ²	1.0 HP Direct Drive	0	0	0	0	0	0	0	0	0	0	
	SELECT ³	Port & Driver Kit	1	1	1	1	1	1	1	1	1	1	
	V-BELT DRIVE UNIT:												
	713230	V-Belt Drive Unit	1	1	1	1	1	1	1	1	1	1	
	SELECT ³	Port & Driver Kit	1	1	1	1	1	1	1	1	1	1	
	SELECT ⁴	Farm Duty Motor (see HP above)	1	1	1	1	1	1	1	1	1	1	
ORDER IF NEEDED	OPTIONAL SUSPENSION (CHOOSE HANGERS OR CHAIN):												
	VEN91504C	5/16" x 3.5" Screw Hook	3	5	8	10	13	15	18	20	23	25	
	713220 or 713223	Formed Hanger Galv (713220) or SS (713223)	3	5	8	10	13	15	18	20	23	25	
	820099	#2 Hanger Chain (feet)	8	13	20	25	33	38	45	50	58	63	

ORDER THE INDICATED QTY	CATALOG NUMBER	COMPONENT DESCRIPTION	HORIZONTAL INSIDE LENGTH OF SYSTEM										
			FT	110	120	130	140	150	160	170	180	190	200
			M	33.6	36.6	39.7	42.7	45.8	48.8	51.9	54.9	58	61
ORDER THE INDICATED QTY	LINE COMPONENTS:												
	730499	45° Formed PVC Tube	2	2	2	2	2	2	2	2	2	2	
	730434	10' Straight PVC Tube	12	13	14	15	16	17	18	19	20	21	
	730415	PVC Cement - 1/2 Pint	2	2	2	2	2	2	2	2	3	3	
	725440	2.25" OD Auger (feet)	130	140	150	160	170	180	190	200	210	220	
	SELECT ¹	Discharge Head	1	1	1	1	1	1	1	1	1	1	
DIRECT OR BELT DRIVE UNIT	DIRECT DRIVE UNIT:												
	SELECT ²	.50 HP Direct Drive	0	0	0	0	0	0	0	0	0	0	
	SELECT ²	.75 HP Direct Drive	1	1	1	1	1	0	0	0	0	0	
	SELECT ²	1.0 HP Direct Drive	0	0	0	0	0	1	1	1	1	1	
	SELECT ³	Port & Driver Kit	1	1	1	1	1	1	1	1	1	1	
	V-BELT DRIVE UNIT:												
	713230	V-Belt Drive Unit	1	1	1	1	1	1	1	1	1	1	
	SELECT ³	Port & Driver Kit	1	1	1	1	1	1	1	1	1	1	
	SELECT ⁴	Farm Duty Motor (see HP above)	1	1	1	1	1	1	1	1	1	1	
ORDER IF NEEDED	OPTIONAL SUSPENSION (CHOOSE HANGERS OR CHAIN):												
	VEN91504C	5/16" x 3.5" Screw Hook	28	30	33	35	38	40	43	45	48	50	
	713220 or 713223	Formed Hanger Galv (713220) or SS (713223)	28	30	33	35	38	40	43	45	48	50	
	820099	#2 Hanger Chain (feet)	70	75	83	88	95	100	108	113	120	125	

¹ Select steel or poly discharge head from pages 04-18 and 04-20.

² Select motor & gearbox unit from pages 04-24 and 04-25.

³ Select correct port & driver kit from page 04-23.

⁴ Select farm duty motor from section 20.



MODEL 725 - 3" COMPONENTS - 30° ENTRANCE SYSTEM

REFER TO 30° ENTRANCE DRAWING PAGE 04-28

ORDER THE INDICATED QTY	CATALOG NUMBER	COMPONENT DESCRIPTION	HORIZONTAL INSIDE LENGTH OF SYSTEM										
			FT	10	20	30	40	50	60	70	80	90	100
			M	3.1	6.1	9.2	12.2	15.3	18.3	21.4	24.4	27.5	30.5
ORDER THE INDICATED QTY	LINE COMPONENTS:												
	730499	45° Formed PVC Tube	1	1	1	1	1	1	1	1	1	1	
	730434	10' Straight PVC Tube	2	3	4	5	6	7	8	9	10	11	
	730415	PVC Cement - 1/2 Pint	1	1	1	1	1	1	1	1	2	2	
	725440	2.25" OD Auger (feet)	30	40	50	60	70	80	90	100	110	120	
	SELECT ¹	Discharge Head	1	1	1	1	1	1	1	1	1	1	
DIRECT OR BELT DRIVE UNIT	DIRECT DRIVE UNIT:												
	SELECT ²	.50 HP Direct Drive	1	1	1	1	1	1	1	1	0	0	
	SELECT ²	.75 HP Direct Drive	0	0	0	0	0	0	0	0	1	1	
	SELECT ²	1.0 HP Direct Drive	0	0	0	0	0	0	0	0	0	0	
	SELECT ³	Port & Driver Kit	1	1	1	1	1	1	1	1	1	1	
	V-BELT DRIVE UNIT:												
	713230	V-Belt Drive Unit	1	1	1	1	1	1	1	1	1	1	
	SELECT ³	Port & Driver Kit	1	1	1	1	1	1	1	1	1	1	
SELECT ⁴	Farm Duty Motor (see HP above)	1	1	1	1	1	1	1	1	1	1		
ORDER IF NEEDED	OPTIONAL SUSPENSION (CHOOSE HANGERS OR CHAIN):												
	VEN91504C	5/16" x 3.5" Screw Hook	3	5	8	10	13	15	18	20	23	25	
	713220 or 713223	Formed Hanger Galv (713220) or SS (713223)	3	5	8	10	13	15	18	20	23	25	
	820099	#2 Hanger Chain (feet)	8	13	20	25	33	38	45	50	58	63	

ORDER THE INDICATED QTY	CATALOG NUMBER	COMPONENT DESCRIPTION	HORIZONTAL INSIDE LENGTH OF SYSTEM										
			FT	110	120	130	140	150	160	170	180	190	200
			M	33.6	36.6	39.7	42.7	45.8	48.8	51.9	54.9	58	61
ORDER THE INDICATED QTY	LINE COMPONENTS:												
	730499	45° Formed PVC Tube	1	1	1	1	1	1	1	1	1	1	
	730434	10' Straight PVC Tube	12	13	14	15	16	17	18	19	20	21	
	730415	PVC Cement - 1/2 Pint	2	2	2	2	2	2	2	2	3	3	
	725440	2.25" OD Auger (feet)	130	140	150	160	170	180	190	200	210	220	
	SELECT ¹	Discharge Head	1	1	1	1	1	1	1	1	1	1	
DIRECT OR BELT DRIVE UNIT	DIRECT DRIVE UNIT:												
	SELECT ²	.50 HP Direct Drive	0	0	0	0	0	0	0	0	0	0	
	SELECT ²	.75 HP Direct Drive	1	1	1	1	1	0	0	0	0	0	
	SELECT ²	1.0 HP Direct Drive	0	0	0	0	0	1	1	1	1	1	
	SELECT ³	Port & Driver Kit	1	1	1	1	1	1	1	1	1	1	
	V-BELT DRIVE UNIT:												
	713230	V-Belt Drive Unit	1	1	1	1	1	1	1	1	1	1	
	SELECT ³	Port & Driver Kit	1	1	1	1	1	1	1	1	1	1	
SELECT ⁴	Farm Duty Motor (see HP above)	1	1	1	1	1	1	1	1	1	1		
ORDER IF NEEDED	OPTIONAL SUSPENSION (CHOOSE HANGERS OR CHAIN):												
	VEN91504C	5/16" x 3.5" Screw Hook	28	30	33	35	38	40	43	45	48	50	
	713220 or 713223	Formed Hanger Galv (713220) or SS (713223)	28	30	33	35	38	40	43	45	48	50	
	820099	#2 Hanger Chain (feet)	70	75	83	88	95	100	108	113	120	125	

¹ Select steel or poly discharge head from pages 04-18 and 04-20.

² Select motor & gearbox unit from pages 04-24 and 04-25.

³ Select correct port & driver kit from page 04-23

⁴ Select farm duty motor from section 20



MODEL 725 - 3" COMPONENTS - PASS-THRU SYSTEM

REFER TO PASS-THRU SYSTEM DRAWING PAGE 04-29

	CATALOG NUMBER	COMPONENT DESCRIPTION	HORIZONTAL INSIDE LENGTH OF SYSTEM										
			FT	10	20	30	40	50	60	70	80	90	100
			M	3.1	6.1	9.2	12.2	15.3	18.3	21.4	24.4	27.5	30.5
ORDER THE INDICATED QTY	LINE COMPONENTS:												
	730499	45° Formed PVC Tube	2	2	2	2	2	2	2	2	2	2	
	730434	10' Straight PVC Tube	3	4	5	6	7	8	9	10	11	12	
	730415	PVC Cement - 1/2 Pint	1	1	1	1	1	1	1	2	2	2	
	725440	2.25" OD Auger (feet)	50	60	70	80	90	100	110	120	130	140	
	SELECT ¹	Discharge Head	1	1	1	1	1	1	1	1	1	1	
DIRECT OR BELT DRIVE UNIT	DIRECT DRIVE UNIT:												
	SELECT ²	.50 HP Direct Drive	1	1	1	0	0	0	0	0	0	0	
	SELECT ²	.75 HP Direct Drive	0	0	0	1	1	1	1	1	1	0	
	SELECT ²	1.0 HP Direct Drive	0	0	0	0	0	0	0	0	0	1	
	SELECT ³	Port & Driver Kit	1	1	1	1	1	1	1	1	1	1	
	V-BELT DRIVE UNIT:												
	713230	V-Belt Drive Unit	1	1	1	1	1	1	1	1	1	1	
SELECT ³	Port & Driver Kit	1	1	1	1	1	1	1	1	1	1		
SELECT ⁴	Farm Duty Motor (see HP above)	1	1	1	1	1	1	1	1	1	1		
ORDER IF NEEDED	OPTIONAL SUSPENSION (CHOOSE HANGERS OR CHAIN):												
	VEN91504C	5/16" x 3.5" Screw Hook	3	5	8	10	13	15	18	20	23	25	
	713220 or 713223	Formed Hanger Galv (713220) or SS (713223)	3	5	8	10	13	15	18	20	23	25	
	820099	#2 Hanger Chain (feet)	8	13	20	25	33	38	45	50	58	63	

	CATALOG NUMBER	COMPONENT DESCRIPTION	HORIZONTAL INSIDE LENGTH OF SYSTEM					
			FT	110	120	130	140	150
			M	33.6	36.6	39.7	42.7	45.8
ORDER THE INDICATED QTY	LINE COMPONENTS:							
	730499	45° Formed PVC Tube	2	2	2	2	2	
	730434	10' Straight PVC Tube	13	14	15	16	17	
	730415	PVC Cement - 1/2 Pint	2	2	2	2	2	
	725440	2.25" OD Auger (feet)	150	160	170	180	190	
	SELECT ¹	Discharge Head	1	1	1	1	1	
DIRECT OR BELT DRIVE UNIT	DIRECT DRIVE UNIT:							
	SELECT ²	.50 HP Direct Drive	0	0	0	0	0	
	SELECT ²	.75 HP Direct Drive	0	0	0	0	0	
	SELECT ²	1.0 HP Direct Drive	1	1	1	1	0	
	SELECT ³	Port & Driver Kit	1	1	1	1	1	
	V-BELT DRIVE UNIT:							
	713230	V-Belt Drive Unit	1	1	1	1	1	
SELECT ³	Port & Driver Kit	1	1	1	1	1		
SELECT ⁴	Farm Duty Motor (see HP above)	1	1	1	1	1		
ORDER IF NEEDED	OPTIONAL SUSPENSION (CHOOSE HANGERS OR CHAIN):							
	VEN91504C	5/16" x 3.5" Screw Hook	28	30	33	35	38	
	713220 or 713223	Formed Hanger Galv (713220) or SS (713223)	28	30	33	35	38	
	820099	#2 Hanger Chain (feet)	70	75	83	88	95	

¹ Select steel or poly discharge head from pages 04-18 and 04-20.

² Select motor & gearbox unit from pages 04-24 and 04-25.

³ Select correct port & driver kit from page 04-23.

⁴ Select farm duty motor from section 20.



MODEL 725 - 3" COMPONENTS - EXTENDED LENGTH SYSTEM

REFER TO PASS-THRU SYSTEM DRAWING PAGE 04-29

	CATALOG NUMBER	COMPONENT DESCRIPTION	HORIZONTAL INSIDE LENGTH OF SYSTEM													
			FT	10	20	30	40	50	60	70	80	90	100	110	120	130
			M	3.1	6.1	9.2	12.2	15.3	18.3	21.4	24.4	27.5	30.5	33.6	36.6	39.7
ORDER THE INDICATED QTY	LINE COMPONENTS:															
	730912	Lower Boot Less Slide Valve	1	1	1	1	1	1	1	1	1	1	1	1	1	
	SELECT ⁴	Adapter Plate	1	1	1	1	1	1	1	1	1	1	1	1	1	
	730434	10' Straight PVC Tube	1	2	3	4	5	6	7	8	9	10	11	12	13	
	730415	PVC Cement - 1/2 Pint	1	1	1	1	1	1	1	1	1	2	2	2	2	
	725440	2.25" OD Auger (feet)	20	30	40	50	60	70	80	90	100	110	120	130	140	
ORDER THE DRIVE UNIT	SELECT ¹	Discharge Head	1	1	1	1	1	1	1	1	1	1	1	1		
ORDER IF NEEDED	DIRECT DRIVE UNIT:															
	SELECT ²	.50 HP Direct Drive	1	1	1	1	1	1	1	1	1	1	1	0	0	
	SELECT ²	.75 HP Direct Drive	0	0	0	0	0	0	0	0	0	0	0	1	1	
	SELECT ²	1.0 HP Direct Drive	0	0	0	0	0	0	0	0	0	0	0	0	0	
	SELECT ³	Port & Driver Kit	1	1	1	1	1	1	1	1	1	1	1	1	1	
ORDER IF NEEDED	OPTIONAL SUSPENSION (CHOOSE HANGERS OR CHAIN):															
	VEN91504C	5/16" x 3.5" Screw Hook	3	5	8	10	13	15	18	20	23	25	28	30	33	
	713220 or 713223	Formed Hanger Galv (713220) or SS (713223)	3	5	8	10	13	15	18	20	23	25	28	30	33	
	820099	#2 Hanger Chain (feet)	8	13	20	25	33	38	45	50	58	63	70	75	83	

	CATALOG NUMBER	COMPONENT DESCRIPTION	HORIZONTAL INSIDE LENGTH OF SYSTEM											
			FT	140	150	160	170	180	190	200	210	220	230	240
			M	42.7	45.8	48.8	51.9	54.9	58	61	64.1	67.1	70.2	73.2
ORDER THE INDICATED QTY	LINE COMPONENTS:													
	730912	Lower Boot Less Slide Valve	1	1	1	1	1	1	1	1	1	1	1	
	SELECT ⁴	Adapter Plate	1	1	1	1	1	1	1	1	1	1	1	
	730434	10' Straight PVC Tube	14	15	16	17	18	19	20	21	22	23	24	
	730415	PVC Cement - 1/2 Pint	2	2	2	2	2	2	3	3	3	3	3	
	725440	2.25" OD Auger (feet)	150	160	170	180	190	200	210	220	230	240	250	
ORDER THE DRIVE UNIT	SELECT ¹	Discharge Head	1	1	1	1	1	1	1	1	1	1	1	
ORDER IF NEEDED	DIRECT DRIVE UNIT:													
	SELECT ²	.50 HP Direct Drive	0	0	0	0	0	0	0	0	0	0	0	
	SELECT ²	.75 HP Direct Drive	1	1	1	1	1	0	0	0	0	0	0	
	SELECT ²	1.0 HP Direct Drive	0	0	0	0	0	1	1	1	1	1	1	
ORDER IF NEEDED	SELECT ³	Port & Driver Kit	1	1	1	1	1	1	1	1	1	1	1	
ORDER IF NEEDED	OPTIONAL SUSPENSION (CHOOSE HANGERS OR CHAIN):													
	VEN91504C	5/16" x 3.5" Screw Hook	35	38	40	43	45	48	50	53	55	58	60	
	713220 or 713223	Formed Hanger Galv (713220) or SS (713223)	35	38	40	43	45	48	50	53	55	58	60	
	820099	#2 Hanger Chain (feet)	88	95	100	108	113	120	125	133	138	145	150	

¹ Select steel or poly discharge head from pages 04-18 and 04-20.

² Select motor & gearbox unit from pages 04-24 and 04-25 (See recommendation on selecting drive RPMs on page 04-30).

³ Select correct port & driver kit from page 04-23.

⁴ Select adapter plate (for steel or poly discharge head) from page 04-07.

MODEL 730 - 3" COMPONENTS - 45° ENTRANCE SYSTEM

REFER TO 45° ENTRANCE DRAWING PAGE 04-27

CATALOG NUMBER	COMPONENT DESCRIPTION	HORIZONTAL INSIDE LENGTH OF SYSTEM										
		FT	10	20	30	40	50	60	70	80	90	100
		M	3.1	6.1	9.2	12.2	15.3	18.3	21.4	24.4	27.5	30.5
ORDER THE INDICATED QTY	LINE COMPONENTS:											
	730499	45° Formed PVC Tube	2	2	2	2	2	2	2	2	2	2
	730434	10' Straight PVC Tube	2	3	4	5	6	7	8	9	10	11
	730415	PVC Cement - 1/2 Pint	1	1	1	1	1	1	1	1	2	2
	730440	2.38" OD Auger (feet)	30	40	50	60	70	80	90	100	110	120
SELECT ¹	Discharge Head	1	1	1	1	1	1	1	1	1	1	
DIRECT OR BELT DRIVE UNIT	DIRECT DRIVE UNIT:											
	SELECT ²	.50 HP Direct Drive	1	1	1	1	1	1	1	1	0	0
	SELECT ²	.75 HP Direct Drive	0	0	0	0	0	0	0	0	1	1
	SELECT ²	1.0 HP Direct Drive	0	0	0	0	0	0	0	0	0	0
	SELECT ³	Port & Driver Kit	1	1	1	1	1	1	1	1	1	1
	V-BELT DRIVE UNIT:											
	713230	V-Belt Drive Unit	1	1	1	1	1	1	1	1	1	1
	SELECT ³	Port & Driver Kit	1	1	1	1	1	1	1	1	1	1
SELECT ⁴	Farm Duty Motor (see HP above)	1	1	1	1	1	1	1	1	1	1	
ORDER IF NEEDED	OPTIONAL SUSPENSION (CHOOSE HANGERS OR CHAIN):											
	VEN91504C	5/16" x 3.5" Screw Hook	3	5	8	10	13	15	18	20	23	25
	713220 or 713223	Formed Hanger Galv (713220) or SS (713223)	3	5	8	10	13	15	18	20	23	25
	820099	#2 Hanger Chain (feet)	8	13	20	25	33	38	45	50	58	63

CATALOG NUMBER	COMPONENT DESCRIPTION	HORIZONTAL INSIDE LENGTH OF SYSTEM										
		FT	110	120	130	140	150	160	170	180	190	200
		M	33.6	36.6	39.7	42.7	45.8	48.8	51.9	54.9	58	61
ORDER THE INDICATED QTY	LINE COMPONENTS:											
	730499	45° Formed PVC Tube	2	2	2	2	2	2	2	2	2	2
	730434	10' Straight PVC Tube	12	13	14	15	16	17	18	19	20	21
	730415	PVC Cement - 1/2 Pint	2	2	2	2	2	2	2	2	3	3
	730440	2.38" OD Auger (feet)	130	140	150	160	170	180	190	200	210	220
SELECT ¹	Discharge Head	1	1	1	1	1	1	1	1	1	1	
DIRECT OR BELT DRIVE UNIT	DIRECT DRIVE UNIT:											
	SELECT ²	.50 HP Direct Drive	0	0	0	0	0	0	0	0	0	0
	SELECT ²	.75 HP Direct Drive	1	1	1	1	1	0	0	0	0	0
	SELECT ²	1.0 HP Direct Drive	0	0	0	0	0	1	1	1	1	1
	SELECT ³	Port & Driver Kit	1	1	1	1	1	1	1	1	1	1
	V-BELT DRIVE UNIT:											
	713230	V-Belt Drive Unit	1	1	1	1	1	1	1	1	1	1
	SELECT ³	Port & Driver Kit	1	1	1	1	1	1	1	1	1	1
SELECT ⁴	Farm Duty Motor (see HP above)	1	1	1	1	1	1	1	1	1	1	
ORDER IF NEEDED	OPTIONAL SUSPENSION (CHOOSE HANGERS OR CHAIN):											
	VEN91504C	5/16" x 3.5" Screw Hook	28	30	33	35	38	40	43	45	48	50
	713220 or 713223	Formed Hanger Galv (713220) or SS (713223)	28	30	33	35	38	40	43	45	48	50
	820099	#2 Hanger Chain (feet)	70	75	83	88	95	100	108	113	120	125

¹ Select steel or poly discharge head from pages 04-18 and 04-20.

² Select motor & gearbox unit from pages 04-24 and 04-25.

³ Select correct port & driver kit from page 04-23.

⁴ Select farm duty motor from section 20.



MODEL 730 - 3" COMPONENTS - 30° ENTRANCE SYSTEM

REFER TO 30° ENTRANCE DRAWING PAGE 04-28

	CATALOG NUMBER	COMPONENT DESCRIPTION	HORIZONTAL INSIDE LENGTH OF SYSTEM										
			FT	10	20	30	40	50	60	70	80	90	100
			M	3.1	6.1	9.2	12.2	15.3	18.3	21.4	24.4	27.5	30.5
ORDER THE INDICATED QTY	LINE COMPONENTS:												
	730499	45° Formed PVC Tube	1	1	1	1	1	1	1	1	1	1	
	730434	10' Straight PVC Tube	2	3	4	5	6	7	8	9	10	11	
	730415	PVC Cement - 1/2 Pint	1	1	1	1	1	1	1	1	2	2	
	730440	2.38" OD Auger (feet)	30	40	50	60	70	80	90	100	110	120	
	SELECT ¹	Discharge Head	1	1	1	1	1	1	1	1	1	1	
DIRECT OR BELT DRIVE UNIT	DIRECT DRIVE UNIT:												
	SELECT ²	.50 HP Direct Drive	1	1	1	1	1	1	1	1	0	0	
	SELECT ²	.75 HP Direct Drive	0	0	0	0	0	0	0	0	1	1	
	SELECT ²	1.0 HP Direct Drive	0	0	0	0	0	0	0	0	0	0	
	SELECT ³	Port & Driver Kit	1	1	1	1	1	1	1	1	1	1	
	V-BELT DRIVE UNIT:												
	713230	V-Belt Drive Unit	1	1	1	1	1	1	1	1	1	1	
SELECT ³	Port & Driver Kit	1	1	1	1	1	1	1	1	1	1		
SELECT ⁴	Farm Duty Motor (see HP above)	1	1	1	1	1	1	1	1	1	1		
ORDER IF NEEDED	OPTIONAL SUSPENSION (CHOOSE HANGERS OR CHAIN):												
	VEN91504C	5/16" x 3.5" Screw Hook	3	5	8	10	13	15	18	20	23	25	
	713220 or 713223	Formed Hanger Galv (713220) or SS (713223)	3	5	8	10	13	15	18	20	23	25	
	820099	#2 Hanger Chain (feet)	8	13	20	25	33	38	45	50	58	63	

	CATALOG NUMBER	COMPONENT DESCRIPTION	HORIZONTAL INSIDE LENGTH OF SYSTEM										
			FT	110	120	130	140	150	160	170	180	190	200
			M	33.6	36.6	39.7	42.7	45.8	48.8	51.9	54.9	58	61
ORDER THE INDICATED QTY	LINE COMPONENTS:												
	730499	45° Formed PVC Tube	1	1	1	1	1	1	1	1	1	1	
	730434	10' Straight PVC Tube	12	13	14	15	16	17	18	19	20	21	
	730415	PVC Cement - 1/2 Pint	2	2	2	2	2	2	2	2	3	3	
	730440	2.38" OD Auger (feet)	130	140	150	160	170	180	190	200	210	220	
	SELECT ¹	Discharge Head	1	1	1	1	1	1	1	1	1	1	
DIRECT OR BELT DRIVE UNIT	DIRECT DRIVE UNIT:												
	SELECT ²	.50 HP Direct Drive	0	0	0	0	0	0	0	0	0	0	
	SELECT ²	.75 HP Direct Drive	1	1	1	1	1	0	0	0	0	0	
	SELECT ²	1.0 HP Direct Drive	0	0	0	0	0	1	1	1	1	1	
	SELECT ³	Port & Driver Kit	1	1	1	1	1	1	1	1	1	1	
	V-BELT DRIVE UNIT:												
	713230	V-Belt Drive Unit	1	1	1	1	1	1	1	1	1	1	
SELECT ³	Port & Driver Kit	1	1	1	1	1	1	1	1	1	1		
SELECT ⁴	Farm Duty Motor (see HP above)	1	1	1	1	1	1	1	1	1	1		
ORDER IF NEEDED	OPTIONAL SUSPENSION (CHOOSE HANGERS OR CHAIN):												
	VEN91504C	5/16" x 3.5" Screw Hook	28	30	33	35	38	40	43	45	48	50	
	713220 or 713223	Formed Hanger Galv (713220) or SS (713223)	28	30	33	35	38	40	43	45	48	50	
	820099	#2 Hanger Chain (feet)	70	75	83	88	95	100	108	113	120	125	

¹ Select steel or poly discharge head from pages 04-18 and 04-20.

² Select motor & gearbox unit from pages 04-24 and 04-25.

³ Select correct port & driver kit from page 04-23.

⁴ Select farm duty motor from section 20.



MODEL 730 - 3" COMPONENTS - PASS-THRU SYSTEM

REFER TO PASS-THRU SYSTEM DRAWING PAGE 04-29

	CATALOG NUMBER	COMPONENT DESCRIPTION	HORIZONTAL INSIDE LENGTH OF SYSTEM										
			FT	10	20	30	40	50	60	70	80	90	100
			M	3.1	6.1	9.2	12.2	15.3	18.3	21.4	24.4	27.5	30.5
ORDER THE INDICATED QTY	LINE COMPONENTS:												
	730499	45° Formed PVC Tube	2	2	2	2	2	2	2	2	2	2	
	730434	10' Straight PVC Tube	3	4	5	6	7	8	9	10	11	12	
	730415	PVC Cement - 1/2 Pint	1	1	1	1	1	1	1	2	2	2	
	730440	2.38" OD Auger (feet)	50	60	70	80	90	100	110	120	130	140	
	SELECT ¹	Discharge Head	1	1	1	1	1	1	1	1	1	1	
DIRECT OR BELT DRIVE UNIT	DIRECT DRIVE UNIT:												
	SELECT ²	.50 HP Direct Drive	1	1	1	0	0	0	0	0	0	0	
	SELECT ²	.75 HP Direct Drive	0	0	0	1	1	1	1	1	1	0	
	SELECT ²	1.0 HP Direct Drive	0	0	0	0	0	0	0	0	0	1	
	SELECT ³	Port & Driver Kit	1	1	1	1	1	1	1	1	1	1	
	V-BELT DRIVE UNIT:												
	713230	V-Belt Drive Unit	1	1	1	1	1	1	1	1	1	1	
	SELECT ³	Port & Driver Kit	1	1	1	1	1	1	1	1	1		
	SELECT ⁴	Farm Duty Motor (see HP above)	1	1	1	1	1	1	1	1	1		
ORDER IF NEEDED	OPTIONAL SUSPENSION (CHOOSE HANGERS OR CHAIN):												
	VEN91504C	5/16" x 3.5" Screw Hook	3	5	8	10	13	15	18	20	23	25	
	713220 or 713223	Formed Hanger Galv (713220) or SS (713223)	3	5	8	10	13	15	18	20	23	25	
	820099	#2 Hanger Chain (feet)	8	13	20	25	33	38	45	50	58	63	

	CATALOG NUMBER	COMPONENT DESCRIPTION	HORIZONTAL INSIDE LENGTH OF SYSTEM					
			FT	110	120	130	140	150
			M	33.6	36.6	39.7	42.7	45.8
ORDER THE INDICATED QTY	LINE COMPONENTS:							
	730499	45° Formed PVC Tube	2	2	2	2	2	
	730434	10' Straight PVC Tube	13	14	15	16	17	
	730415	PVC Cement - 1/2 Pint	2	2	2	2	2	
	730440	2.38" OD Auger (feet)	150	160	170	180	190	
	SELECT ¹	Discharge Head	1	1	1	1	1	
DIRECT OR BELT DRIVE UNIT	DIRECT DRIVE UNIT:							
	SELECT ²	.50 HP Direct Drive	0	0	0	0	0	
	SELECT ²	.75 HP Direct Drive	0	0	0	0	0	
	SELECT ²	1.0 HP Direct Drive	1	1	1	1	0	
	SELECT ³	Port & Driver Kit	1	1	1	1	1	
	V-BELT DRIVE UNIT:							
	713230	V-Belt Drive Unit	1	1	1	1	1	
	SELECT ³	Port & Driver Kit	1	1	1	1	1	
	SELECT ⁴	Farm Duty Motor (see HP above)	1	1	1	1	1	
ORDER IF NEEDED	OPTIONAL SUSPENSION (CHOOSE HANGERS OR CHAIN):							
	VEN91504C	5/16" x 3.5" Screw Hook	28	30	33	35	38	
	713220 or 713223	Formed Hanger Galv (713220) or SS (713223)	28	30	33	35	38	
	820099	#2 Hanger Chain (feet)	70	75	83	88	95	

¹ Select steel or poly discharge head from pages 04-18 and 04-20.

² Select motor & gearbox unit from pages 04-24 and 04-25.

³ Select correct port & driver kit from page 04-23.

⁴ Select farm duty motor from section 20.

MODEL 730 - 3" COMPONENTS - EXTENDED LENGTH SYSTEM

REFER TO EXTENDED LENGTH SYSTEM DRAWING ON PAGE 04-30

	CATALOG NUMBER	COMPONENT DESCRIPTION	HORIZONTAL INSIDE LENGTH OF SYSTEM															
			FT	10	20	30	40	50	60	70	80	90	100	110	120	130		
			M	3.1	6.1	9.2	12	15	18.3	21	24	28	31	34	37	40		
ORDER THE INDICATED QTY	LINE COMPONENTS:																	
	730944	Lower Boot Less Slide Valve	1	1	1	1	1	1	1	1	1	1	1	1	1	1	1	
	SELECT ⁴	Adapter Plate	1	1	1	1	1	1	1	1	1	1	1	1	1	1	1	
	730434	10' Straight PVC Tube	1	2	3	4	5	6	7	8	9	10	11	12	13			
	730415	PVC Cement - 1/2 Pint	1	1	1	1	1	1	1	1	1	2	2	2	2			
	730440	2.38" OD Auger (feet)	20	30	40	50	60	70	80	90	100	110	120	130	140			
SELECT ¹	Discharge Head	1	1	1	1	1	1	1	1	1	1	1	1	1	1	1	1	
DRIVE UNIT	DIRECT DRIVE UNIT:																	
	SELECT ²	.50 HP Direct Drive	1	1	1	1	1	1	1	1	1	1	1	1	0	0		
	SELECT ²	.75 HP Direct Drive	0	0	0	0	0	0	0	0	0	0	0	0	1	1		
	SELECT ²	1.0 HP Direct Drive	0	0	0	0	0	0	0	0	0	0	0	0	0	0		
	SELECT ³	Port & Driver Kit	1	1	1	1	1	1	1	1	1	1	1	1	1	1	1	1
ORDER IF NEEDED	OPTIONAL SUSPENSION (CHOOSE HANGERS OR CHAIN):																	
	VEN91504C	5/16" x 3.5" Screw Hook	3	5	8	10	13	15	18	20	23	25	28	30	33			
	713220 or 713223	Formed Hanger Galv (713220) or SS (713223)	3	5	8	10	13	15	18	20	23	25	28	30	33			
	820099	#2 Hanger Chain (feet)	8	13	20	25	33	38	45	50	58	63	70	75	83			

	CATALOG NUMBER	COMPONENT DESCRIPTION	HORIZONTAL INSIDE LENGTH OF SYSTEM														
			FT	140	150	160	170	180	190	200	210	220	230	240	250		
			M	43	46	49	52	55	58	61	64	67	70	73	76		
ORDER THE INDICATED QTY	LINE COMPONENTS:																
	730944	Lower Boot Less Slide Valve	1	1	1	1	1	1	1	1	1	1	1	1	1		
	SELECT ⁴	Adapter Plate	1	1	1	1	1	1	1	1	1	1	1	1	1		
	730434	10' Straight PVC Tube	14	15	16	17	18	19	20	21	22	23	24	25			
	730415	PVC Cement - 1/2 Pint	2	2	2	2	2	2	3	3	3	3	3	3			
	730440	2.38" OD Auger (feet)	150	160	170	180	190	200	210	220	230	240	250	260			
SELECT ¹	Discharge Head	1	1	1	1	1	1	1	1	1	1	1	1	1	1	1	
ORDER DIRECT OR V-BELT DRIVE	DIRECT DRIVE UNIT:																
	SELECT ²	.50 HP Direct Drive	0	0	0	0	0	0	0	0	0	0	0	0	0		
	SELECT ²	.75 HP Direct Drive	1	1	1	1	1	0	0	0	0	0	0	0			
	SELECT ²	1.0 HP Direct Drive	0	0	0	0	0	1	1	1	1	1	1	0			
	SELECT ³	Port & Driver Kit	1	1	1	1	1	1	1	1	1	1	1	1	1	1	1
ORDER IF NEEDED	OPTIONAL SUSPENSION (CHOOSE HANGERS OR CHAIN):																
	VEN91504C	5/16" x 3.5" Screw Hook	35	38	40	43	45	48	50	53	55	58	60	63			
	713220 or 713223	Formed Hanger Galv (713220) or SS (713223)	35	38	40	43	45	48	50	53	55	58	60	63			
	820099	#2 Hanger Chain (feet)	88	95	100	108	113	120	125	133	138	145	150	158			

¹ Select steel or poly discharge head from pages 04-18 and 04-20.

² Select motor & gearbox unit from pages 04-25 and 04-25 (See recommendation on selecting drive RPMs on page 04-30).

³ Select correct port & driver kit from page 04-23.

⁴ Select adapter plate (for steel or poly discharge head) from page 04-07.



MODEL 735HV - 3.5" COMPONENTS - 45° ENTRANCE SYSTEM

REFER TO 45° ENTRANCE DRAWING PAGE 04-27

CATALOG NUMBER	COMPONENT DESCRIPTION	HORIZONTAL INSIDE LENGTH OF SYSTEM										
		FT	10	20	30	40	50	60	70	80	90	100
		M	3.1	6.1	9.2	12.2	15.3	18.3	21.4	24.4	27.5	30.5
ORDER THE INDICATED QTY	LINE COMPONENTS:											
	735499	45° Formed PVC Tube	2	2	2	2	2	2	2	2	2	2
	735434	10' Straight PVC Tube	2	3	4	5	6	7	8	9	10	11
	730415	PVC Cement - 1/2 Pint	1	1	1	1	1	1	1	1	2	2
	735440	2.71" OD Auger (feet)	30	40	50	60	70	80	90	100	110	120
	SELECT ¹	Discharge Head	1	1	1	1	1	1	1	1	1	1
DIRECT OR BELT DRIVE UNIT	DIRECT DRIVE UNIT:											
	SELECT ²	.50 HP Direct Drive	1	1	1	0	0	0	0	0	0	0
	SELECT ²	.75 HP Direct Drive	0	0	0	1	1	1	1	1	1	0
	SELECT ²	1.0 HP Direct Drive	0	0	0	0	0	0	0	0	0	1
	SELECT ³	Port & Driver Kit	1	1	1	1	1	1	1	1	1	1
	V-BELT DRIVE UNIT:											
	713230	V-Belt Drive Unit	1	1	1	1	1	1	1	1	1	1
SELECT ³	Port & Driver Kit	1	1	1	1	1	1	1	1	1	1	
SELECT ⁴	Farm Duty Motor (see HP above)	1	1	1	1	1	1	1	1	1	1	
ORDER IF NEEDED	OPTIONAL SUSPENSION (CHOOSE HANGERS OR CHAIN):											
	VEN91504C	5/16" x 3.5" Screw Hook	3	5	8	10	13	15	18	20	23	25
	735220	Formed Hanger	3	5	8	10	13	15	18	20	23	25
	820099	#2 Hanger Chain (feet)	8	13	20	25	33	38	45	50	58	63

CATALOG NUMBER	COMPONENT DESCRIPTION	HORIZONTAL INSIDE LENGTH OF SYSTEM					
		FT	110	120	130	140	150
		M	33.6	36.6	39.7	42.7	45.8
ORDER THE INDICATED QTY	LINE COMPONENTS:						
	735499	45° Formed PVC Tube	2	2	2	2	2
	735434	10' Straight PVC Tube	12	13	14	15	16
	730415	PVC Cement - 1/2 Pint	2	2	2	2	2
	735440	2.71" OD Auger (feet)	130	140	150	160	170
	SELECT ¹	Discharge Head	1	1	1	1	1
DIRECT OR BELT DRIVE UNIT	DIRECT DRIVE UNIT:						
	SELECT ²	.50 HP Direct Drive	0	0	0	0	0
	SELECT ²	.75 HP Direct Drive	0	0	0	0	0
	SELECT ²	1.0 HP Direct Drive	1	1	1	1	1
	SELECT ³	Port & Driver Kit	1	1	1	1	1
	V-BELT DRIVE UNIT:						
	713230	V-Belt Drive Unit	1	1	1	1	1
SELECT ³	Port & Driver Kit	1	1	1	1	1	
SELECT ⁴	Farm Duty Motor (see HP above)	1	1	1	1	1	
ORDER IF NEEDED	OPTIONAL SUSPENSION (CHOOSE HANGERS OR CHAIN):						
	VEN91504C	5/16" x 3.5" Screw Hook	28	30	33	35	38
	735220	Formed Hanger	28	30	33	35	38
	820099	#2 Hanger Chain (feet)	70	75	83	88	95

¹ Select steel or poly discharge head from pages 04-18 and 04-20.

² Select motor & gearbox unit from pages 04-24 and 04-25.

³ Select correct port & driver kit from page 04-23.

⁴ Select farm duty motor from section 20.



MODEL 735HV - 3.5" COMPONENTS - 30° ENTRANCE SYSTEM

REFER TO 30° ENTRANCE DRAWING PAGE 04-28

CATALOG NUMBER	COMPONENT DESCRIPTION	HORIZONTAL INSIDE LENGTH OF SYSTEM										
		FT	10	20	30	40	50	60	70	80	90	100
		M	3.1	6.1	9.2	12.2	15.3	18.3	21.4	24.4	27.5	30.5
ORDER THE INDICATED QTY	LINE COMPONENTS:											
	735499	45° Formed PVC Tube	1	1	1	1	1	1	1	1	1	1
	735434	10' Straight PVC Tube	2	3	4	5	6	7	8	9	10	11
	730415	PVC Cement - 1/2 Pint	1	1	1	1	1	1	1	1	2	2
	735440	2.71" OD Auger (feet)	30	40	50	60	70	80	90	100	110	120
	SELECT ¹	Discharge Head	1	1	1	1	1	1	1	1	1	1
DIRECT OR BELT DRIVE UNIT	DIRECT DRIVE UNIT:											
	SELECT ²	.50 HP Direct Drive	1	1	1	0	0	0	0	0	0	0
	SELECT ²	.75 HP Direct Drive	0	0	0	1	1	1	1	1	1	0
	SELECT ²	1.0 HP Direct Drive	0	0	0	0	0	0	0	0	0	1
	SELECT ³	Port & Driver Kit	1	1	1	1	1	1	1	1	1	1
	V-BELT DRIVE UNIT:											
	713230	V-Belt Drive Unit	1	1	1	1	1	1	1	1	1	1
SELECT ³	Port & Driver Kit	1	1	1	1	1	1	1	1	1	1	
SELECT ⁴	Farm Duty Motor (see HP above)	1	1	1	1	1	1	1	1	1	1	
ORDER IF NEEDED	OPTIONAL SUSPENSION (CHOOSE HANGERS OR CHAIN):											
	VEN91504C	5/16" x 3.5" Screw Hook	3	5	8	10	13	15	18	20	23	25
	735220	Formed Hanger	3	5	8	10	13	15	18	20	23	25
	820099	#2 Hanger Chain (feet)	8	13	20	25	33	38	45	50	58	63

CATALOG NUMBER	COMPONENT DESCRIPTION	HORIZONTAL INSIDE LENGTH OF SYSTEM					
		FT	110	120	130	140	150
		M	33.6	36.6	39.7	42.7	45.8
ORDER THE INDICATED QTY	LINE COMPONENTS:						
	735499	45° Formed PVC Tube	1	1	1	1	1
	735434	10' Straight PVC Tube	12	13	14	15	16
	730415	PVC Cement - 1/2 Pint	2	2	2	2	2
	735440	2.71" OD Auger (feet)	130	140	150	160	170
	SELECT ¹	Discharge Head	1	1	1	1	1
DIRECT OR BELT DRIVE UNIT	DIRECT DRIVE UNIT:						
	SELECT ²	.50 HP Direct Drive	0	0	0	0	0
	SELECT ²	.75 HP Direct Drive	0	0	0	0	0
	SELECT ²	1.0 HP Direct Drive	1	1	1	1	1
	SELECT ³	Port & Driver Kit	1	1	1	1	1
	V-BELT DRIVE UNIT:						
	713230	V-Belt Drive Unit	1	1	1	1	1
SELECT ³	Port & Driver Kit	1	1	1	1	1	
SELECT ⁴	Farm Duty Motor (see HP above)	1	1	1	1	1	
ORDER IF NEEDED	OPTIONAL SUSPENSION (CHOOSE HANGERS OR CHAIN):						
	VEN91504C	5/16" x 3.5" Screw Hook	28	30	33	35	38
	735220	Formed Hanger	28	30	33	35	38
	820099	#2 Hanger Chain (feet)	70	75	83	88	95

¹ Select steel or poly discharge head from pages 04-18 and 04-20.

² Select motor & gearbox unit from pages 04-24 and 04-25.

³ Select correct port & driver kit from page 04-23.

⁴ Select farm duty motor from section 20.



MODEL 735HV - 3.5" COMPONENTS - PASS-THRU SYSTEM

REFER TO PASS-THRU ENTRANCE DRAWING PAGE 04-29

CATALOG NUMBER	COMPONENT DESCRIPTION	HORIZONTAL INSIDE LENGTH OF SYSTEM										
		FT	10	20	30	40	50	60	70	80	90	100
		M	3.1	6.1	9.2	12.2	15.3	18.3	21.4	24.4	27.5	30.5
ORDER THE INDICATED QTY	LINE COMPONENTS:											
	735499	45° Formed PVC Tube	2	2	2	2	2	2	2	2	2	2
	735434	10' Straight PVC Tube	3	4	5	6	7	8	9	10	11	12
	730415	PVC Cement - 1/2 Pint	1	1	1	1	1	1	1	2	2	2
	735440	2.71" OD Auger (feet)	50	60	70	80	90	100	110	120	130	140
	SELECT ¹	Discharge Head	1	1	1	1	1	1	1	1	1	1
DIRECT OR BELT DRIVE UNIT	DIRECT DRIVE UNIT:											
	SELECT ²	.50 HP Direct Drive	0	0	0	0	0	0	0	0	0	0
	SELECT ²	.75 HP Direct Drive	1	1	1	0	0	0	0	0	0	0
	SELECT ²	1.0 HP Direct Drive	0	0	0	1	1	1	1	1	1	0
	SELECT ³	Port & Driver Kit	1	1	1	1	1	1	1	1	1	1
	V-BELT DRIVE UNIT:											
	713230	V-Belt Drive Unit	1	1	1	1	1	1	1	1	1	1
	SELECT ³	Port & Driver Kit	1	1	1	1	1	1	1	1	1	1
SELECT ⁴	Farm Duty Motor (see HP above)	1	1	1	1	1	1	1	1	1	1	
ORDER IF NEEDED	OPTIONAL SUSPENSION (CHOOSE HANGERS OR CHAIN):											
	VEN91504C	5/16" x 3.5" Screw Hook	3	5	8	10	13	15	18	20	23	25
	735220	Formed Hanger	3	5	8	10	13	15	18	20	23	25
	820099	#2 Hanger Chain (feet)	8	13	20	25	33	38	45	50	58	63

¹ Select steel or poly discharge head from pages 04-18 and 04-20.

² Select motor & gearbox unit from pages 04-24 and 04-25.

³ Select correct port & driver kit from page 04-23.

⁴ Select farm duty motor from section 20.



MODEL 735HV - 3.5" COMPONENTS - EXTENDED LENGTH SYSTEM

REFER TO EXTENDED LENGTH SYSTEM DRAWING ON PAGE 04-30

CATALOG NUMBER	COMPONENT DESCRIPTION	HORIZONTAL INSIDE LENGTH OF SYSTEM										
		FT	10	20	30	40	50	60	70	80	90	100
		M	3.1	6.1	9.2	12.2	15.3	18.3	21.4	24.4	27.5	30.5
ORDER THE INDICATED QTY	LINE COMPONENTS:											
	735994	Lower Boot Less Slide Valve	1	1	1	1	1	1	1	1	1	1
	SELECT ⁴	Adapter Plate	1	1	1	1	1	1	1	1	1	1
	735434	10' Straight PVC Tube	1	2	3	4	5	6	7	8	9	10
	730415	PVC Cement - 1/2 Pint	1	1	1	1	1	1	1	1	1	2
	735440	2.71" OD Auger (feet)	20	30	40	50	60	70	80	90	100	110
SELECT ¹	Discharge Head	1	1	1	1	1	1	1	1	1	1	
DRIVE UNIT	DIRECT DRIVE UNIT:											
	SELECT ²	.50 HP Direct Drive	1	1	1	1	1	0	0	0	0	0
	SELECT ²	.75 HP Direct Drive	0	0	0	0	0	1	1	1	1	1
	SELECT ²	1.0 HP Direct Drive	0	0	0	0	0	0	0	0	0	0
SELECT ³	Port & Driver Kit	1	1	1	1	1	1	1	1	1	1	
ORDER IF NEEDED	OPTIONAL SUSPENSION (CHOOSE HANGERS OR CHAIN):											
	VEN91504C	5/16" x 3.5" Screw Hook	3	5	8	10	13	15	18	20	23	25
	735220	Formed Hanger	3	5	8	10	13	15	18	20	23	25
	820099	#2 Hanger Chain (feet)	8	13	20	25	33	38	45	50	58	63

CATALOG NUMBER	COMPONENT DESCRIPTION	HORIZONTAL INSIDE LENGTH OF SYSTEM									
		FT	110	120	130	140	150	160	170	180	190
		M	33.6	36.6	39.7	42.7	45.8	48.8	51.9	54.9	58
ORDER THE INDICATED QTY	LINE COMPONENTS:										
	735994	Lower Boot Less Slide Valve	1	1	1	1	1	1	1	1	1
	SELECT ⁴	Adapter Plate	1	1	1	1	1	1	1	1	1
	735434	10' Straight PVC Tube	11	12	13	14	15	16	17	18	19
	730415	PVC Cement - 1/2 Pint	2	2	2	2	2	2	2	2	2
	735440	2.71" OD Auger (feet)	120	130	140	150	160	170	180	190	200
SELECT ¹	Discharge Head	1	1	1	1	1	1	1	1	1	
DRIVE UNIT	DIRECT DRIVE UNIT:										
	SELECT ²	.50 HP Direct Drive	0	0	0	0	0	0	0	0	0
	SELECT ²	.75 HP Direct Drive	1	0	0	0	0	0	0	0	0
	SELECT ²	1.0 HP Direct Drive	0	1	1	1	1	1	1	1	1
SELECT ³	Port & Driver Kit	1	1	1	1	1	1	1	1	1	
ORDER IF NEEDED	OPTIONAL SUSPENSION (CHOOSE HANGERS OR CHAIN):										
	VEN91504C	5/16" x 3.5" Screw Hook	28	30	33	35	38	40	43	45	48
	735220	Formed Hanger	28	30	33	35	38	40	43	45	48
820099	#2 Hanger Chain (feet)	70	75	83	88	95	100	108	113	120	

¹ Select steel or poly discharge head from pages 04-18 and 04-20.

² Select motor & gearbox unit from pages 04-24 and 04-25 (See recommendation on selecting drive RPMs on page 04-30).

³ Select correct port & driver kit from page 04-23.

⁴ Select adapter plate (for steel or poly discharge head) from page 04-07.



MODEL 735HM - 3.5" COMPONENTS - 45° ENTRANCE SYSTEM

REFER TO 45° ENTRANCE DRAWING PAGE 04-27

	CATALOG NUMBER	COMPONENT DESCRIPTION	HORIZONTAL INSIDE LENGTH OF SYSTEM										
			FT	10	20	30	40	50	60	70	80	90	100
			M	3.1	6.1	9.2	12.2	15.3	18.3	21.4	24.4	27.5	30.5
ORDER THE INDICATED QTY	LINE COMPONENTS:												
	735499	45° Formed PVC Tube	2	2	2	2	2	2	2	2	2	2	
	735434	10' Straight PVC Tube	2	3	4	5	6	7	8	9	10	11	
	730415	PVC Cement - 1/2 Pint	1	1	1	1	1	1	1	1	2	2	
	730440	2.38" OD Auger (feet)	30	40	50	60	70	80	90	100	110	120	
	SELECT ¹	Discharge Head	1	1	1	1	1	1	1	1	1	1	
DIRECT OR BELT DRIVE UNIT	DIRECT DRIVE UNIT:												
	SELECT ²	.50 HP Direct Drive	1	1	1	0	0	0	0	0	0	0	
	SELECT ²	.75 HP Direct Drive	0	0	0	1	1	1	1	1	1	0	
	SELECT ²	1.0 HP Direct Drive	0	0	0	0	0	0	0	0	0	1	
	SELECT ³	Port & Driver Kit	1	1	1	1	1	1	1	1	1	1	
	V-BELT DRIVE UNIT:												
	713230	V-Belt Drive Unit	1	1	1	1	1	1	1	1	1	1	
	SELECT ³	Port & Driver Kit	1	1	1	1	1	1	1	1	1	1	
	SELECT ⁴	Farm Duty Motor (see HP above)	1	1	1	1	1	1	1	1	1	1	
ORDER IF NEEDED	OPTIONAL SUSPENSION (CHOOSE HANGERS OR CHAIN):												
	VEN91504C	5/16" x 3.5" Screw Hook	3	5	8	10	13	15	18	20	23	25	
	735220	Formed Hanger	3	5	8	10	13	15	18	20	23	25	
	820099	#2 Hanger Chain (feet)	8	13	20	25	33	38	45	50	58	63	

	CATALOG NUMBER	COMPONENT DESCRIPTION	HORIZONTAL INSIDE LENGTH OF SYSTEM					
			FT	110	120	130	140	150
			M	33.6	36.6	39.7	42.7	45.8
ORDER THE INDICATED QTY	LINE COMPONENTS:							
	735499	45° Formed PVC Tube	2	2	2	2	2	
	735434	10' Straight PVC Tube	12	13	14	15	16	
	730415	PVC Cement - 1/2 Pint	2	2	2	2	2	
	730440	2.38" OD Auger (feet)	130	140	150	160	170	
	SELECT ¹	Discharge Head	1	1	1	1	1	
DIRECT OR BELT DRIVE UNIT	DIRECT DRIVE UNIT:							
	SELECT ²	.50 HP Direct Drive	0	0	0	0	0	
	SELECT ²	.75 HP Direct Drive	0	0	0	0	0	
	SELECT ²	1.0 HP Direct Drive	1	1	1	1	1	
	SELECT ³	Port & Driver Kit	1	1	1	1	1	
	V-BELT DRIVE UNIT:							
	713230	V-Belt Drive Unit	1	1	1	1	1	
	SELECT ³	Port & Driver Kit	1	1	1	1	1	
	SELECT ⁴	Farm Duty Motor (see HP above)	1	1	1	1	1	
ORDER IF NEEDED	OPTIONAL SUSPENSION (CHOOSE HANGERS OR CHAIN):							
	VEN91504C	5/16" x 3.5" Screw Hook	28	30	33	35	38	
	735220	Formed Hanger	28	30	33	35	38	
	820099	#2 Hanger Chain (feet)	70	75	83	88	95	

¹ Select steel or poly discharge head from pages 04-18 and 04-20.

² Select motor & gearbox unit from pages 04-24 and 04-25.

³ Select correct port & driver kit from page 04-23.

⁴ Select farm duty motor from section 20.



MODEL 735HM - 3.5" COMPONENTS - 30° ENTRANCE SYSTEM

REFER TO 30° ENTRANCE DRAWING PAGE 04-28

	CATALOG NUMBER	COMPONENT DESCRIPTION	HORIZONTAL INSIDE LENGTH OF SYSTEM										
			FT	10	20	30	40	50	60	70	80	90	100
			M	3.1	6.1	9.2	12.2	15.3	18.3	21.4	24.4	27.5	30.5
ORDER THE INDICATED QTY	LINE COMPONENTS:												
	735499	45° Formed PVC Tube	1	1	1	1	1	1	1	1	1	1	
	735434	10' Straight PVC Tube	2	3	4	5	6	7	8	9	10	11	
	730415	PVC Cement - 1/2 Pint	1	1	1	1	1	1	1	1	2	2	
	730440	2.38" OD Auger (feet)	30	40	50	60	70	80	90	100	110	120	
	SELECT ¹	Discharge Head	1	1	1	1	1	1	1	1	1	1	
DIRECT OR BELT DRIVE UNIT	DIRECT DRIVE UNIT:												
	SELECT ²	.50 HP Direct Drive	1	1	1	0	0	0	0	0	0	0	
	SELECT ²	.75 HP Direct Drive	0	0	0	1	1	1	1	1	1	0	
	SELECT ²	1.0 HP Direct Drive	0	0	0	0	0	0	0	0	0	1	
	SELECT ³	Port & Driver Kit	1	1	1	1	1	1	1	1	1	1	
	V-BELT DRIVE UNIT:												
	713230	V-Belt Drive Unit	1	1	1	1	1	1	1	1	1	1	
	SELECT ³	Port & Driver Kit	1	1	1	1	1	1	1	1	1	1	
	SELECT ⁴	Farm Duty Motor (see HP above)	1	1	1	1	1	1	1	1	1	1	
ORDER IF NEEDED	OPTIONAL SUSPENSION (CHOOSE HANGERS OR CHAIN):												
	VEN91504C	5/16" x 3.5" Screw Hook	3	5	8	10	13	15	18	20	23	25	
	735220	Formed Hanger	3	5	8	10	13	15	18	20	23	25	
	820099	#2 Hanger Chain (feet)	8	13	20	25	33	38	45	50	58	63	

	CATALOG NUMBER	COMPONENT DESCRIPTION	HORIZONTAL INSIDE LENGTH OF SYSTEM					
			FT	110	120	130	140	150
			M	33.6	36.6	39.7	42.7	45.8
ORDER THE INDICATED QTY	LINE COMPONENTS:							
	735499	45° Formed PVC Tube	1	1	1	1	1	
	735434	10' Straight PVC Tube	12	13	14	15	16	
	730415	PVC Cement - 1/2 Pint	2	2	2	2	2	
	730440	2.38" OD Auger (feet)	130	140	150	160	170	
	SELECT ¹	Discharge Head	1	1	1	1	1	
DIRECT OR BELT DRIVE UNIT	DIRECT DRIVE UNIT:							
	SELECT ²	.50 HP Direct Drive	0	0	0	0	0	
	SELECT ²	.75 HP Direct Drive	0	0	0	0	0	
	SELECT ²	1.0 HP Direct Drive	1	1	1	1	1	
	SELECT ³	Port & Driver Kit	1	1	1	1	1	
	V-BELT DRIVE UNIT:							
	713230	V-Belt Drive Unit	1	1	1	1	1	
	SELECT ³	Port & Driver Kit	1	1	1	1	1	
	SELECT ⁴	Farm Duty Motor (see HP above)	1	1	1	1	1	
ORDER IF NEEDED	OPTIONAL SUSPENSION (CHOOSE HANGERS OR CHAIN):							
	VEN91504C	5/16" x 3.5" Screw Hook	28	30	33	35	38	
	735220	Formed Hanger	28	30	33	35	38	
	820099	#2 Hanger Chain (feet)	70	75	83	88	95	

¹ Select steel or poly discharge head from pages 04-18 and 04-20.

² Select motor & gearbox unit from pages 04-24 and 04-25.

³ Select correct port & driver kit from page 04-23.

⁴ Select farm duty motor from section 20.

MODEL 735HM - 3.5" COMPONENTS - PASS-THRU SYSTEM

REFER TO PASS-THRU ENTRANCE DRAWING PAGE 04-29

CATALOG NUMBER	COMPONENT DESCRIPTION	HORIZONTAL INSIDE LENGTH OF SYSTEM										
		FT	10	20	30	40	50	60	70	80	90	100
		M	3.1	6.1	9.2	12.2	15.3	18.3	21.4	24.4	27.5	30.5
ORDER THE INDICATED QTY	LINE COMPONENTS:											
	735499	45° Formed PVC Tube	2	2	2	2	2	2	2	2	2	2
	735434	10' Straight PVC Tube	3	3	4	5	6	7	8	9	10	11
	730415	PVC Cement - 1/2 Pint	1	1	1	1	1	1	1	1	2	2
	730440	2.38" OD Auger (feet)	50	60	70	80	90	100	110	120	130	140
	SELECT ¹	Discharge Head	1	1	1	1	1	1	1	1	1	1
DIRECT OR BELT DRIVE UNIT	DIRECT DRIVE UNIT:											
	SELECT ²	.50 HP Direct Drive	0	0	0	0	0	0	0	0	0	0
	SELECT ²	.75 HP Direct Drive	1	1	1	0	0	0	0	0	0	0
	SELECT ²	1.0 HP Direct Drive	0	0	0	1	1	1	1	1	1	0
	SELECT ³	Port & Driver Kit	1	1	1	1	1	1	1	1	1	1
	V-BELT DRIVE UNIT:											
	713230	V-Belt Drive Unit	1	1	1	1	1	1	1	1	1	1
SELECT ³	Port & Driver Kit	1	1	1	1	1	1	1	1	1	1	
SELECT ⁴	Farm Duty Motor (see HP above)	1	1	1	1	1	1	1	1	1	1	
ORDER IF NEEDED	OPTIONAL SUSPENSION (CHOOSE HANGERS OR CHAIN):											
	VEN91504C	5/16" x 3.5" Screw Hook	3	5	8	10	13	15	18	20	23	25
	735220	Formed Hanger	3	5	8	10	13	15	18	20	23	25
	820099	#2 Hanger Chain (feet)	8	13	20	25	33	38	45	50	58	63

¹ Select steel or poly discharge head from pages 04-18 and 04-20.

² Select motor & gearbox unit from pages 04-24 and 04-25.

³ Select correct port & driver kit from page 04-23.

⁴ Select farm duty motor from section 20.



MODEL 735HM - 3.5" COMPONENTS - EXTENDED LENGTH SYSTEM

REFER TO EXTENDED LENGTH SYSTEM DRAWING ON PAGE 04-30

CATALOG NUMBER	COMPONENT DESCRIPTION	HORIZONTAL INSIDE LENGTH OF SYSTEM										
		FT	10	20	30	40	50	60	70	80	90	100
		M	3.1	6.1	9.2	12.2	15.3	18.3	21.4	24.4	27.5	30.5
ORDER THE INDICATED QTY	LINE COMPONENTS:											
	735985	Lower Boot Less Slide Valve	1	1	1	1	1	1	1	1	1	1
	SELECT ⁴	Adapter Plate	1	1	1	1	1	1	1	1	1	1
	735434	10' Straight PVC Tube	1	2	3	4	5	6	7	8	9	10
	730415	PVC Cement - 1/2 Pint	1	1	1	1	1	1	1	1	1	2
	730440	2.38" OD Auger (feet)	20	30	40	50	60	70	80	90	100	120
SELECT ¹	Discharge Head	1	1	1	1	1	1	1	1	1	1	
DRIVE UNIT	DIRECT DRIVE UNIT:											
	SELECT ²	.50 HP Direct Drive	1	1	1	1	1	0	0	0	0	0
	SELECT ²	.75 HP Direct Drive	0	0	0	0	0	1	1	1	1	1
	SELECT ²	1.0 HP Direct Drive	0	0	0	0	0	0	0	0	0	0
SELECT ³	Port & Driver Kit	1	1	1	1	1	1	1	1	1	1	
ORDER IF NEEDED	OPTIONAL SUSPENSION (CHOOSE HANGERS OR CHAIN):											
	VEN91504C	5/16" x 3.5" Screw Hook	3	5	8	10	13	15	18	20	23	25
	735220	Formed Hanger	3	5	8	10	13	15	18	20	23	25
	820099	#2 Hanger Chain (feet)	8	13	20	25	33	38	45	50	58	63

CATALOG NUMBER	COMPONENT DESCRIPTION	HORIZONTAL INSIDE LENGTH OF SYSTEM									
		FT	110	120	130	140	150	160	170	180	190
		M	33.6	36.6	39.7	42.7	45.8	48.8	51.9	54.9	58
ORDER THE INDICATED QTY	LINE COMPONENTS:										
	735985	Lower Boot Less Slide Valve	1	1	1	1	1	1	1	1	1
	SELECT ⁴	Adapter Plate	1	1	1	1	1	1	1	1	1
	735434	10' Straight PVC Tube	11	12	13	14	15	16	17	18	19
	730415	PVC Cement - 1/2 Pint	2	2	2	2	2	2	2	2	2
	730440	2.38" OD Auger (feet)	120	130	140	150	160	170	180	190	200
SELECT ¹	Discharge Head	1	1	1	1	1	1	1	1	1	
DRIVE UNIT	DIRECT DRIVE UNIT:										
	SELECT ²	.50 HP Direct Drive	0	0	0	0	0	0	0	0	0
	SELECT ²	.75 HP Direct Drive	1	0	0	0	0	0	0	0	0
	SELECT ²	1.0 HP Direct Drive	0	1	1	1	1	1	1	1	0
SELECT ³	Port & Driver Kit	1	1	1	1	1	1	1	1	1	
ORDER IF NEEDED	OPTIONAL SUSPENSION (CHOOSE HANGERS OR CHAIN):										
	VEN91504C	5/16" x 3.5" Screw Hook	28	30	33	35	38	40	43	45	48
	735220	Formed Hanger	28	30	33	35	38	40	43	45	48
820099	#2 Hanger Chain (feet)	70	75	83	88	95	100	108	113	120	

¹ Select steel or poly discharge head from pages 04-18 and 04-20.

² Select motor & gearbox unit from pages 04-24 and 04-25 (See recommendation on selecting drive RPMs on page 04-30).

³ Select correct port & driver kit from page 04-23.

⁴ Select adapter plate (for steel or poly discharge head) from page 04-07.



SECTION 04.1

4.25" (108mm) 740 FLEXIBLE AUGER FILL SYSTEMS

IN THIS CATALOG SECTION

PAGE NUMBER	CONTENTS
04-51	Table of Contents & Fill System Disclaimers
04-52 & 04-53	Fill Systems Entrance Drawings / HP requirements & Application Notes
04-54	Upper Boot / Adapter
04-55	Lower Boots / Unloaders
04-56	Flexible Auger / Steel Tubes
04-57	Tubes, Hangers & Feed Screener
04-58	Drop Outlets & Downspout Tubes
04-59	Discharge Heads
04-60	Discharge Head Kits / Port & Driver Kits
04-61	Flag System Accessories / Switches & Controls
04-62	Direct Drive Table
04-63	Direct Drive Motors and Gear Box Units

REPAIRS

SEE REPAIR LISTING & REFERENCE MATERIAL IN SEPARATE CATALOG

VAL-CO SYSTEM DISCLAIMER

Recommendations, opinions, or advice given by Val-Co regarding equipment, systems, or installation shall be accepted at the user's own discretion and shall not constitute any warranty or guarantee of such products or their performance. Val-Co assumes no obligation or liability on account of any recommendation, opinions or advice as to the choice, installation, or use of products.

Before installation is made on any product or system, the user has a responsibility to research and comply with all federal, state, and local codes which may apply to the location and installation.

VAL-CO PRODUCT DISCLAIMER

Val-Co products are designed and manufactured to provide reliable performance. Even reliable products may experience occasional failures, due to variance of installation, environment, and the recognized life cycle of a product. Due to the possibility of failure, the user should provide adequate backup systems and an alarm or acknowledge willingness to accept the risk of loss.

WARRANTY

SEE CATALOG SECTION 01 TO REVIEW WARRANTY & DISCLAIMERS

4.25" (108mm) 740 FLEXIBLE AUGER FILL SYSTEMS

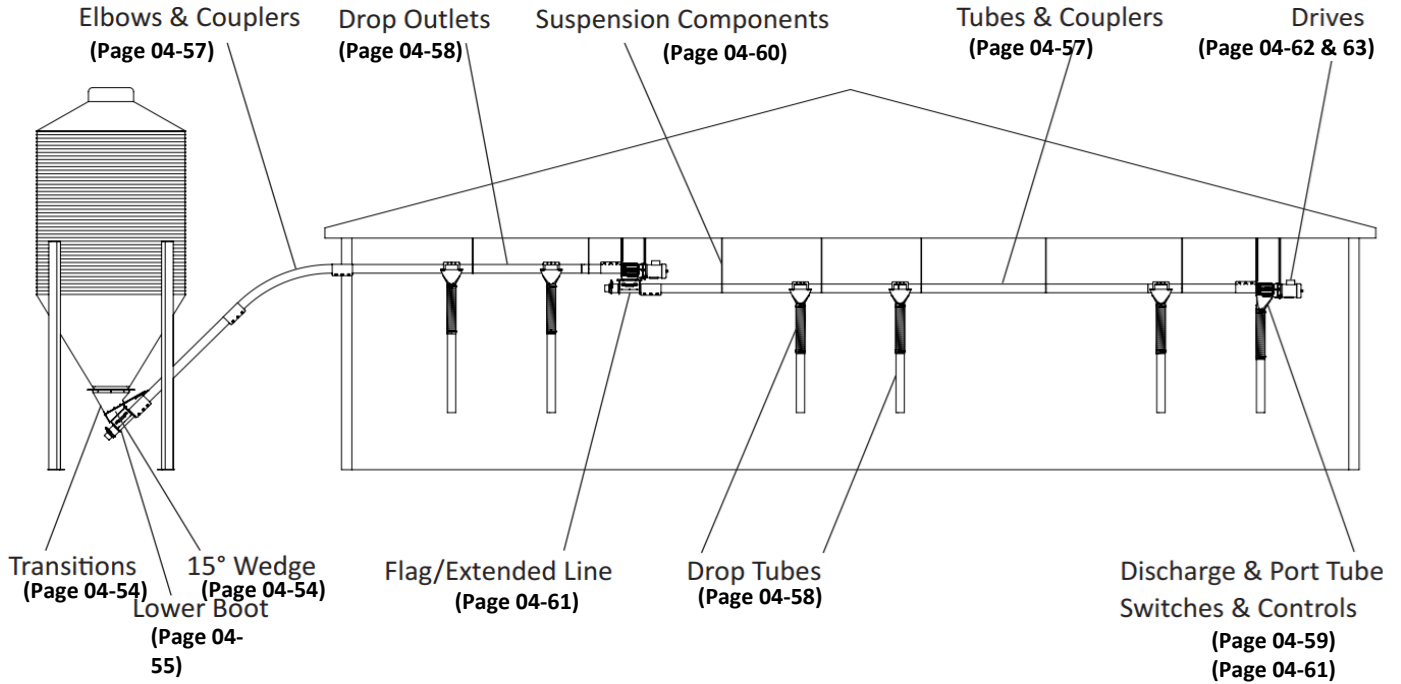

Model 740 Motor HP Requirements

Carrying capacities based on feed density of 40 lb./cu.ft

45° Entry System – 8' high max			Straight Extension System		
Max Length (Total Len. of System)	359 rpm (60Hz)	441 rpm (60Hz)	Max Length (Total Len. of System)	359 rpm (60Hz)	441 rpm (60Hz)
50'	0.75	1.0	75'	0.75	1.0
100'	1.0	1.5	135'	1.0	1.5
150'	1.5	2.00	185'	1.5	2.0
180'	2.0	NA	205'	2.0	NA

Application Notes

Length is **TOTAL** length of system

359rpm: HP requirements are given with estimated delivery rate at 220 lb/min maximum.

Can vary down depending on restrictor setting. (Density 40lb/cu. ft.)

441 rpm: HP requirements are given with estimated delivery rate at 250 lb/min maximum

Can vary down depending on restrictor setting. (Density 40lb/cu. ft.)

45° Entry System height restricted to 8'. For each additional ft, reduce max length by 5ft.

Reduce the line length by half for high moisture corn applications (18%-27%)

For all 740 systems:

Each additional 90° of bend, reduce the max length by 30'

Each additional 45° of bend, reduce the max length by 15'

Each additional 30° of bend, reduce the max length by 10'

Each additional 15° of bend, reduce the max length by 5'

Reduce max length by 30' for angles steeper than 45°. Maximum incline angle 60°

For each additional pass-thru bin, reduce the line length by 50'

Maximum recommended run time per day is 4 hours

Maximum recommended particle size 3/16" x 1/2"

Feed moisture content is less than 18%

Steel tubes are 4.25" (108mm) outside diameter

Flexible auger is 3.55" (90mm) outside diameter

4.25" (108mm) 740 FLEXIBLE AUGER FILL SYSTEMS

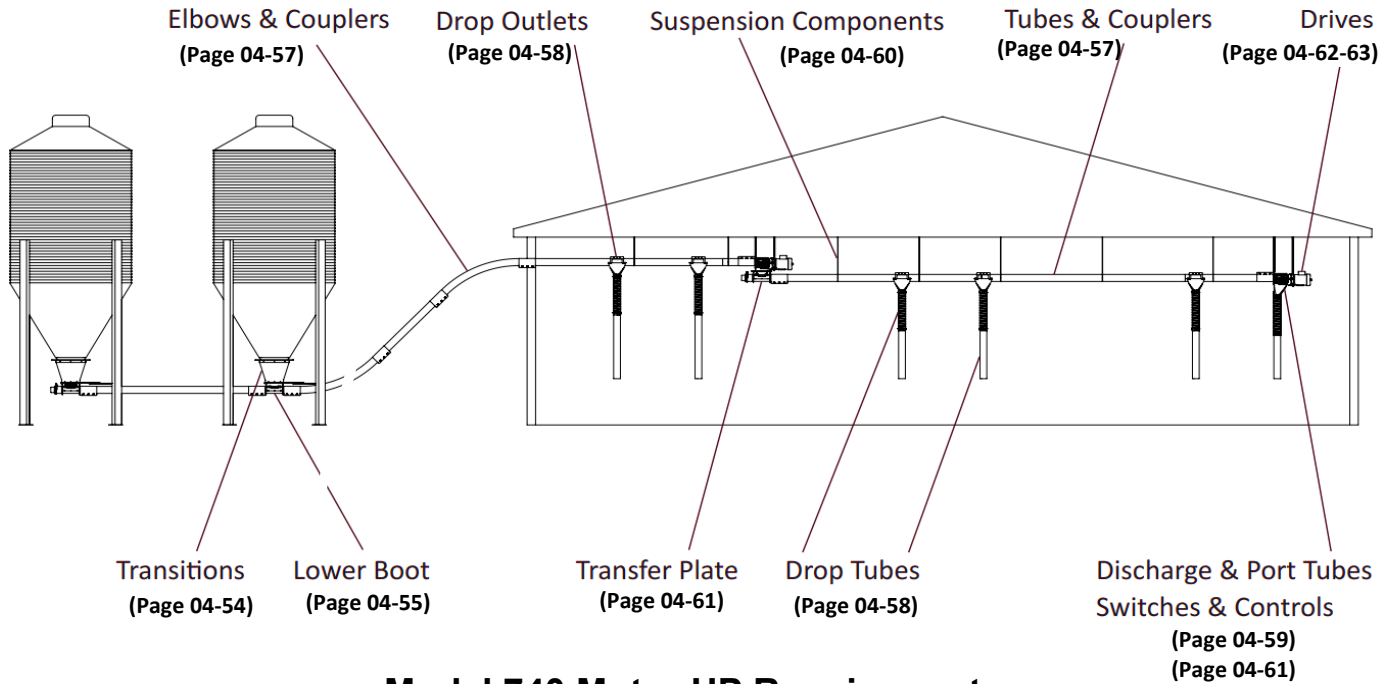

Model 740 Motor HP Requirements

Carrying capacities based on feed density of 40 lb./cu.ft

Single Pass-Thru 450 Entry System - 8' high max		
Max Length (Total Len. of System)	359 rpm (60Hz) 296 rpm (50Hz)	441 rpm (60Hz) 365 rpm (50Hz)
35'	1.0	1.5
85'	1.5	2.0
115'	2.0	NA

Straight Extension System		
Max Length (Total Len. of System)	359 rpm (60Hz) 296 rpm (50Hz)	441 rpm (60Hz) 365 rpm (50Hz)
75'	0.75	1.0
135'	1.0	1.5
185'	1.5	2.0
205'	2.0	NA

Application Notes

Length is **TOTAL** length of system

359rpm: HP requirements are given with estimated delivery rate at 220 lb/min maximum.

Can vary down depending on restrictor setting. (Density 40lb/cu. ft.)

441 rpm: HP requirements are given with estimated delivery rate at 250 lb/min maximum

Can vary down depending on restrictor setting. (Density 40lb/cu. ft.)

45° Entry System height restricted to 8'. For each additional ft, reduce max length by 5ft.

Reduce the line length by half for high moisture corn applications (18%-27%)

For all 740 systems:

Each additional 90° of bend, reduce the max length by 30'

Each additional 45° of bend, reduce the max length by 15'

Each additional 30° of bend, reduce the max length by 10'

Each additional 15° of bend, reduce the max length by 5'

Reduce max length by 30' for angles steeper than 45°. Maximum incline angle 60°

For each additional pass-thru bin, reduce the line length by 50'

Maximum recommended run time per day is 4 hours

Maximum recommended particle size 3/16" x 1/2"

Feed moisture content is less than 18%

Steel tubes are 4.25" (108mm) outside diameter

Flexible auger is 3.55" (90mm) outside diameter

UPPER BOOT TRANSITIONS & LOWER BOOT KITS

UPPER BOOT TRANSITIONS

CATALOG #	ITEM DESCRIPTION	SHIP WEIGHT		LIST PRICE
		LBS.	KG.	
500475	30 Degree Plastic Upper Boot Transition - Green	4.9	2.2	
500857	30 Degree Plastic Upper Boot Transition - Translucent	4.4	2.0	
500575	30 Degree Plastic Upper Boot Transition - Clear	4.6	2.1	
500485	Straight Plastic Upper Boot Transition - Green	5.5	2.5	
500855	Straight Plastic Upper Boot Transition - Translucent	5.6	2.5	
500585	Straight Plastic Upper Boot Transition - Clear	4.8	2.2	
700010	Straight Double Plastic Upper Boot Transition - Green	7.0	3.2	
501480	7.5° Transition Wedge Assembly Kit	2.9	1.4	
501470	15° Transition Wedge Assembly Kit (Use in conjunction with 30° Boot to achieve 45°)	4.4	2.0	

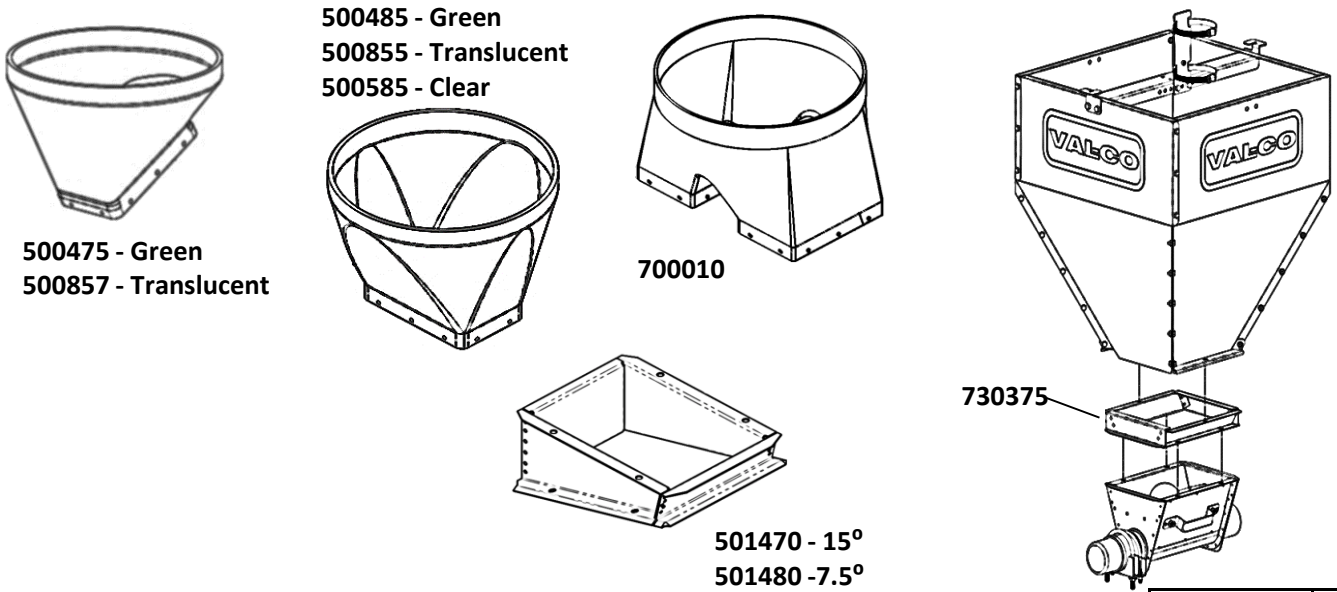

CATALOG #	ITEM DESCRIPTION	SHIP WEIGHT		LIST PRICE
		LBS.	KG.	
730375	Lower boot adapter to attach to Broiler Feed Hoppers	2.6	1.8	



MODEL 740 - 4.25" (108mm) LOWER BOOTS KITS

CATALOG #	ITEM DESCRIPTION	SHIP WEIGHT		LIST PRICE
		LBS.	KG.	
740531	4.25" Pass Thru Single Boot with Restrictor and Single Slide Valve	23.0	10.4	
740527	4.25" Single Outlet Lower Boot - Complete with Anchor & Bearing Kit - without Slide Valve	27.9	12.7	
740526	4.25" Single Outlet Lower Boot - Complete with Anchor & Bearing Kit and Single Slide Valve	43.8	19.9	
740532	4.25" Pass Thru Twin Boot with Restrictor and Single Slide Valve	40.9	18.5	
740533	4.25" Pass Thru Twin Boot Restrictor and Split Slide Valve	33.9	15.4	
740530	4.25" Twin Outlet Lower Boot - Complete with Anchor & Bearing Kits (2) - without Slide Valve	55.9	25.4	
740528	4.25" Twin Outlet Lower Boot - Complete with Anchor & Bearing Kits (2) and Single Slide Valve	60.9	9.8	
740529	4.25" Twin Outlet Lower Boot - Complete with Anchor & Bearing Kits (2) and Split Slide Valve	61.4	27.9	
740552	4.25" Twin Boot Plate Restrictor	1.3	0.6	

FLEXIBLE AUGER LOWER BOOT KIT COMPONENT REQUIREMENTS COMPONENT → SHIP WEIGHT → CATALOG NUMBER & DESCRIPTION →		Anchor & Bearing Kit	Slide Valve		Boot Housing		
		14.9	6.0	6.8	15.1	30.3	2.8
		740474 4.25"	500471 Single	500371 Twin/Split	740467 4.25" Single	740519 4.25" Twin ASM	740959 Restrictor
CATALOG # OF BOOT KIT	BOOT KIT DESCRIPTION	Quantity in Kit					
740526	4.25" Single Outlet Lower Boot - Single Slide Valve	1	1		1		
740527	4.25" Single Outlet Lower Boot - Less Slide Valve	1			1		
740528	4.25" Twin Outlet Lower Boot - Single Slide Valve	2	1			1	
740529	4.25" Twin Outlet Lower Boot - Split Slide Valve	2		1		1	
740530	4.25" Twin Outlet Lower Boot - Less Slide Valve	2				1	
740531	4.25" Pass Thru Single Boot with Restrictor and Single Slide Valve		1		1		1
740532	4.25" Pass Thru Twin Boot with Restrictor and Single Slide Valve		1			1	1
740533	4.25" Pass Thru Twin Boot Restrictor and Split Slide Valve			1			2



FLEXIBLE AUGER

MODEL 740 4.25" (108mm) FLEXIBLE AUGER

CATALOG #	ITEM DESCRIPTION	SHIP WEIGHT		LIST PRICE
		LBS.	KG.	
740440-0040	40' 3.55" O.D. Auger - Model 740HV Systems	51.6	23.4	
740440-0050	50' 3.55" O.D. Auger - Model 740HV Systems	81.0	36.7	
740440-0060	60' 3.55" O.D. Auger - Model 740HV Systems	106.0	48.1	
740440-0070	70' 3.55" O.D. Auger - Model 740HV Systems	90.3	41.0	
740440-0080	80' 3.55" O.D. Auger - Model 740HV Systems	103.2	46.8	
740440-0090	90' 3.55" O.D. Auger - Model 740HV Systems	116.1	52.7	
740440-0100	100' 3.55" O.D. Auger - Model 740HV Systems	129.0	58.5	
740440-0110	110' 3.55" O.D. Auger - Model 740HV Systems	141.9	64.4	
740440-0120	120' 3.55" O.D. Auger - Model 740HV Systems	154.8	70.2	
740440-0130	130' 3.55" O.D. Auger - Model 740HV Systems	167.7	76.1	
740440-0140	140' 3.55" O.D. Auger - Model 740HV Systems	180.6	81.9	
740440-0150	150' 3.55" O.D. Auger - Model 740HV Systems	193.5	87.8	
740440-0160	160' 3.55" O.D. Auger - Model 740HV Systems	206.4	93.6	
740440-0170	170' 3.55" O.D. Auger - Model 740HV Systems	250.0	113.4	
740440-0180	180' 3.55" O.D. Auger - Model 740HV Systems	232.2	105.3	
740440-0190	190' 3.55" O.D. Auger - Model 740HV Systems	245.1	111.2	
740440-0200	200' 3.55" O.D. Auger - Model 740HV Systems	308.0	139.7	
740440-0210	210' 3.55" O.D. Auger - Model 740HV Systems	318.0	144.2	

FLEXIBLE AUGER TUBES & HANGERS

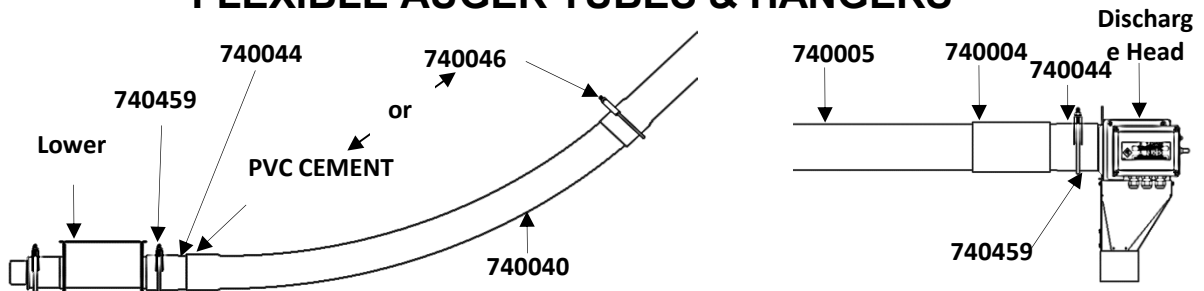

MODEL 740 (108mm) - 4.50" OD PVC

CATALOG #	ITEM DESCRIPTION	SHIP WEIGHT		LIST PRICE
		LBS.	KG.	
740005	10' PVC Tube - Belled, 4.50" OD	19.0	8.6	
740005-048	10' PVC Tube - Belled, 4.50" OD - Bundle of 48	21.4	9.7	
740040	4.50" OD x 45° PVC Elbow	10.0	4.5	
740040-024	4.50" OD x 45° PVC Elbow - Bundle of 24	21.4	9.7	
740044	Coupler - PVC to Metal	1.4	0.6	
740004	Coupler - PVC to PVC	1.3	0.6	
740004-016	Coupler - PVC to PVC - Carton of 16	21.4	9.7	
740459	4 1/2" U-Bolt Clamp - Zinc Plated	1.1	0.5	
740046	5" U-Bolt Clamp - Zinc Plated	1.1	0.5	

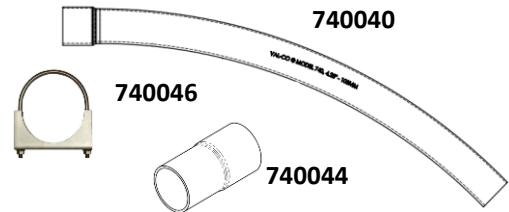

MODEL 740 (108mm)- 4.25" OD STEEL TUBES

740494	4.25" OD 45 Degree Steel Elbow (No Bell, Need 1 Coupler per Elbow)	15.8	7.1	
740482	4.25" OD 10' Straight Steel Tube (No Bell, Need 1 Coupler per Tube)	38.0	17.2	
740469	4.25" OD Steel Tube Coupler with Hardware	3.3	1.5	

PVC CEMENT

730415	PVC Cement - 1/2 Pint	1.0	0.5	
VG125-QT	PVC Cement - Quart	2.0	0.9	

MOTOR, GEARBOX AND
 DISCHARGE HEAD KITS ARE
 SOLD SEPARATELY

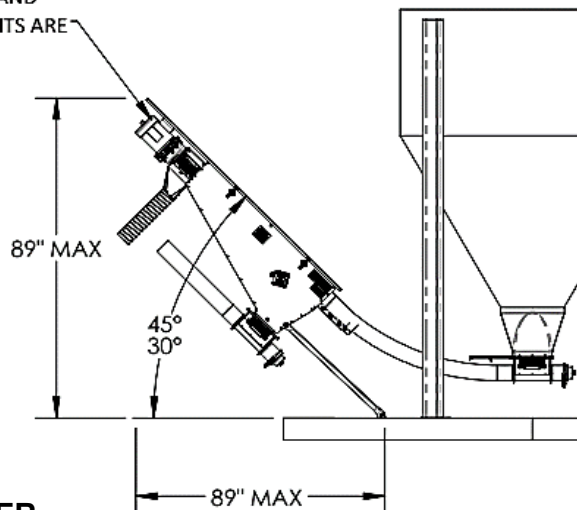

MODEL 740 (108mm) - FEED SCREENER

501530	740 Auger Feed Screener	341.0	154.7	
--------	-------------------------	-------	-------	--

MODEL 740 DROP OUTLETS & DOWNSPOUT TUBES

MODEL 740 - 4.25" (108mm) DROP OUTLETS

CATALOG #	ITEM DESCRIPTION	SHIP WEIGHT		LIST PRICE
		LBS.	KG.	
740580	4.25" All-Out Drop with Shutoff	4.9	2.2	
740483	4" ID 25' Flexible Drop Tube - Grey	23.0	10.4	
740473	4" ID 1' Clear Flexible Drop Tube - Clear (price per foot)	1.0	0.5	
740477	3"-5" Stainless Steel Hose Clamp	0.1	0.0	
740520	4" OD x 10' Long HDPE Drop Tube	5.0	2.3	
735421	4.375" ID x 6' Long Lower Drop	3.2	1.5	

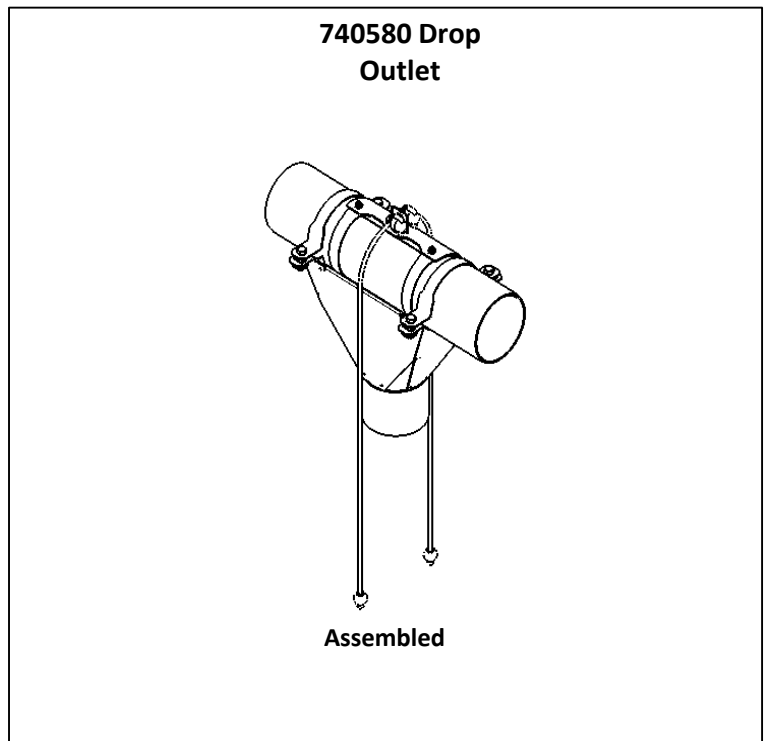
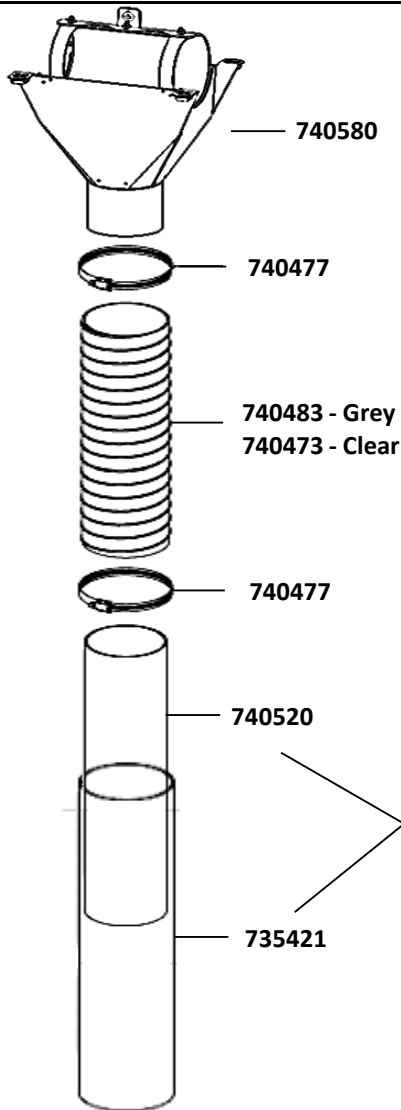



DISCHARGE HEADS

TO ORDER A COMPLETE DRIVE UNIT

DIRECT DRIVE UNIT

Order a steel (below) discharge head kit and port & driver kit from page 04-59. Also order a direct drive motor & gearbox unit from pages 04-61 thru 04-62.

STEEL DISCHARGE HEAD KITS

CATALOG #		ITEM DESCRIPTION	SHIP WEIGHT		LIST PRICE
			LBS.	KG.	
SINGLE PHASE	740521	Steel Discharge Head Kit - Basic Control - For use in 1 or 3PH applications - Shipped in two cartons: (1) 740466 Basic Steel Head (1) 730505 Control Box - Motor Relay Not Included	12.7	5.8	
	740522	Steel Discharge Head Kit - Basic Unit & Proximity Sensor - For use in 1 or 3PH applications - Shipped in three cartons: (1) 740466 Basic Steel Head (1) 730505 Control Box - Motor Relay Not Included (1) 730465 Proximity Sensor	13.1	5.9	
	740524	Steel Discharge Head Kit - Relay Control - For use in 1PH applications only - Shipped in two cartons: (1) 740466 Basic Steel Head (1) 730501 Control Box - 1PH Motor Relay included	12.8	5.8	
	740525	Steel Discharge Head Kit - Relay Control & Proximity Sensor - For use in 1PH applications only - Shipped in three cartons: (1) 740466 Basic Steel Head (1) 730501 Control Box - 1PH Motor Relay included (1) 730465 Proximity Sensor	13.2	6.0	
3-PHASE	740521	Steel Discharge Head Kit - Basic Control - For use in 1 or 3PH phase applications - Shipped in two cartons: (1) 740466 Basic Steel Head (1) 730505 Control Box - Motor Relay Not Included	12.7	5.8	
	740522	Steel Discharge Head Kit - Basic Unit & Proximity Sensor - For use in 1 or 3PH applications - Shipped in three cartons: (1) 740466 Basic Steel Head (1) 730505 Control Box - Motor Relay Not Included (1) 730465 Proximity Sensor	13.1	5.9	

*Mechanical back-up safety switch is included with all control options.
 Proximity or mechanical feed level sensing may be used with all controls.
 - See catalog section 04-59 for feed level sensing options
 Customer must provide motor relay for all basic controls*

DISCHARGE HEAD KIT COMPONENTS		SHIP WEIGHT		LIST PRICE
		LBS.	KG.	
CATALOG #	ITEM DESCRIPTION			
740466	Basic Steel Discharge Head	11.0	5.0	
730486	Discharge Head - Gasket Replacement Kit	1.3	0.6	
730505	Basic Control Box - Motor Relay Not Included - For Single or Three Phase Applications	2.3	1.0	
730501	Relay Control Box - 1PH Motor Relay Included - For Single Phase Applications Only	2.6	1.2	
730549	Proximity Sensor with Time Delay and Mount Kit - Long Delay - 90-265v, 3 sec. - 10 min. Delay	0.4	0.2	
730465	Proximity Sensor with Time Delay and Mount Kit - Long Delay - 90-265v, 3 sec. - 60 min. Delay	0.9	0.4	

PORT & DRIVER KITS FOR <u>STEEL</u> DISCHARGE HEAD FOR DIRECT DRIVE WITH 7/8" OUTPUT SHAFT		SHIP WEIGHT		LIST PRICE
		LBS.	KG.	
CATALOG #	ITEM DESCRIPTION			
740490	4.25" HM Port & Driver Kit for Direct Drive Unit - 7/8" Bore Driver	7.6	3.4	

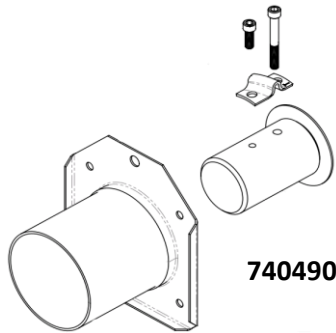

SUSPENSION COMPONENTS		SHIP WEIGHT		LIST PRICE
		LBS.	KG.	
CATALOG #	ITEM DESCRIPTION			
VEN91504C	Screw Hook 5/16" X 3 1/2" Zinc Plated	0.1	0.0	
820099	2/0 Double Loop Chain (Per Foot)	0.2	0.1	

Steel tube must be supported every 8-10 ft. Refer to manual for more information.

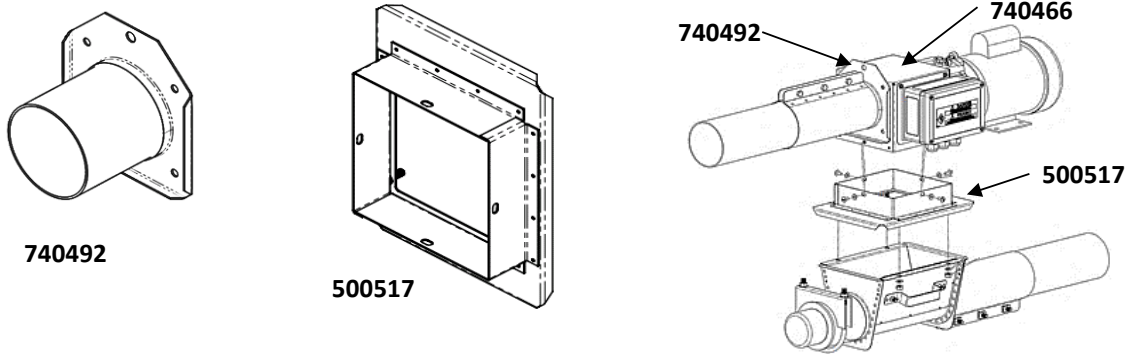

FLAG LINE & EXTENDED LENGTH SYSTEM ACCESSORIES

CATALOG #	ITEM DESCRIPTION	SHIP WEIGHT		LIST PRICE
		LBS.	KG.	
740492	Model 740 Tube and Port Plate	2.6	1.2	
740466	Model 740 Discharge Head Body	11.0	5.0	
500517	Adapter - Steel <i>Connects Steel Discharge Head or Steel Outlet Box to Lower Boot Less Slide Valve for flag line & extended length system applications.</i>	3.1	1.4	
730505	Basic Control Box with backup Switch - Motor Relay Not Included - For Single or Three Phase Applications	2.3	1.0	
730501	Relay Control Box with backup Switch - 1PH Motor Relay Included - For Single Phase Applications Only	2.6	1.2	

- Above outlet boxes used in conjunction with 500517/500590 Adapters (above) and Lower Boot Assembly Less Slide Valve (order separately from pages 04-54) to make complete flag system hopper. Hopper switches are not included.
 - Discharge head requires 1 control box with backup switch.

SWITCHES & CONTROLS

Hopper Switch Levels

460057	Hopper Level Control Switch - Proximity	5.0	2.3	
720097	Adjustable-Mechanical hopper level control 220V, 20amp, 1-3phase, 50-60hz	4.8	2.2	
451364	Hanger for Poly Hopper Switch - Galvanized	1.6	0.7	

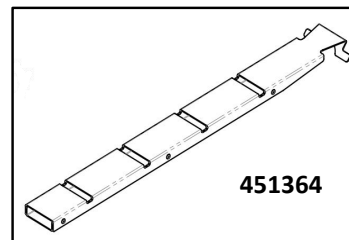
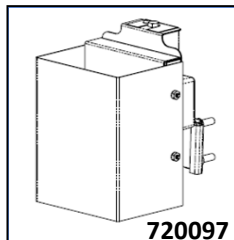
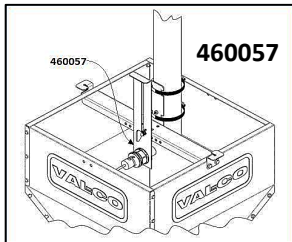

Discharge Head / Drop Tube Switch

730465	Proximity Sensor with Time Delay and Mount Kit	0.9	0.4	
735620	Downspout Feed Control Mechanical Switch FITS 3.5" I.D. DOWNSPOUT TUBE	7.7	3.5	

Boot Safety Switch

730965	Boot Safety Switch - Mechanical 110-220v, 20 amp, 1 phase, 50-60hz	1.1	0.5	
455800	Boot Safety Switch Proximity switch, 0-60 sec. delay, adj. sensitivity, 1P/220v/50-60	4.0	1.80	

Time Clock / Timer

700025	24 Hour Time Clock - 230V	3.0	1.4	
700024	24 Hour Time Clock - 115V	3.0	1.4	



DIRECT DRIVE MOTOR AND GEARBOXES

1 PHASE - 7/8" OUTPUT SHAFTS

Electrical info	115V, 50HZ, 1PH	115V, 60HZ, 1PH	230V, 50HZ, 1PH	230V, 60HZ, 1PH	OUTPUT SPEED (50/60HZ) -->	GEARBOX -->	Drive Output RPMs are approximate based on motor RPMs of 1425 @ 50Hz and 1725 @ 60 Hz. (Actual Output RPM's may vary)
	VOLTS	110	110	220			
HERTZ	50	60	50	60			
PHASE	1	1	1	1			
HP	0.50	735380	735380	735380	296/359	730089	
	0.75	735381	735381	735381			
	1.00	735527	735382	735527			
	1.50	735528	735383	735528			
	2.00			740505			
	0.50	735360	735360	735360	365/441	730124	
	0.75	735361	735361	735361			
	1.00	735342	735362	735342			
	1.50	735343	735363	735343			
	2.00			740509			

For pricing, see page 04-62
More electrical options and speeds are available upon request

DIRECT DRIVE MOTOR AND GEARBOXES

3 PHASE - 7/8" OUTPUT SHAFTS

Electrical info	230V, 60HZ, 3PH	460V, 60HZ, 3PH	190V, 50HZ, 1PH	380V, 50HZ, 3PH	OUTPUT SPEED (50/60HZ) -->	GEARBOX -->	Drive Output RPMs are approx. based on motor RPMs of 1425 @ 50Hz & 1725 @ 60Hz (Actual Output RPM's may vary)
	VOLTS	230	460	230			
HERTZ	60	60	50	50			
PHASE	3	3	3	3			
HP	0.50	735330	735330	735330	296/359	730089	
	0.75	735331	735331	735331			
	1.00	735332	735332	735332			
	1.50	735333	735333	735333			
	2.00	740506	740506	740507			
HP	0.50	735510	735510	735510	365/441	730124	
	0.75	735511	735511	735511			
	1.00	735512	735512	735512			
	1.50	735513	735513	735513			
	2.00	740510	740510	740512			

For pricing, see page 04-62
More electrical options and speeds are available upon request



DIRECT DRIVE MOTOR & GEARBOX UNITS - 7/8" OUTPUT SHAFT

CATALOG #	ITEM DESCRIPTION	SHIP WEIGHT		LIST PRICE
		LBS.	KG.	
735330	DRIVE,.50HP,296/359RPM,7/8SH,190/380&208-230/460V,50&60H,3P	33.0	15.0	
735331	DRIVE,.75HP,296/359RPM,7/8SH,190/380&208-230/460V,50&60H,3P	33.6	15.2	
735332	DRIVE,1.0HP,296/359RPM,7/8SH,190/380&208-230/460V,50&60H,3P	43.0	19.5	
735333	DRIVE,1.5HP,296/359RPM,7/8SH,190/380&208-230/460V,50&60H,3P	50.0	22.7	
735342	DRIVE,1.0HP,365RPM,7/8SH,110/220V,50H,1P	46.0	20.9	
735343	DRIVE,1.5HP,365RPM,7/8SH,110/220V,50H,1P	80.0	36.3	
735360	DRIVE,.50HP,365/441RPM,7/8SH,115/230V,50/60H,1P	50.0	22.7	
735361	DRIVE,.75HP,365/441RPM,7/8SH,115/230V,50/60H,1P	53.0	24.0	
735362	DRIVE,1.0HP,441RPM,7/8SH,115/230V,60H,1P	46.0	20.9	
735363	DRIVE,1.5HP,441RPM,7/8SH,115/230V,60H,1P	80.0	36.3	
735380	DRIVE,.50HP,296/359RPM,7/8SH,115/230V,50/60H,1P	34.0	15.4	
735381	DRIVE,.75HP,296/359RPM,7/8SH,115/230V,50/60H,1P	41.9	19.0	
735382	DRIVE,1.0HP,359RPM,7/8SH,115/230V,60H,1P	43.0	19.5	
735383	DRIVE,1.5HP,359RPM,7/8SH,115/230V,60H,1P	51.8	23.5	
735510	DRIVE,.50HP,365/441RPM,7/8SH,190/380&208-230/460V,50&60H,3P	52.0	23.6	
735511	DRIVE,.75HP,365/441RPM,7/8SH,190/380&208-230/460V,50&60H,3P	35.0	15.9	
735512	DRIVE,1.0HP,365/441RPM,7/8SH,190/380&208-230/460V,50&60H,3P	45.0	20.4	
735513	DRIVE,1.5HP,365/441RPM,7/8SH,190/380&208-230/460V,50&60H,3P	50.4	22.8	
735527	DRIVE,1.0HP,296RPM,7/8SH,110/220V,50H,1P	58.5	26.5	
735528	DRIVE,1.5HP,296RPM,7/8SH,110/220V,50H,1P	80.0	36.3	
740504	DRIVE,2HP,359RPM,7/8SH,230V,60H,1P	55.7	25.3	
740505	DRIVE,2HP,296/359RPM,7/8SH,230V,50H,1P	55.8	25.3	
740506	DRIVE,2HP,359RPM,7/8SH,230/460V,60H,3P	48.7	22.1	
740507	DRIVE,2HP,296/359RPM,7/8SH,230/460V,50/60H,3P	66.7	30.3	
740508	DRIVE,2HP,441RPM,7/8SH,230V,60H,1P	55.8	25.3	
740509	DRIVE,2HP,365/441RPM,7/8SH,230V,50H,1P	55.8	25.3	
740510	DRIVE,2HP,441RPM,7/8SH,230/460V,60H,3P	48.0	21.8	
740512	DRIVE,2HP,365/441RPM,7/8SH,230/460V,50/60H,3P	55.8	25.3	

See page 04-60 for Direct Drive Table

PINION TOOL

740517	Pinion Spacer - Field Tool	0.5	0.2	
--------	----------------------------	-----	-----	--

Toll-free: 1-800-99VALCO
Phone: (+1) 419-678-8731
Fax: (+1) 419-678-2200



Page 04-64
FLEXIBLE AUGER FILL SYSTEMS
Effective November 17, 2025

This Page Intentionally Left Blank